

ANY-RATE PRECISION CLOCK MULTIPLIER/JITTER ATTENUATOR

Description

The Si5368 is a jitter-attenuating precision clock multiplier for applications requiring sub 1 ps rms jitter performance. The Si5368 accepts four clock inputs ranging from 2 kHz to 710 MHz and generates five clock outputs ranging from 2 kHz to 945 MHz and select frequencies to 1.4 GHz. The device provides virtually any frequency translation combination across this operating range. The outputs are divided down separately from a common source. The Si5368 input clock frequency and clock multiplication ratio are programmable through an I²C or SPI interface. The Si5368 is based on Silicon Laboratories' third-generation DSPLL[®] technology, which provides any-rate frequency synthesis and jitter attenuation in a highly integrated PLL solution that eliminates the need for external VCXO and loop filter components. The DSPLL loop bandwidth is digitally programmable, providing jitter performance optimization at the application level. Operating from a single 1.8, 2.5, or 3.3 V supply, the Si5368 is ideal for providing clock multiplication and jitter attenuation in high performance timing applications.

Applications

- SONET/SDH OC-48/STM-16/OC-192/STM-64 line cards
- GbE/10GbE, 1/2/4/8/10G FC line cards
- ITU G.709 and custom FEC line cards
- Wireless basestations
- Data converter clocking
- OTN/WDM Muxponder, MSPP, ROADM line cards
- SONET/SDH + PDH clock synthesis
- Test and measurement
- Synchronous Ethernet

- Broadcast video

Features

- Generates any frequency from 2 kHz to 945 MHz and select frequencies to 1.4 GHz from an input frequency of 2 kHz to 710 MHz
- Ultra-low jitter clock outputs with jitter generation as low as 300 fs rms (50 kHz–80 MHz)
- Integrated loop filter with selectable loop bandwidth (60 Hz to 8.4 kHz)
- Meets OC-192 GR-253-CORE jitter specifications
- Four clock inputs with manual or automatically controlled hitless switching and phase build-out
- Supports holdover and freerun modes of operation
- Five clock outputs with selectable signal format (LVPECL, LVDS, CML, CMOS)
- SONET frame sync switching and regeneration
- Support for ITU G.709 and custom FEC ratios (253/226, 239/237, 255/238, 255/237, 255/236)
- LOL, LOS, FOS alarm outputs
- Digitally-controlled output phase adjust
- I²C or SPI programmable settings
- On-chip voltage regulator for 1.8 V ±5%, 2.5 V ±10%, or 3.3 V ±10% operation
- Small size: 14 x 14 mm 100-pin TQFP
- Pb-free, RoHS compliant

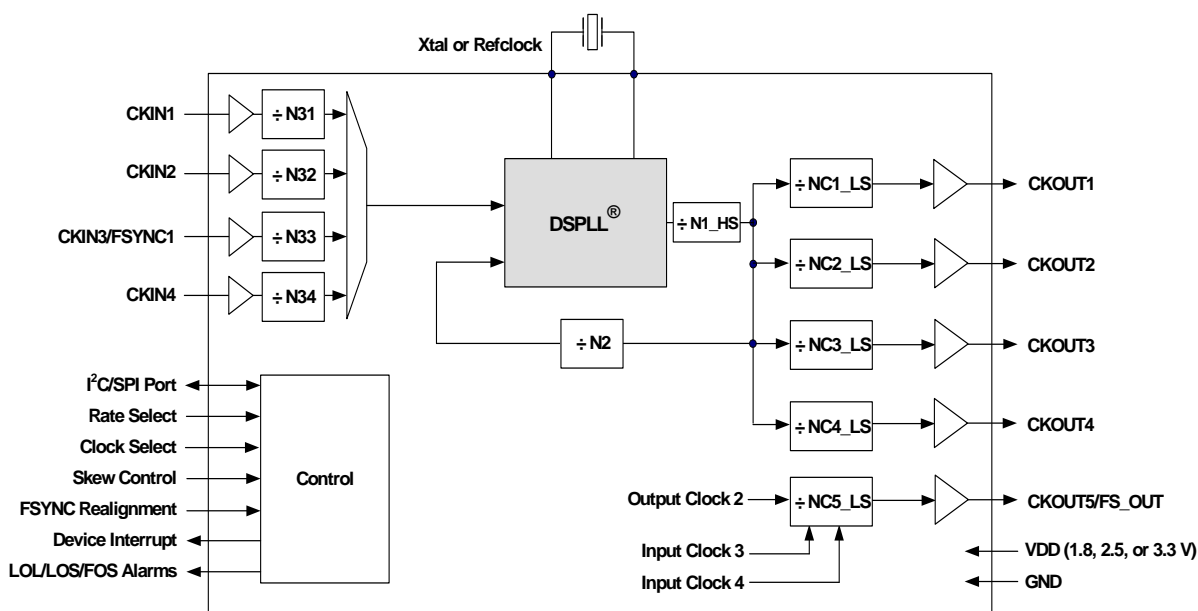

TABLE OF CONTENTS

<u>Section</u>	<u>Page</u>
1. Functional Description	9
1.1. External Reference	9
1.2. Further Documentation	9
2. Pin Descriptions: Si5368	10
3. Register Map	16
4. Register Descriptions	19
5. Ordering Guide	72
6. Package Outline: 100-Pin TQFP	73
7. Recommended PCB Layout	74
Document Change list	76
Contact Information	78

Table 1. Performance Specifications $(V_{DD} = 1.8 \pm 5\%, 2.5 \text{ V} \pm 10\%, \text{ or } 3.3 \text{ V} \pm 10\%, T_A = -40 \text{ to } 85 \text{ }^\circ\text{C})$

Parameter	Symbol	Test Condition	Min	Typ	Max	Unit
Temperature Range	T_A		-40	25	85	$^\circ\text{C}$
Supply Voltage	V_{DD}	See Note 3.	2.97	3.3	3.63	V
			2.25	2.5	2.75	V
			1.71	1.8	1.89	V
Supply Current (Supply current is independent of V_{DD})	I_{DD}	$f_{OUT} = 622.08 \text{ MHz}$ All CKOUTs enabled LVPECL format output	—	394	435	mA
		Only CKOUT1 enabled	—	253	284	mA
		$f_{OUT} = 19.44 \text{ MHz}$ All CKOUTs enabled CMOS format output	—	278	321	mA
		Only CKOUT1 enabled	—	229	261	mA
		Sleep Mode	—	165		mA
Input Clock Frequency (CKIN1, CKIN2, CKIN3, CKIN4)	CK_F	Input frequency and clock multiplication ratio determined by programming device PLL dividers. Consult Silicon Laboratories configuration software <i>DSPLLsim</i> or Any-Rate Precision Clock Family Reference Manual at www.silabs.com/timing (click on Documentation) to determine PLL divider settings for a given input frequency/clock multiplication ratio combination.	0.002	—	710	MHz
Input Clock Frequency (CKIN3, CKIN4 used as FSYNC inputs)	CK_F		0.002	—	0.512	MHz
Output Clock Frequency (CKOUT1, CKOUT2, CKOUT3, CKOUT4, CKOUT5 used as fifth high-speed output)	CK_{OF}		0.002 970 1213	— — —	945 1134 1400	MHz
CKOUT5 used as frame sync output (FS_OUT)	CK_{OF}		0.002	—	710	MHz
3-Level Input Pins						
Input Mid Current	I_{IMM}	See Note 2.	-2	—	2	μA
Input Clocks (CKIN1, CKIN2, CKIN3, CKIN4)						
Differential Voltage Swing	CK_{NDPP}		0.25	—	—	V_{PP}
Notes:						
<ol style="list-style-type: none"> For a more comprehensive listing of device specifications, please consult the Silicon Laboratories Any-Rate Precision Clock Family Reference Manual. This document can be downloaded from www.silabs.com/timing (click on Documentation). This is the amount of leakage that the 3-level input can tolerate from an external driver. See the Family Reference Manual. In most designs, an external resistor voltage divider is recommended. The LVPECL and CMOS output formats draw more current than either LVDS or CML; however, there are restrictions in the allowed output format pin settings so that the maximum power dissipation for the TQFP devices is limited when they are operated at 3.3 V. When there are four enabled LVPECL or CMOS outputs, the fifth output must be disabled. When there are five enabled outputs, there can be no more than three outputs that are either LVPECL or CMOS. 						

Table 1. Performance Specifications (Continued) $(V_{DD} = 1.8 \pm 5\%, 2.5 \text{ V} \pm 10\%, \text{ or } 3.3 \text{ V} \pm 10\%, T_A = -40 \text{ to } 85 \text{ }^\circ\text{C})$

Parameter	Symbol	Test Condition	Min	Typ	Max	Unit
Input Voltage Level Limits	CKN_{VIN}		0	—	V_{DD}	V
Common Mode Voltage	CKN_{VCM}	1.8 V $\pm 5\%$	0.9	—	1.4	V
		2.5 V $\pm 10\%$	1.0	—	1.7	V
		3.3 V $\pm 10\%$	1.1	—	1.95	V
Rise/Fall Time	CKN_{TRF}	20–80%	—	—	11	ns
Duty Cycle (Minimum Pulse Width)	CKN_{DC}	Whichever is smaller	40	—	60	%
			2	—	—	ns
Output Clocks (CKOUT1, CKOUT2, CKOUT3, CKOUT4, CKOUT5/FS_OUT)						
Common Mode	V_{OCM}	LVPECL 100 Ω load line-to-line	$V_{DD} - 1.42$	—	$V_{DD} - 1.25$	V
Differential Output Swing	V_{OD}		1.1	—	1.9	V_{DD}
Single Ended Output Swing	V_{SE}		0.5	—	0.93	V_{pp}
PLL Performance						
Jitter Generation	J_{GEN}	$f_{IN} = f_{OUT} = 622.08 \text{ MHz}$, LVPECL output format 50 kHz–80 MHz	—	300	420	fs rms
		12 kHz–20 MHz	—	300	410	fs rms
Jitter Peaking	J_{PK}	$f_{IN} = f_{OUT} = 622.08 \text{ MHz}$	—	0.05	0.1	dB
Phase Noise	CKO_{PN}	$f_{IN} = f_{OUT} = 622.08 \text{ MHz}$ 100 Hz offset	—	–65	–50	dBc/Hz
		1 kHz offset	—	–95	–87	dBc/Hz
		10 kHz offset	—	–110	–100	dBc/Hz
		100 kHz offset	—	–117	–110	dBc/Hz
		1 MHz offset	—	–130	–125	dBc/Hz
Subharmonic Noise	SP_{SUBH}	Phase Noise @ 100 kHz Offset	—	–90	–85	dBc
Spurious Noise	SP_{SPUR}	Max spur @ $n \times F_3$ ($n \geq 1, n \times F_3 < 100 \text{ MHz}$)	—	–98	–75	dBc

Notes:

- For a more comprehensive listing of device specifications, please consult the Silicon Laboratories Any-Rate Precision Clock Family Reference Manual. This document can be downloaded from www.silabs.com/timing (click on Documentation).
- This is the amount of leakage that the 3-level input can tolerate from an external driver. See the Family Reference Manual. In most designs, an external resistor voltage divider is recommended.
- The LVPECL and CMOS output formats draw more current than either LVDS or CML; however, there are restrictions in the allowed output format pin settings so that the maximum power dissipation for the TQFP devices is limited when they are operated at 3.3 V. When there are four enabled LVPECL or CMOS outputs, the fifth output must be disabled. When there are five enabled outputs, there can be no more than three outputs that are either LVPECL or CMOS.

Table 1. Performance Specifications (Continued)

($V_{DD} = 1.8 \pm 5\%$, $2.5 \text{ V} \pm 10\%$, or $3.3 \text{ V} \pm 10\%$, $T_A = -40$ to $85 \text{ }^\circ\text{C}$)

Parameter	Symbol	Test Condition	Min	Typ	Max	Unit
Package						
Thermal Resistance Junction to Ambient	θ_{JA}	Still Air	—	40	—	$^\circ\text{C}/\text{W}$
Notes:						
<ol style="list-style-type: none"> For a more comprehensive listing of device specifications, please consult the Silicon Laboratories Any-Rate Precision Clock Family Reference Manual. This document can be downloaded from www.silabs.com/timing (click on Documentation). This is the amount of leakage that the 3-level input can tolerate from an external driver. See the Family Reference Manual. In most designs, an external resistor voltage divider is recommended. The LVPECL and CMOS output formats draw more current than either LVDS or CML; however, there are restrictions in the allowed output format pin settings so that the maximum power dissipation for the TQFP devices is limited when they are operated at 3.3 V. When there are four enabled LVPECL or CMOS outputs, the fifth output must be disabled. When there are five enabled outputs, there can be no more than three outputs that are either LVPECL or CMOS. 						

Table 2. Absolute Maximum Ratings

Parameter	Symbol	Value	Unit
DC Supply Voltage	V_{DD}	-0.5 to 3.63	V
LVCMOS Input Voltage	V_{DIG}	-0.3 to ($V_{DD} + 0.3$)	V
Junction Temperature	T_{JCT}	-55 to 150	$^\circ\text{C}$
Storage Temperature Range	T_{STG}	-55 to 150	$^\circ\text{C}$
ESD HBM Tolerance (100 pF, 1.5 k Ω); All pins except CKIN+/CKIN-		2	kV
ESD MM Tolerance; All pins except CKIN+/CKIN-		200	V
ESD HBM Tolerance (100 pF, 1.5 k Ω); CKIN+/CKIN-		700	V
ESD MM Tolerance; CKIN+/CKIN-		150	V
Latch-Up Tolerance		JESD78 Compliant	
Note: Permanent device damage may occur if the Absolute Maximum Ratings are exceeded. Functional operation should be restricted to the conditions as specified in the operation sections of this data sheet. Exposure to absolute maximum rating conditions for extended periods of time may affect device reliability.			

155.52 MHz in, 622.08 MHz out

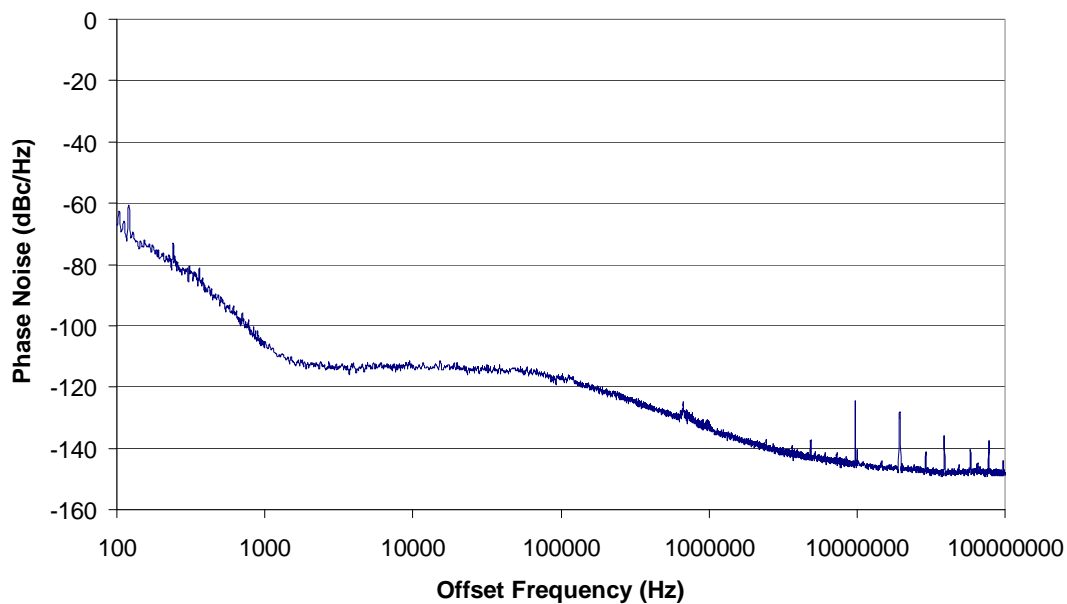

Figure 1. Typical Phase Noise Plot

Jitter Band	Jitter, RMS
Brick Wall, 100 Hz to 100 MHz	1,279 fs
SONET_OC48, 12 kHz to 20 MHz	315 fs
SONET_OC192_A, 20 kHz to 80 MHz	335 fs
SONET_OC192_B, 4 to 80 MHz	194 fs
SONET_OC192_C, 50 kHz to 80 MHz	318 fs
Brick Wall, 800 Hz to 80 MHz	343 fs

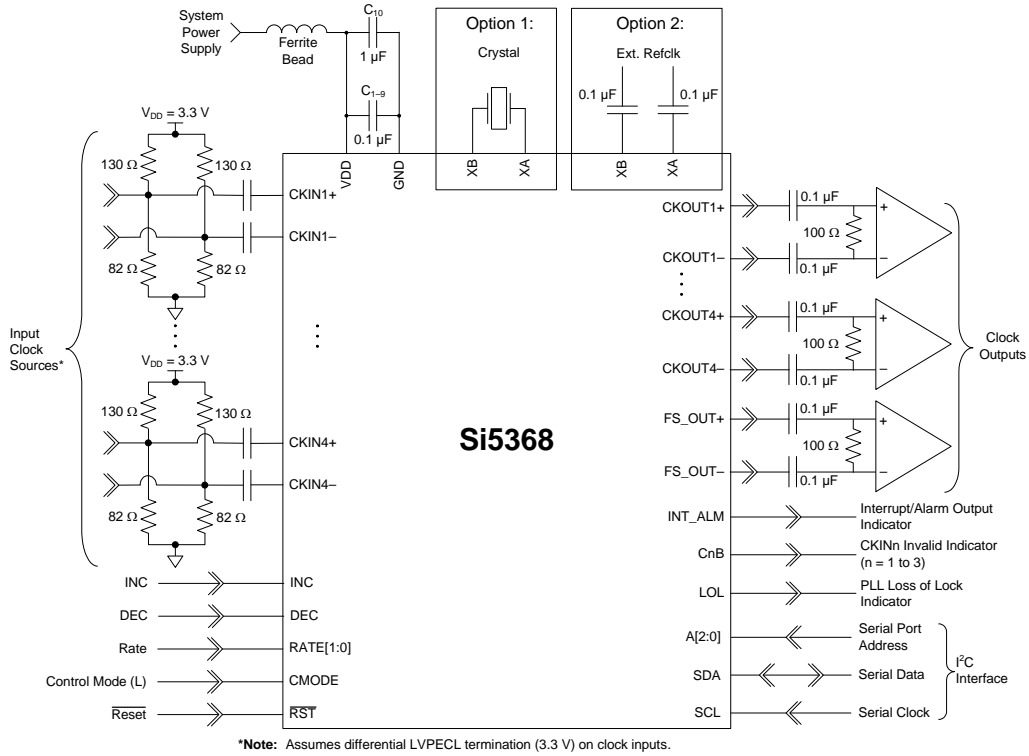

Figure 2. Si5368 Typical Application Circuit (I²C Control Mode)

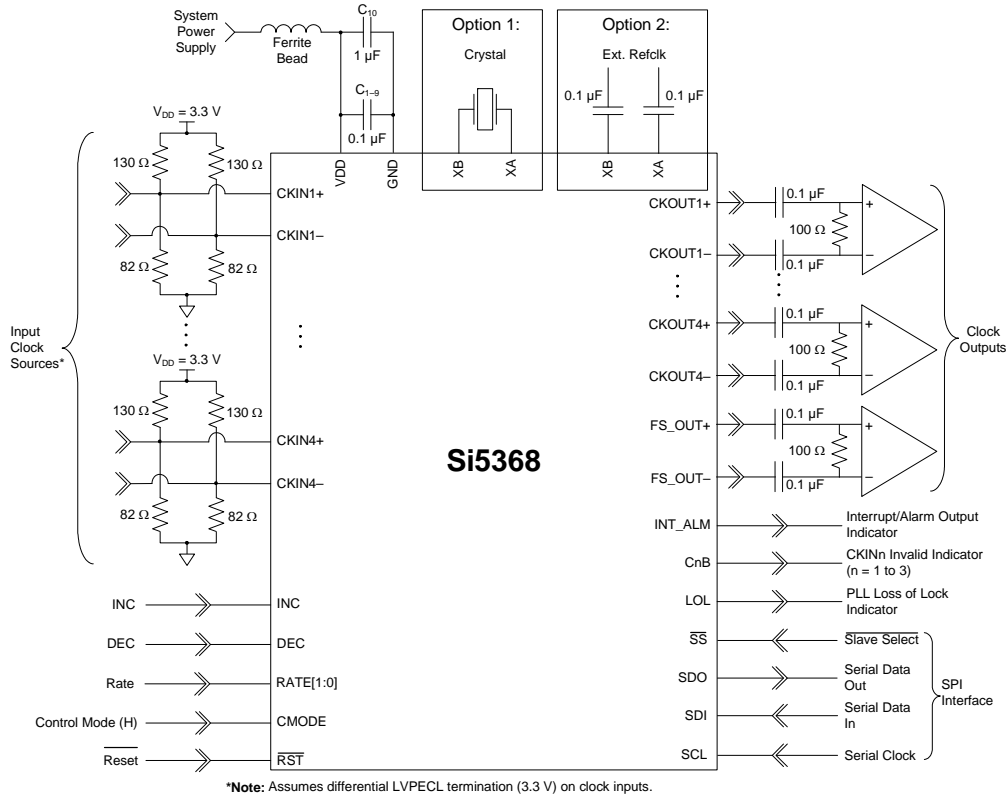

Figure 3. Si5368 Typical Application Circuit (SPI Control Mode)

1. Functional Description

The Si5368 is a jitter-attenuating precision clock multiplier for applications requiring sub 1 ps rms jitter performance. The Si5368 accepts four clock inputs ranging from 2 kHz to 710 MHz and generates five clock outputs ranging from 2 kHz to 945 MHz and select frequencies to 1.4 GHz. The device provides virtually any frequency translation combination across this operating range. Independent dividers are available for every input clock and output clock, so the Si5368 can accept input clocks at different frequencies and it can generate output clocks at different frequencies. The Si5368 input clock frequency and clock multiplication ratio are programmable through an I²C or SPI interface. Optionally, the fifth clock output can be configured as a 2 to 512 kHz SONET/SDH frame synchronization output that is phase aligned with one of the high-speed output clocks. Silicon Laboratories offers a PC-based software utility, *DSPLLsim*, that can be used to determine the optimum PLL divider settings for a given input frequency/clock multiplication ratio combination that minimizes phase noise and power consumption. This utility can be downloaded from <http://www.silabs.com/timing> (click on Documentation).

The Si5368 is based on Silicon Laboratories' 3rd-generation DSPLL[®] technology, which provides any-rate frequency synthesis and jitter attenuation in a highly integrated PLL solution that eliminates the need for external VCXO and loop filter components. The Si5368 PLL loop bandwidth is digitally programmable and supports a range from 60 Hz to 8.4 kHz. The *DSPLLsim* software utility can be used to calculate valid loop bandwidth settings for a given input clock frequency/clock multiplication ratio.

The Si5368 supports hitless switching between input clocks in compliance with GR-253-CORE and GR-1244-CORE that greatly minimizes the propagation of phase transients to the clock outputs during an input clock transition (<200 ps typ). Manual, automatic revertive and non-revertive input clock switching options are available. The Si5368 monitors the four input clocks for loss-of-signal and provides a LOS alarm when it detects missing pulses on any of the four input clocks. The device monitors the lock status of the PLL. The lock detect algorithm works by continuously monitoring the phase of the input clock in relation to the phase of the feedback clock. The Si5368 monitors the frequency of CKIN1, CKIN2, CKIN3, and CKIN4 with respect to a selected reference frequency and generates a frequency offset alarm (FOS) if the threshold is exceeded. This FOS feature is available for SONET applications in which both the monitored frequency on CKIN1, CKIN3, and CKIN4 and the reference frequency are integer multiples of 19.44 MHz. Both Stratum 3/3E and SONET Minimum Clock (SMC) FOS thresholds are supported.

The Si5368 provides a digital hold capability that allows the device to continue generation of a stable output clock when the selected input reference is lost. During digital

hold, the DSPLL generates an output frequency based on a historical average that existed a fixed amount of time before the error event occurred, eliminating the effects of phase and frequency transients that may occur immediately preceding digital hold.

Fine phase adjustment is available and is set using the FLAT register bits. The nominal range and resolution of the FLAT[14:0] latency adjustment word are: ± 110 ps and 3 ps, respectively.

The Si5368 has five differential clock outputs. The electrical format of the clock outputs is programmable to support LVPECL, LVDS, CML, or CMOS loads. If not required, unused clock outputs can be powered down to minimize power consumption. The phase difference between the selected input clock and the output clocks is adjustable in 200 ps increments for system skew control. In addition, the phase of one output clock may be adjusted in relation to the phase of the other output clock. The resolution varies from 800 ps to 2.2 ns depending on the PLL divider settings. Consult the *DSPLLsim* configuration software to determine the phase offset resolution for a given input clock/clock multiplication ratio combination. For system-level debugging, a bypass mode is available which drives the output clock directly from the input clock, bypassing the internal DSPLL. The device is powered by a single 1.8 or 2.5 V supply.

1.1. External Reference

An external, 38.88 MHz clock or a low-cost 114.285 MHz 3rd overtone crystal is used as part of a fixed-frequency oscillator within the DSPLL. This external reference is required for the device to operate. Silicon Laboratories recommends using a high-quality crystal. Specific recommendations may be found in the Family Reference Manual. An external clock from a high-quality OCXO or TCXO can also be used as a reference for the device.

In digital hold, the DSPLL remains locked to this external reference. Any changes in the frequency of this reference when the DSPLL is in digital hold, will be tracked by the output of the device. Note that crystals can have temperature sensitivities.

1.2. Further Documentation

Consult the Silicon Laboratories Any-Rate Precision Clock Family Reference Manual (FRM) for detailed information about the Si5368. Additional design support is available from Silicon Laboratories through your distributor.

Silicon Laboratories has developed a PC-based software utility called *DSPLLsim* to simplify device configuration, including frequency planning and loop bandwidth selection. The FRM and this utility can be downloaded from <http://www.silabs.com/timing>; click on Documentation.

Si5368

2. Pin Descriptions: Si5368

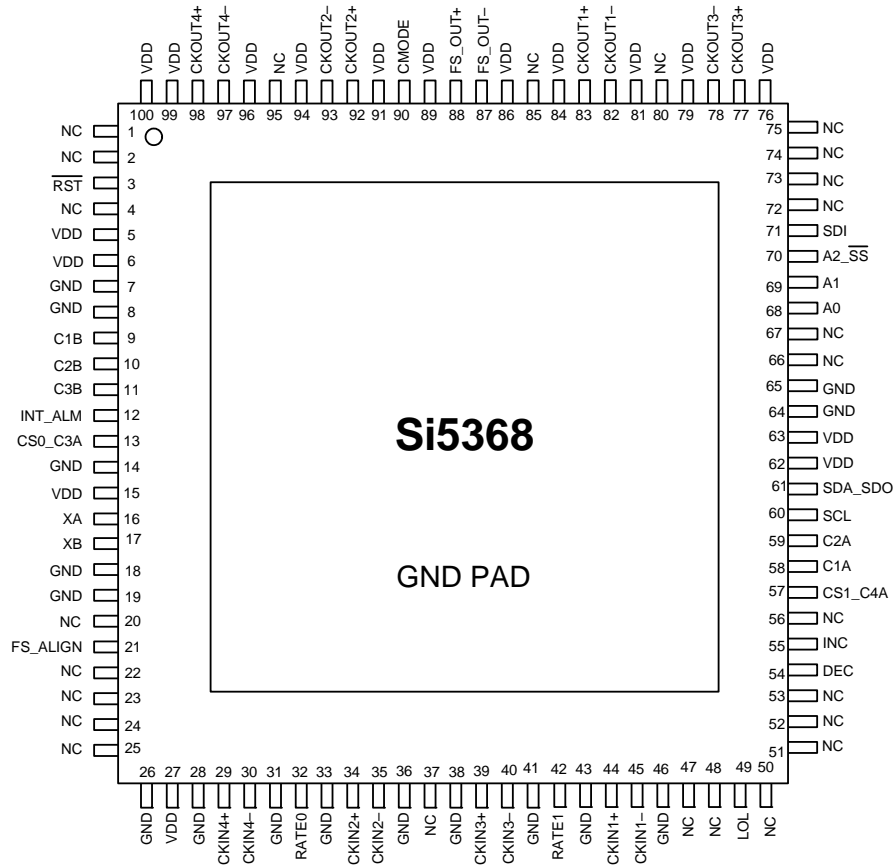

Table 3. Si5368 Pin Descriptions

Pin #	Pin Name	I/O	Signal Level	Description
1, 2, 4, 20, 22, 23, 24, 25, 37, 47, 48, 50, 51, 52, 53, 56, 66, 67, 72, 73, 74, 75, 80, 85, 95	NC			No Connect. These pins must be left unconnected for normal operation.
3	$\overline{\text{RST}}$	I	LVC MOS	External Reset. Active low input that performs external hardware reset of device. Resets all internal logic to a known state and forces the device registers to their default value. Clock outputs are disabled during reset. The part must be programmed after a reset or power-on to get a clock output. See Family Reference Manual for details. This pin has a weak pull-up.
Note: Internal register names are indicated by underlined italics, e.g. <i>INT PIN</i> . See Si5368 Register Map.				

Table 3. Si5368 Pin Descriptions (Continued)

Pin #	Pin Name	I/O	Signal Level	Description																				
5, 6, 15, 27, 62, 63, 76, 79, 81, 84, 86, 89, 91, 94, 96, 99, 100	V _{DD}	V _{DD}	Supply	V_{DD}. The device operates from a 1.8, 2.5, or 3.3 V supply. Bypass capacitors should be associated with the following V _{DD} pins: <table border="1"> <thead> <tr> <th>Pins</th> <th>Bypass Cap</th> </tr> </thead> <tbody> <tr> <td>5, 6</td> <td>0.1 μF</td> </tr> <tr> <td>15</td> <td>0.1 μF</td> </tr> <tr> <td>27</td> <td>0.1 μF</td> </tr> <tr> <td>62, 63</td> <td>0.1 μF</td> </tr> <tr> <td>76, 79</td> <td>1.0 μF</td> </tr> <tr> <td>81, 84</td> <td>0.1 μF</td> </tr> <tr> <td>86, 89</td> <td>0.1 μF</td> </tr> <tr> <td>91, 94</td> <td>0.1 μF</td> </tr> <tr> <td>96, 99, 100</td> <td>0.1 μF</td> </tr> </tbody> </table>	Pins	Bypass Cap	5, 6	0.1 μF	15	0.1 μF	27	0.1 μF	62, 63	0.1 μF	76, 79	1.0 μF	81, 84	0.1 μF	86, 89	0.1 μF	91, 94	0.1 μF	96, 99, 100	0.1 μF
Pins	Bypass Cap																							
5, 6	0.1 μF																							
15	0.1 μF																							
27	0.1 μF																							
62, 63	0.1 μF																							
76, 79	1.0 μF																							
81, 84	0.1 μF																							
86, 89	0.1 μF																							
91, 94	0.1 μF																							
96, 99, 100	0.1 μF																							
7, 8, 14, 18, 19, 26, 28, 31, 33, 36, 38, 41, 43, 46, 64, 65	GND	GND	Supply	Ground. This pin must be connected to system ground. Minimize the ground path impedance for optimal performance.																				
9	C1B	O	LVC MOS	CKIN1 Invalid Indicator. This pin performs the <u>CK1_BAD</u> function if <u>CK1_BAD_PIN</u> = 1 and is tristated if <u>CK1_BAD_PIN</u> = 0. Active polarity is controlled by <u>CK_BAD_POL</u> . 0 = No alarm on CKIN1. 1 = Alarm on CKIN1.																				
10	C2B	O	LVC MOS	CKIN2 Invalid Indicator. This pin performs the <u>CK2_BAD</u> function if <u>CK2_BAD_PIN</u> = 1 and is tristated if <u>CK2_BAD_PIN</u> = 0. Active polarity is controlled by <u>CK_BAD_POL</u> . 0 = No alarm on CKIN2. 1 = Alarm on CKIN2.																				
11	C3B	O	LVC MOS	CKIN3 Invalid Indicator. This pin performs the <u>CK3_BAD</u> function if <u>CK3_BAD_PIN</u> = 1 and is tristated if <u>CK3_BAD_PIN</u> = 0. Active polarity is controlled by <u>CK_BAD_POL</u> . 0 = No alarm on CKIN3. 1 = Alarm on CKIN3.																				
12	INT_ALM	O	LVC MOS	Interrupt/Alarm Output Indicator. This pin functions as a maskable interrupt output with active polarity controlled by the <u>INT_POL</u> register bit. The INT output function can be turned off by setting <u>INT_PIN</u> = 0. If the ALRMOUT function is desired instead on this pin, set <u>ALRMOUT_PIN</u> = 1 and <u>INT_PIN</u> = 0. 0 = <u>ALRMOUT</u> not active. 1 = <u>ALRMOUT</u> active. The active polarity is controlled by <u>CK_BAD_POL</u> . If no function is selected, the pin tristates.																				

Note: Internal register names are indicated by underlined italics, e.g. INT_PIN. See Si5368 Register Map.

Table 3. Si5368 Pin Descriptions (Continued)

Pin #	Pin Name	I/O	Signal Level	Description										
13 57	CS0_C3A CS1_C4A	I/O	LVC MOS	<p>Input Clock Select/CKIN3 or CKIN4 Active Clock Indicator. Input: If manual clock selection is chosen, and if <u>CKSEL PIN</u> = 1, the CKSEL pins control clock selection and the <u>CKSEL REG</u> bits are ignored.</p> <table border="1"> <thead> <tr> <th>CS[1:0]</th> <th>Active Input Clock</th> </tr> </thead> <tbody> <tr> <td>00</td> <td>CKIN1</td> </tr> <tr> <td>01</td> <td>CKIN2</td> </tr> <tr> <td>10</td> <td>CKIN3</td> </tr> <tr> <td>11</td> <td>CKIN4</td> </tr> </tbody> </table> <p>If <u>CKSEL PIN</u> = 0, the <u>CKSEL REG</u> register bits control this function and these inputs tristate. If configured as inputs, these pins must not float. Output: If auto clock selection is enabled, then they serve as the CKIN_n active clock indicator. 0 = CKIN3 (CKIN4) is not the active input clock 1 = CKIN3 (CKIN4) is currently the active input to the PLL The <u>CKn ACTV REG</u> bit always reflects the active clock status for CKIN_n. If <u>CKn ACTV PIN</u> = 1, this status will also be reflected on the CnA pin with active polarity controlled by the <u>CK ACTV POL</u> bit. If <u>CKn ACTV PIN</u> = 0, this output tristates.</p>	CS[1:0]	Active Input Clock	00	CKIN1	01	CKIN2	10	CKIN3	11	CKIN4
CS[1:0]	Active Input Clock													
00	CKIN1													
01	CKIN2													
10	CKIN3													
11	CKIN4													
16 17	XA XB	I	ANALOG	<p>External Crystal or Reference Clock. External crystal should be connected to these pins to use internal oscillator based reference. Refer to Family Reference Manual for interfacing to an external reference. External reference must be from a high-quality clock source (TCXO, OCXO). Frequency of crystal or external clock is set by the RATE pins.</p>										
21	FS_ALIGN	I	LVC MOS	<p>FSYNC Alignment Control. If <u>FSYNC ALIGN PIN</u> = 1 and <u>CK CONFIG</u> = 1, a logic high on this pin causes the FS_OUT phase to be realigned to the rising edge of the currently active input sync (CKIN_3 or CKIN_4). If <u>FSYNC ALIGN PIN</u> = 0, this pin is ignored and the <u>FSYNC ALIGN REG</u> bit performs this function. 0 = No realignment. 1 = Realign. This pin has a weak pull-down.</p>										
29 30	CKIN4+ CKIN4-	I	MULTI	<p>Clock Input 4. Differential clock input. This input can also be driven with a single-ended signal. CKIN4 serves as the frame sync input associated with the CKIN2 clock when <u>CK CONFIG REG</u> = 1.</p>										
32 42	RATE0 RATE1	I	3-Level	<p>External Crystal or Reference Clock Rate. Three level inputs that select the type and rate of external crystal or reference clock to be applied to the XA/XB port. Refer to the Family Reference Manual for settings. These pins have both a weak pull-up and a weak pull-down; they default to M.</p>										
<p>Note: Internal register names are indicated by underlined italics, e.g. <u>INT PIN</u>. See Si5368 Register Map.</p>														

Table 3. Si5368 Pin Descriptions (Continued)

Pin #	Pin Name	I/O	Signal Level	Description
34 35	CKIN2+ CKIN2-	I	MULTI	Clock Input 2. Differential input clock. This input can also be driven with a single-ended signal.
39 40	CKIN3+ CKIN3-	I	MULTI	Clock Input 3. Differential clock input. This input can also be driven with a single-ended signal. CKIN3 serves as the frame sync input associated with the CKIN1 clock when <u>CK_CONFIG_REG</u> = 1.
44 45	CKIN1+ CKIN1-	I	MULTI	Clock Input 1. Differential clock input. This input can also be driven with a single-ended signal.
49	LOL	O	LVC MOS	PLL Loss of Lock Indicator. This pin functions as the active high PLL loss of lock indicator if the <u>LOL_PIN</u> register bit is set to one. 0 = PLL locked. 1 = PLL unlocked. If LOL_PIN = 0, this pin will tristate. Active polarity is controlled by the <u>LOL_POL</u> bit. The PLL lock status will always be reflected in the <u>LOL_INT</u> read only register bit.
54	DEC	I	LVC MOS	Coarse Latency Decrement. A pulse on this pin decreases the input to output device latency by 1/fOSC (approximately 200 ps). Detailed operations and timing characteristics for this pin may be found in the Any-Rate Precision Clock Family Reference Manual. There is no limit on the range of latency adjustment by this method. Pin control is enabled by setting <u>INCDEC_PIN</u> = 1 (default). If <u>INCDEC_PIN</u> = 0, this pin is ignored and coarse output latency is controlled via the CLAT register. If both INC and DEC are tied high, phase buildout is disabled and the device maintains a fixed-phase relationship between the selected input clock and the output clock during an input clock switch. Detailed operations and timing characteristics for these pins may be found in the Any-Rate Precision Clock Family Reference Manual. This pin has a weak pull-down.

Note: Internal register names are indicated by underlined italics, e.g. INT_PIN. See Si5368 Register Map.

Table 3. Si5368 Pin Descriptions (Continued)

Pin #	Pin Name	I/O	Signal Level	Description
55	INC	I	LVC MOS	<p>Coarse Latency Increment. A pulse on this pin increases the input to output device latency by 1/fOSC (approximately 200 ps). Detailed operations, restrictions, and timing characteristics for this pin may be found in the Any-Rate Precision Clock Family Reference Manual. There is no limit on the range of latency adjustment by this method. Pin control is enabled by setting <u>INCDEC PIN</u> = 1 (default).</p> <p>Note: INC does not increase latency if NI_HS = 4. If <u>INCDEC PIN</u> = 0, this pin is ignored and coarse output latency is controlled via the <u>CLAT</u> register. If both INC and DEC are tied high, phase buildout is disabled and the device maintains a fixed-phase relationship between the selected input clock and the output clock during an input clock switch. Detailed operations and timing characteristics for these pins may be found in the Any-Rate Precision Clock Family Reference Manual. This pin has a weak pull-down.</p>
58	C1A	O	LVC MOS	<p>CKIN1 Active Clock Indicator. This pin serves as the CKIN1 active clock indicator. The <u>CK1 ACTV REG</u> bit always reflects the active clock status for CKIN1. If <u>CK1 ACTV PIN</u> = 1, this status will also be reflected on the C1A pin with active polarity controlled by the <u>CK ACTV POL</u> bit. If <u>CK1 ACTV PIN</u> = 0, this output tristates.</p>
59	C2A	O	LVC MOS	<p>CKIN2 Active Clock Indicator. This pin serves as the CKIN2 active clock indicator. The <u>CK2 ACTV REG</u> bit always reflects the active clock status for CKIN_2. If <u>CK2 ACTV PIN</u> = 1, this status will also be reflected on the C2A pin with active polarity controlled by the <u>CK ACTV POL</u> bit. If <u>CK2 ACTV PIN</u> = 0, this output tristates.</p>
60	SCL	I	LVC MOS	<p>Serial Clock. This pin functions as the serial port clock input for both SPI and I²C modes. This pin has a weak pull-down.</p>
61	SDA_SDO	I/O	LVC MOS	<p>Serial Data. In I²C microprocessor control mode (CMODE = 0), this pin functions as the bidirectional serial data port. In SPI microprocessor control mode (CMODE = 1), this pin functions as the serial data output.</p>
68 69	A0 A1	I	LVC MOS	<p>Serial Port Address. In I²C microprocessor control mode (CMODE = 0), these pins function as hardware controlled address bits. The I²C address is 1101 [A2] [A1] [A0]. In SPI microprocessor control mode (CMODE = 1), these pins are ignored. This pin has a weak pull-down.</p>
70	A2_SS	I	LVC MOS	<p>Serial Port Address/Slave Select. In I²C microprocessor control mode (CMODE = 0), this pin functions as a hardware controlled address bit [A2]. In SPI microprocessor control mode (CMODE = 1), this pin functions as the slave select input. This pin has a weak pull-down.</p>
<p>Note: Internal register names are indicated by underlined italics, e.g. <u>INT PIN</u>. See Si5368 Register Map.</p>				

Table 3. Si5368 Pin Descriptions (Continued)

Pin #	Pin Name	I/O	Signal Level	Description
71	SDI	I	LVC MOS	Serial Data In. In SPI microprocessor control mode (CMODE = 1), this pin functions as the serial data input. In I ² C microprocessor control mode (CMODE = 0), this pin is ignored. This pin has a weak pull-down.
77 78	CKOUT3+ CKOUT3-	O	MULTI	Clock Output 3. Differential clock output. Output signal format is selected by <u>SFOUT3_REG</u> register bits. Output is differential for LVPECL, LVDS, and CML compatible modes. For CMOS format, both output pins drive identical single-ended clock outputs.
82 83	CKOUT1- CKOUT1+	O	MULTI	Clock Output 1. Differential clock output. Output signal format is selected by <u>SFOUT1_REG</u> register bits. Output is differential for LVPECL, LVDS, and CML compatible modes. For CMOS format, both output pins drive identical single-ended clock outputs.
87 88	FS_OUT- FS_OUT+	O	MULTI	Frame Sync Output. Differential frame sync output or fifth high-speed clock output. Output signal format is selected by <u>SFOUT_FSYNC_REG</u> register bits. Output is differential for LVPECL, LVDS, and CML compatible modes. For CMOS format, both output pins drive identical single-ended clock outputs. Duty cycle and active polarity are controlled by <u>FSYNC_PW</u> and <u>FSYNC_POL</u> bits, respectively. Detailed operations and timing characteristics for these pins may be found in the Any-Rate Precision Clock Family Reference Manual.
90	CMODE	I	LVC MOS	Control Mode. Selects I ² C or SPI control mode for the device. 0 = I ² C Control Mode. 1 = SPI Control Mode. This pin must be tied high or low.
92 93	CKOUT2+ CKOUT2-	O	MULTI	Clock Output 2. Differential clock output. Output signal format is selected by <u>SFOUT2_REG</u> register bits. Output is differential for LVPECL, LVDS, and CML compatible modes. For CMOS format, both output pins drive identical single-ended clock outputs.
97 98	CKOUT4- CKOUT4+	O	MULTI	Clock Output 4. Differential clock output. Output signal format is selected by <u>SFOUT4_REG</u> register bits. Output is differential for LVPECL, LVDS, and CML compatible modes. For CMOS format, both output pins drive identical single-ended clock outputs.
GND PAD	GND PAD	GND	Supply	Ground Pad. The ground pad must provide a low thermal and electrical impedance to a ground plane.

Note: Internal register names are indicated by underlined italics, e.g. INT_PIN. See Si5368 Register Map.

3. Register Map

All register bits that are not defined in this map should always be written with the specified Reset Values. The writing to these bits of values other than the specified Reset Values may result in undefined device behavior. Registers not listed, such as Register 64, should never be written to.

Register	D7	D6	D5	D4	D3	D2	D1	D0
0		FREE_RUN	CKOUT_ALWAYS_ON		CK_CONFIG_REG		BYPASS_REG	
1	CK_PRIOR4 [1:0]		CK_PRIOR3 [1:0]		CK_PRIOR2 [1:0]		CK_PRIOR1 [1:0]	
2	BWSEL_REG [3:0]							
3	CKSEL_REG [1:0]		DHOLD	SQ_ICAL				
4	AUTOSEL_REG [1:0]			HIST_DEL [4:0]				
5	ICMOS [1:0]		SFOUT2_REG [2:0]			SFOUT1_REG [2:0]		
6		SLEEP	SFOUT4_REG [2:0]			SFOUT3_REG [2:0]		
7			SFOUT5_REG [2:0]			FOSREFSEL [2:0]		
8	HLOG_4 [1:0]		HLOG_3 [1:0]		HLOG_2 [1:0]		HLOG_1 [1:0]	
9	HIST_AVG [4:0]						HLOG_5 [1:0]	
10			DSBL5_REG		DSBL4_REG	DSBL3_REG	DSBL2_REG	DSBL1_REG
11	ALIGN_THR [2:0]				PD_CK4	PD_CK3	PD_CK2	PD_CK1
12	FPW_VALID	FSYNC_ALIGN_REG	FSYNC_ALIGN_MODE	FSYNC_SWTCH_REG	FSKEW_VALID	FSYNC_SKEW [16:16]	FSYNC_PW [9:8]	
13	FSYNC_PW [7:0]							
14	FSYNC_SKEW [15:8]							
15	FSYNC_SKEW [7:0]							
16	CLAT [7:0]							
17	FLAT_VALID	FLAT [14:8]						
18	FLAT [7:0]							
19	FOS_EN	FOS_THR [1:0]		VALTIME [1:0]		LOCKT [2:0]		
20			ALRMOUT_PIN	CK3_BAD_PIN	CK2_BAD_PIN	CK1_BAD_PIN	LOL_PIN	INT_PIN
21	INCDEC_PIN		FSYNC_ALIGN_PIN	CK4_ACTV_PIN	CK3_ACTV_PIN	CK2_ACTV_PIN	CK1_ACTV_PIN	CKSEL_PIN
22	FSYNC_ALIGN_POL	FSYNC_POL		FSYNCOUT_POL	CK_ACTV_POL	CK_BAD_POL	LOL_POL	INT_POL

Register	D7	D6	D5	D4	D3	D2	D1	D0
23				LOS4_MSK	LOS3_MSK	LOS2_MSK	LOS1_MSK	LOSX_MSK
24			ALIGN_MSK	FOS4_MSK	FOS3_MSK	FOS2_MSK	FOS1_MSK	LOL_MSK
25	N1_HS [2:0]				NC1_LS [19:16]			
26	NC1_LS [15:8]							
27	NC1_LS [7:0]							
28					NC2_LS [19:16]			
29	NC2_LS [15:8]							
30	NC2_LS [7:0]							
31					NC3_LS [19:16]			
32	NC3_LS [15:8]							
33	NC3_LS [7:0]							
34					NC4_LS [19:16]			
35	NC4_LS [15:8]							
36	NC4_LS [7:0]							
37					NC5_LS [19:16]			
38	NC5_LS [15:8]							
39	NC5_LS [7:0]							
40	N2_HS [2:0]				N2_LS [19:16]			
41	N2_LS [15:8]							
42	N2_LS [7:0]							
43						N31_ [18:16]		
44	N31_ [15:8]							
45	N31_ [7:0]							
46						N32_ [18:16]		
47	N31_ [15:8]							
48	N32_ [7:0]							
49						N33_ [18:16]		
50	N33_ [15:8]							
51	N33_ [7:0]							
52						N34_ [18:16]		
53	N34_ [15:8]							

Si5368

Register	D7	D6	D5	D4	D3	D2	D1	D0
54	N34_[7:0]							
55			CLKIN2RATE_[2:0]			CLKIN1RATE[2:0]		
56			CLKIN4RATE_[2:0]			CLKIN3RATE[2:0]		
128					CK4_ACTV_ REG	CK3_ACTV_ REG	CK2_ACTV_ REG	CK1_ACTV_ REG
129				LOS4_INT	LOS3_INT	LOS2_INT	LOS1_INT	LOSX_INT
130	CLAT- PROGRESS	DIGHOLD- VALID	ALIGN_INT	FOS4_INT	FOS3_INT	FOS2_INT	FOS1_INT	LOL_INT
131				LOS4_FLG	LOS3_FLG	LOS2_FLG	LOS1_FLG	LOSX_FLG
132		ALIGN_FLG	FOS4_FLG	FOS3_FLG	FOS2_FLG	FOS1_FLG	LOL_FLG	AIGN_ERR [8:8]
133	ALIGN_ERR [7:0]							
134	PARTNUM_RO [11:4]							
135	PARTNUM_RO [3:0]				REVID_RO [3:0]			
136	RST_REG	ICAL					GRADE_RO [1:0]	
138					LOS4_EN [1:1]	LOS3_EN [1:1]	LOS2_EN [1:1]	LOS1_EN [1:1]
139	LOS4_EN [0:0]	LOS3_EN [0:0]	LOS2_EN [0:0]	LOS1_EN [0:0]	FOS4_EN	FOS3_EN	FOS2_EN	FOS1_EN
140	INDEPENDENTSKEW1 [7:0]							
141	INDEPENDENTSKEW2 [7:0]							
142	INDEPENDENTSKEW3 [7:0]							
143	INDEPENDENTSKEW4 [7:0]							
144	INDEPENDENTSKEW5 [7:0]							
185	NVM_REVID [7:0]							

4. Register Descriptions

Register 0.

Bit	D7	D6	D5	D4	D3	D2	D1	D0
Name		FREE_ RUN	CKOUT_ ALWAYS_ ON		CK_ CONFIG_ REG		BYPASS_ REG	
Type	R	R/W	R/W	R	R/W	R	R/W	R

Reset value = 0001 0100

Bit	Name	Function
7	Reserved	Reserved.
6	FREE_RUN	Free Run. Internal to the device, route XA/XB to CKIN2. This allows the device to lock to its external reference. 0: Disable Free Run 1: Enable
5	CKOUT_ ALWAYS_ON	CKOUT Always On. This will bypass the SQ_ICAL function. Output will be available even if SQ_ICAL is on and ICAL is not complete or successful. See Table 4. 0: Squelch output until part is calibrated (ICAL). 1: Provide an output. Note: The frequency may be significantly off until the part is calibrated.
4	Reserved	Reserved.
3	CK_CONFIG_ REG	CK_CONFIG_REG. This bit controls the input clock configuration for either normal CLKIN function or FSYNC operation. Whenever CK_CONFIG_REG = 1, FSYNC_ALIGN_MODE must not be set to 1. 0: CKIN_1, 2, 3, 4 inputs do not have a synchronized relationship. CLKOUT5 is an independent output. There is no FSYNCOUT. 1: CKIN_1, 3 and CKIN_2, 4 Clock/FSYNC pairs. CKOUT5 is configured as the FSYNC output.
2	Reserved	Reserved.
1	BYPASS_ REG	Bypass Register. This bit enables or disables the PLL bypass mode. Use is only valid when the part is in digital hold or before the first ICAL. 0: Normal operation 1: Bypass mode. Selected input clock is connected to CKOUT buffers, bypassing PLL.
0	Reserved	Reserved.

Register 1.

Bit	D7	D6	D5	D4	D3	D2	D1	D0
Name	CK_PRIOR4 [1:0]		CK_PRIOR3 [1:0]		CK_PRIOR2 [1:0]		CK_PRIOR1 [1:0]	
Type	R/W	R/W	R/W	R/W	R/W	R/W	R/W	R/W

Reset value = 1110 0100

Bit	Name	Function
7:6	CK_PRIOR4 [1:0]	Selects which of the input clocks will be 4th priority in the autoselection state machine. 00: CKIN0 is 4th priority 01: CKIN1 is 4th priority 10: CKIN2 is 4th priority 11: CKIN3 is 4th priority
5:4	CK_PRIOR3 [1:0]	Selects which of the input clocks will be 3rd priority in the autoselection state machine. 00: CKIN0 is 3rd priority 01: CKIN1 is 3rd priority 10: CKIN2 is 3rd priority 11: CKIN3 is 3rd priority
3:2	CK_PRIOR2 [1:0]	CK_PRIOR 2. Selects which of the input clocks will be 2nd priority in the autoselection state machine. 00: CKIN1 is 2nd priority 01: CKIN2 is 2nd priority 10: CKIN3 is 2nd priority 11: CKIN4 is 2nd priority
1:0	CK_PRIOR1 [1:0]	CK_PRIOR 1. Selects which of the input clocks will be 1st priority in the autoselection state machine. 00: CKIN0 is 1st priority 01: CKIN1 is 1st priority 10: CKIN2 is 1st priority 11: CKIN3 is 1st priority

Register 2.

Bit	D7	D6	D5	D4	D3	D2	D1	D0
Name	BWSEL_REG [3:0]				Reserved			
Type	R/W				R			

Reset value = 0100 0010

Bit	Name	Function
7:4	BWSEL_REG [3:0]	BWSEL_REG. Selects nominal f3dB bandwidth for PLL. See the DSPLLsim for settings. After BWSEL_REG is written with a new value, an ICAL is required for the change to take effect.
3:0	Reserved	Reserved.

Register 3.

Bit	D7	D6	D5	D4	D3	D2	D1	D0
Name	CKSEL_REG [1:0]		DHOLD	SQ_ICAL	Reserved			
Type	R/W		R/W	R/W	R			

Reset value = 0000 0101

Bit	Name	Function
7:6	CKSEL_REG [1:0]	CKSEL_REG. If the device is operating in manual register-based clock selection mode (AUTOSEL_REG = 00), and CKSEL_PIN = 0, then these bits select which input clock will be the active input clock. If CKSEL_PIN = 1, the CKSEL[1:0] input pins continue to control clock selection and CKSEL_REG is of no consequence. 00: CKIN_1 selected. 01: CKIN_2 selected. 10: CKIN_3 selected. 11: CKIN_4 selected.
5	DHOLD	DHOLD. Forces the part into digital hold. This bit overrides all other manual and automatic clock selection controls. 0: Normal operation. 1: Force digital hold mode. Overrides all other settings and ignores the quality of all of the input clocks.

Si5368

4	SQ_ICAL	SQ_ICAL. This bit determines if the output clocks will remain enabled or be squelched (disabled) during an internal calibration. See Table 4. 0: Output clocks enabled during ICAL. 1: Output clocks disabled during ICAL.
3:0	Reserved	Reserved.

Register 4.

Bit	D7	D6	D5	D4	D3	D2	D1	D0
Name	AUTOSEL_REG [1:0]		Reserved	HIST_DEL [4:0]				
Type	R/W		R	R/W				

Reset value = 0001 0010

Bit	Name	Function
7:6	AUTOSEL_REG [1:0]	AUTOSEL_REG [1:0]. Selects method of input clock selection to be used. 00: Manual (either register or pin controlled. See CKSEL_PIN). 01: Automatic Non-Revertive 10: Automatic Revertive 11: Reserved
5	Reserved	Reserved.
4:0	HIST_DEL [4:0]	HIST_DEL [4:0]. Selects amount of delay to be used in generating the history information MHIST, the value of M used during Digital Hold.

Register 5.

Bit	D7	D6	D5	D4	D3	D2	D1	D0
Name	ICMOS [1:0]		SFOUT2_REG [2:0]			SFOUT1_REG [2:0]		
Type	R/W		R/W			R/W		

Reset value = 1110 1101

Bit	Name	Function
7:6	ICMOS [1:0]	<p>ICMOS [1:0]. When the output buffer is set to CMOS mode, these bits determine the output buffer drive strength. The first number below refers to 3.3 V operation; the second to 1.8 V operation. These values assume CKOUT+ is tied to CKOUT-.</p> <p>00: 8mA/2mA 01: 16mA/4mA 10: 24mA/6mA 11: 32mA (3.3 V operation)/8mA (1.8 V operation)</p>
5:3	SFOUT2_REG [2:0]	<p>SFOUT2_REG [2:0] Controls output signal format and disable for CKOUT2 output buffer. The LVPECL and CMOS output formats draw more current than either LVDS or CML; however, there are restrictions in the allowed output format pin settings so that the maximum power dissipation for the TQFP devices is limited when they are operated at 3.3 V. When there are four enabled LVPECL or CMOS outputs, the fifth output must be disabled. When there are five enabled outputs, there can be no more than three outputs that are either LVPECL or CMOS.</p> <p>000: Reserved 001: Disable 010: CMOS 011: Low swing LVDS 100: Reserved 101: LVPECL 110: CML 111: LVDS</p>
2:0	SFOUT1_REG [2:0]	<p>SFOUT1_REG [2:0] Controls output signal format and disable for CKOUT1 output buffer. The LVPECL and CMOS output formats draw more current than either LVDS or CML; however, there are restrictions in the allowed output format pin settings so that the maximum power dissipation for the TQFP devices is limited when they are operated at 3.3 V. When there are four enabled LVPECL or CMOS outputs, the fifth output must be disabled. When there are five enabled outputs, there can be no more than three outputs that are either LVPECL or CMOS.</p> <p>000: Reserved 001: Disable 010: CMOS 011: Low swing LVDS 100: Reserved 101: LVPECL 110: CML 111: LVDS</p>

Register 6.

Bit	D7	D6	D5	D4	D3	D2	D1	D0
Name	Reserved	SLEEP	SFOUT4_REG [2:0]			SFOUT3_REG [2:0]		
Type	R	R/W	R/W			R/W		

Reset value = 0010 1100

Bit	Name	Function
7	Reserved	Reserved.
6	SLEEP	<p>SLEEP.</p> <p>In sleep mode, the clock outputs are disabled and the maximum amount of internal circuitry is powered down to reduce power dissipation and noise generation. This bit overrides the SFOUTn_REG[2:0] output signal format settings.</p> <p>Note: Output skew is random coming out of SLEEP until a successful ICAL is completed.</p> <p>0: Normal operation 1: Sleep mode</p>
5:3	SFOUT4_REG [2:0]	<p>SFOUT4_REG [2:0].</p> <p>Controls output signal format and disable for CKOUT4 output buffer. The LVPECL and CMOS output formats draw more current than either LVDS or CML; however, there are restrictions in the allowed output format pin settings so that the maximum power dissipation for the TQFP devices is limited when they are operated at 3.3 V. When there are four enabled LVPECL or CMOS outputs, the fifth output must be disabled. When there are five enabled outputs, there can be no more than three outputs that are either LVPECL or CMOS.</p> <p>000: Reserved 001: Disable 010: CMOS 011: Low swing LVDS 100: Reserved 101: LVPECL 110: CML 111: LVDS</p>

2:0	SFOUT3_REG [2:0]	<p>SFOUT3_REG [2:0]. Controls output signal format and disable for CKOUT3 output buffer. The LVPECL and CMOS output formats draw more current than either LVDS or CML; however, there are restrictions in the allowed output format pin settings so that the maximum power dissipation for the TQFP devices is limited when they are operated at 3.3 V. When there are four enabled LVPECL or CMOS outputs, the fifth output must be disabled. When there are five enabled outputs, there can be no more than three outputs that are either LVPECL or CMOS.</p> <p>000: Reserved 001: Disable 010: CMOS 011: Low swing LVDS 100: Reserved 101: LVPECL 110: CML 111: LVDS</p>
-----	------------------	---

Register 7.

Bit	D7	D6	D5	D4	D3	D2	D1	D0
Name	Reserved		SFOUT5_REG [2:0]			FOSREFSEL [2:0]		
Type	R		R/W			R/W		

Reset value = 0010 1010

Bit	Name	Function
7:6	Reserved.	Reserved.

5:3	SFOUT5_REG [2:0]	<p>SFOUT5_REG [2:0] Controls output signal format and disable for CKOUT5 output buffer. The LVPECL and CMOS output formats draw more current than either LVDS or CML; however, there are restrictions in the allowed output format pin settings so that the maximum power dissipation for the TQFP devices is limited when they are operated at 3.3 V. When there are four enabled LVPECL or CMOS outputs, the fifth output must be disabled. When there are five enabled outputs, there can be no more than three outputs that are either LVPECL or CMOS.</p> <p>000: Reserved 001: Disable 010: CMOS 011: Low swing LVDS 100: Reserved 101: LVPECL 110: CML 111: LVDS</p>
2:0	FOSREFSEL [2:0]	<p>FOSREFSEL [2:0]. Selects which input clock is used as the reference frequency for Frequency Off-Set (FOS) alarms.</p> <p>000: XA/XB (External reference) 001: CKIN1 010: CKIN2 011: CKIN3 100: CKIN4 101: Reserved 110: Reserved 111: Reserved</p>

Register 8.

Bit	D7	D6	D5	D4	D3	D2	D1	D0
Name	HLOG_4[1:0]		HLOG_3[1:0]		HLOG_2[1:0]		HLOG_1[1:0]	
Type	R/W		R/W		R/W		R/W	

Reset value = 0000 0000

Bit	Name	Function
7:6	HLOG_4 [1:0]	<p>HLOG_4 [1:0]. 00: Normal operation 01: Holds CKOUT4 output at static logic 0. Entrance and exit from this state will occur without glitches or runt pulses. 10: Holds CKOUT4 output at static logic 1. Entrance and exit from this state will occur without glitches or runt pulses. 11: Reserved</p>

5:4	HLOG_3 [1:0]	HLOG_3 [1:0]. 00: Normal operation 01: Holds CKOUT3 output at static logic 0. Entrance and exit from this state will occur without glitches or runt pulses. 10: Holds CKOUT3 output at static logic 1. Entrance and exit from this state will occur without glitches or runt pulses. 11: Reserved.
3:2	HLOG_2 [1:0]	HLOG_2 [1:0]. 00: Normal operation 01: Holds CKOUT2 output at static logic 0. Entrance and exit from this state will occur without glitches or runt pulses. 10: Holds CKOUT2 output at static logic 1. Entrance and exit from this state will occur without glitches or runt pulses. 11: Reserved.
1:0	HLOG_1 [1:0]	HLOG_1 [1:0]. 00: Normal operation 01: Holds CKOUT1 output at static logic 0. Entrance and exit from this state will occur without glitches or runt pulses. 10: Holds CKOUT1 output at static logic 1. Entrance and exit from this state will occur without glitches or runt pulses. 11: Reserved

Register 9.

Bit	D7	D6	D5	D4	D3	D2	D1	D0
Name	HIST_AVG [4:0]					Reserved	HLOG_5 [1:0]	
Type	R/W					R	R/W	

Reset value = 1100 0000

Bit	Name	Function
7:3	HIST_AVG [4:0]	HIST_AVG [4:0]. Selects amount of averaging time to be used in generating MHIST, the value of M used during digital hold. See Family Reference Manual for settings.
2	Reserved	Reserved.
1:0	HLOG_5 [1:0]	HLOG_5 [1:0]. 00: Normal Operation 01: Holds CKOUT5 output at static logic 0. Entrance and exit from this state will occur without glitches or runt pulses. 10: Holds CKOUT5 output at static logic 1. Entrance and exit from this state will occur without glitches or runt pulses. 11: Reserved

Register 10.

Bit	D7	D6	D5	D4	D3	D2	D1	D0
Name	Reserved		DSBL5_REG	Reserved	DSBL4_REG	DSBL3_REG	DSBL2_REG	DSBL1_REG
Type	R		R/W	R	R/W	R/W	R	R

Reset value = 0000 0000

Bit	Name	Function
7:6	Reserved	Reserved.
5	DSBL5_REG	DSBL5_REG. This bit controls the powerdown and disable of the CKOUT5 output buffer. If disable mode is selected, the NC5_LS output divider is also powered down. 0: CKOUT5 enabled. 1: CKOUT5 disabled.
4	Reserved	Reserved.
3	DSBL4_REG	DSBL4_REG. This bit controls the powerdown and disable of the CKOUT4 output buffer. If disable mode is selected, the NC4 output divider is also powered down. 0'b=CKOUT4 enabled 1'b=CKOUT4 disabled
2	DSBL3_REG	DSBL3_REG. This bit controls the powerdown and disable of the CKOUT3 output buffer. If disable mode is selected, the NC3 output divider is also powered down. 0: CKOUT3 enabled 1: CKOUT3 disabled
1	DSBL2_REG	DSBL2_REG. This bit controls the powerdown and disable of the CKOUT2 output buffer. If disable mode is selected, the NC2 output divider is also powered down. 0: CKOUT2 enabled 1: CKOUT2 disabled
0	DSBL1_REG	DSBL1_REG. This bit controls the powerdown and disable of the CKOUT1 output buffer. If disable mode is selected, the NC1 output divider is also powered down. 0: CKOUT1 enabled 1: CKOUT1 disabled

Register 11.

Bit	D7	D6	D5	D4	D3	D2	D1	D0
Name	ALIGN_THR [2:0]			Reserved	PD_CK4	PD_CK3	PD_CK2	PD_CK1
Type	R/W	R/W	R/W	R	R/W	R/W	R/W	R/W

Reset value = 0100 0000

Bit	Name	Function
7:5	ALIGN_THR [2:0]	<p>ALIGN_THR [2:0]. These bits control the threshold for the alignment error alarm. Input to output sync phase skews that deviate more than the alignment threshold from the ideal value (set by FSYNC_SKEW[16:0]) in either the leading or lagging direction trigger the alignment alarm. Value is in units of Tclkout2.</p> <p>000: 4 001: 8 010: 16 011: 32 100: 48 101: 64 110: 96 111: 128</p>
4	Reserved	Reserved.
3	PD_CK4	<p>PD_CK4. This bit controls the powerdown of the CKIN4 input buffer. 0: CKIN4 enabled 1: CKIN4 disabled</p>
2	PD_CK3	<p>PD_CK3. This bit controls the powerdown of the CKIN3 input buffer. 0: CKIN3 enabled 1: CKIN3 disabled</p>
1	PD_CK2	<p>PD_CK2. This bit controls the powerdown of the CKIN2 input buffer. 0: CKIN2 enabled 1: CKIN2 disabled</p>
0	PD_CK1	<p>PD_CK1. This bit controls the powerdown of the CKIN1 input buffer. 0: CKIN1 enabled 1: CKIN1 disabled</p>

Register 12.

Bit	D7	D6	D5	D4	D3	D2	D1	D0
Name	FPW_VALID	FSYNC_ALIGN_REG	FSYNC_ALIGN_MODE	FSYNC_SWTCH_REG	FSKEW_VALID	FSYNC_SKEW [16:16]	FSYNC_PW [9:8]	
Type	R/W							

Reset value = 1000 1000

Bit	Name	Function
7	FPW_VALID	<p>FPW_VALID.</p> <p>When in frame sync mode (CK_CONFIG_REG=1), before writing either a new FSYNC_PW[9:0] or NC5_LS [19:0] value, this bit must be set to zero. This causes the existing FSYNC_PW [9:0] or NC5_LS[19:0] value to be held by the internal state machine for use while the new values are written. Once the new FSYNC_PW [9:0] or NC5_LS [19:0] values are completely written, set FPW_VALID = 1 to enable their use.</p> <p>0: Memorize existing FSYNC_PW[9:0] and NC5_LS [19:0] values and ignore intermediate register values during write of new FSYNC_PW [9:0] and NC5_LS [19:0] values.</p> <p>1: Use FSYNC_PW[9:0] value directly from registers</p>
6	FSYNC_ALIGN_REG	<p>FSYNC_ALIGN_REG.</p> <p>If FSYNC_ALIGN_PIN=0, this bit controls realignment of FSYNCOUT to the active sync input (CKIN_3 or CKIN_4). If FSYNC_ALIGN_PIN=1, the FSYNC_ALIGN pin controls this function.</p> <p>0: No realignment</p> <p>1: Active</p>
5	FSYNC_ALIGN_MODE	<p>FSYNC_ALIGN_MODE.</p> <p>This bit must be set to 1 when in frame sync mode (when CK_CONFIG_REG = 1).</p>
4	FSYNC_SWTCH_REG	<p>FSYNC_SWTCH_REG.</p> <p>Enables or disables the use of the CKIN3 and CKIN4 loss-of-signal indicators as inputs to the automatic clock selection state machine for the clock configuration mode supporting frame sync switching (CK_CONFIG=1 or CK_CONFIG_REG=1).</p> <p>0: CKIN3 and CKIN4 status not used in clock selection</p> <p>1: CKIN3 and CKIN4 status used in clock selection</p>
3	FSKEW_VALID	<p>FSKEW_VALID.</p> <p>Before writing a new FSYNC_SKEW[16:0] value, this bit must be set to zero, which causes the existing FSYNC_SKEW[16:0] value to be held internally by the skew alignment state machine for use while the new value is being written. Once the new FSYNC_SKEW[16:0] is completely written, set FSKEW_VALID=1 to enable its use.</p> <p>0: Memorize existing FSYNC_SKEW[16:0] value and ignore intermediate register values during write of new FSYNC_SKEW value.</p> <p>1: Use FSYNC_SKEW[[16:0] value directly from registers.</p>

2	FSYNC_SKEW [16:0]	<p>FSYNC_SKEW [16:0]. Phase skew control for FSYNCOUT. The resolution of the skew control is 1/fCKOUT2. Entered values should be less than the FSYNCOUT period. 0 0000 0000 0000 0000=Zero phase skew. 0 0000 0000 0000 0001=Delay of 1 period of CLKOUT_2. 1 0010 1111 1011 1111=Delay of 77,759 periods of CKOUT2. If CKOUT2=622.08 MHz and FSYNCOUT=8 kHz, this delay equals 125 ms - 1/fCKOUT2 and is the maximum value that should be entered. 1 1111 1111 1111 1111=Delay of 131,071 periods of CKOUT2.</p>
1:0	FSYNC_PW [9:0]	<p>FSYNC_PW [9:0]. These bits control the pulse width of the FSYNCOUT signal. The resolution of the pulse width control is 1/fCKOUT2. 0000000000=50% duty cycle. 0000000001=1 period of CKOUT2. 0000000010=2 periods of CKOUT2. 1111111111=1023 periods of CKOUT2.</p>

Register 13.

Bit	D7	D6	D5	D4	D3	D2	D1	D0
Name	FSYNC_PW [7:0]							
Type	R/W							

Reset value = 0000 0001

Bit	Name	Function
7:0	FSYNC_PW [7:0]	FSYNC_PW [7:0]. See Register 12.

Register 14.

Bit	D7	D6	D5	D4	D3	D2	D1	D0
Name	FSYNC_SKEW [15:8]							
Type	R/W							

Reset value = 0000 0000

Bit	Name	Function
7:0	FSYNC_SKEW [15:8]	FSYNC_SKEW [15:8]. See Register 12.

Register 15.

Bit	D7	D6	D5	D4	D3	D2	D1	D0
Name	FSYNC_SKEW [7:0]							
Type	R/W							

Reset value = 0000 0000

Bit	Name	Function
7:0	FSYNC_SKEW [7:0]	FSYNC_SKEW [7:0]. See Register 12.

Register 16.

Bit	D7	D6	D5	D4	D3	D2	D1	D0
Name	CLAT [7:0]							
Type	R/W							

Reset value = 0000 0000

Bit	Name	Function
7:0	CLAT [7:0]	CLAT [7:0]. With INCDEC_PIN=0, this register sets the phase delay for CKOUT_n in units of N1_HS/Fosc. Note: This can take as long as 20 seconds. 01111111: +127 x 1/fOSC (2s compliment) 00000000: 0 10000000: -128 x 1/fOSC (2s compliment)

Register 17.

Bit	D7	D6	D5	D4	D3	D2	D1	D0
Name	FLAT_VALID	FLAT [14:8]						
Type	R/W	R/W						

Reset value = 1000 0000

Bit	Name	Function
7	FLAT_VAILD	FLAT_VAILD. Before writing a new FLAT[14:0] value, this bit must be set to zero, which causes the existing FLAT[14:0] value to be held internally for use while the new value is being written. Once the new FLAT[14:0] value is completely written, set FLAT_VALID = 1 to enable its use. 0: Memorize existing FLAT[14:0] value and ignore intermediate register values during write of new FLAT[14:0] value. 1: Use FLAT[14:0] value directly from registers.
6:0	FLAT [14:0]	FLAT [14:0]. Fine resolution control for overall device latency from input clocks to output clocks. Positive values increase the skew. See DSPLLsim for details.

Register 18.

Bit	D7	D6	D5	D4	D3	D2	D1	D0
Name	FLAT [7:0]							
Type	R/W							

Reset value = 0000 0000

Bit	Name	Function
7:0	FLAT [7:0]	FLAT [7:0]. See Register 17.

Register 19.

Bit	D7	D6	D5	D4	D3	D2	D1	D0
Name	FOS_EN	FOS_THR [1:0]		VALTIME [1:0]		LOCKT [2:0]		
Type	R/W	R/W		R/W		R/W		

Reset value = 0010 1100

Bit	Name	Function
7	FOS_EN	<p>FOS_EN. Frequency offset enable globally disables FOS. See the individual FOS enables (FOSx_EN, register 139). 00: FOS disable 01: FOS enabled by FOSx_EN</p>
6:5	FOS_THR [1:0]	<p>FOS_THR [1:0]. Frequency Offset at which FOS is declared: 00: ± 11 to 12 ppm Stratum 3/3E compliant, with a Stratum 3/3E used for REFCLK. 01: ± 48 to 49 ppm (SMC). 10: ± 30 ppm SONET Minimum Clock (SMC), with a Stratum 3/3E used for REFCLK. 11: ± 200 ppm</p>
4:3	VALTIME [1:0]	<p>VALTIME [1:0]. Sets amount of time for input clock to be valid before the associated alarm is removed. 00: 2 ms 01: 100 ms 10: 200 ms 11: 13 seconds</p>
2:0	LOCKT [2:0]	<p>LOCKT [2:0]. Sets retrigger interval for one shot monitoring phase detector output. One shot is triggered by phase slip in DSPLL. Refer to the Family Reference Manual for more details. 000: 106 ms 001: 53 ms 010: 26.5 ms 011: 13.3 ms 100: 6.6 ms 101: 3.3 ms 110: 1.66 ms 111: 833 us</p>

Register 20.

Bit	D7	D6	D5	D4	D3	D2	D1	D0
Name	Reserved		ALRMOUT_PIN	CK3_BAD_PIN	CK2_BAD_PIN	CK1_BAD_PIN	LOL_PIN	INT_PIN
Type	R		R/W	R/W	R/W	R/W	R/W	R/W

Reset value = 0011 1100

Bit	Name	Function
7:6	Reserved	Reserved.
5	ALRMOUT_PIN	ALRMOUT_PIN. The ALRMOUT status can be reflected on the ALRMOUT output pin. The request to reflect the interrupt status on this pin (INT_PIN=1) overrides the ALRMOUT_PIN request. 0: ALRMOUT not reflected on output pin. Output pin disabled if INT_PIN=0. 1: ALRMOUT reflected to output pin if INT_PIN=0. If INT_PIN=1, interrupt status appears on the output pin and ALRMOUT is not available on an output pin.
4	CK3_BAD_PIN	CK3_BAD_PIN. The CK3_BAD status can be reflected on the C3B output pin. 0: C3B output pin tristated 1: C3B status reflected to output pin
3	CK2_BAD_PIN	CK2_BAD_PIN. The CK2_BAD status can be reflected on the C2B output pin. 0: C2B output pin tristated 1: C2B status reflected to output pin
2	CK1_BAD_PIN	CK1_BAD_PIN. The CK1_BAD status can be reflected on the C1B output pin. 0: C1B output pin tristated 1: C1B status reflected to output pin
1	LOL_PIN	LOL_PIN. The LOL_INT status bit can be reflected on the LOL output pin. 0: LOL output pin tristated 1: LOL_INT status reflected to output pin
0	INT_PIN	INT_PIN. Reflects the interrupt status on the INT output pin. 0: Interrupt status not displayed on INT output pin. If ALRMOUT_PIN = 0, output pin is tristated. 1: Interrupt status reflected to output pin. ALRMOUT_PIN ignored.

Register 21.

Bit	D7	D6	D5	D4	D3	D2	D1	D0
Name	INCDEC_PIN	Reserved	FSYNC_ALIGN_PIN	CK4_ACTV_PIN	CK3_ACTV_PIN	CK2_ACTV_PIN	CK1_ACTV_PIN	CKSEL_PIN
Type	R/W	Force 1	R/W	R/W	R/W	R/W	R/W	R/W

Reset value = 1111 1111

Bit	Name	Function
7	INCDEC_PIN	INCDEC_PIN. Determines how coarse skew adjustments can be made. The adjustments can be made via hardware using the INC/DEC pins or with software via the CLAT register. 0: INC and DEC inputs ignored; use CLAT register to adjust skew. 1: INC and DEC inputs control output phase increment/decrement.
6	Reserved	Reserved.
5	FSYNC_ALIGN_PIN	FSYNC_ALIGN_PIN. Realignment of FSYNCOOUT can be controlled by the FSYNC_ALIGN input pin instead of the FSYNC_ALIGN_REG register bit. 0: FSYNC_ALIGN pin ignored. FSYNC_ALIGN_REG register bit controls FSYNCOOUT realignment. 1: FSYNC_ALIGN pin controls FSYNCOOUT realignment.
4	CK4_ACTV_PIN	CK4_ACTV_PIN. If the CKSEL[1]/CK4_ACTV pin is functioning as the CK4_ACTV output (see CKSEL[1]/CK4_ACTV pin description on CK4_ACTV), the CK4_ACTV_REG status bit can be reflected to the CK4_ACTV output pin using the CK4_ACTV_PIN enable function. 0: CK4_ACTV output pin tristated 1: CK4_ACTV status reflected to output pin.
3	CK3_ACTV_PIN	CK3_ACTV_PIN. If the CKSEL[0]/CK3_ACTV pin is functioning as the CK3_ACTV output (see CKSEL[0]/CK3_ACTV pin description on CK3_ACTV), the CK3_ACTV_REG status bit can be reflected to the CK3_ACTV output pin using the CK3_ACTV_PIN enable function. 0: CK3_ACTV output pin tristated. 1: CK3_ACTV status reflected to output pin.
2	CK2_ACTV_PIN	CK2_ACTV_PIN. The CK2_ACTV_REG status bit can be reflected to the CK2_ACTV output pin using the CK2_ACTV_PIN enable function. 0: CK2_ACTV output pin tristated. 1: CK2_ACTV status reflected to output pin.

1	CK1_ACTV_PIN	CK1_ACTV_PIN. The CK1_ACTV_REG status bit can be reflected to the CK1_ACTV output pin using the CK1_ACTV_PIN enable function. 0: CK1_ACTV output pin tristated. 1: CK1_ACTV status reflected to output pin.
0	CKSEL_PIN	CKSEL_PIN. If manual clock selection is being used, clock selection can be controlled via the CKSEL_REG[1:0] register bits or the CKSEL[1:0] input pins. 0: CKSEL pins ignored. CKSEL_REG[1:0] register bits control clock selection. 1: CKSEL[1:0] input pins controls clock selection.

Register 22.

Bit	D7	D6	D5	D4	D3	D2	D1	D0
Name	FSYNC_ALIGN_POL	FSYNC_POL	Reserved	FSYNCOUT_POL	CK_ACTV_POL	CK_BAD_POL	LOL_POL	INT_POL
Type	R/W	R/W	R	R/W	R/W	R/W	R/W	R/W

Reset value = 1101 1111

Bit	Name	Function
7	FSYNC_ALIGN_POL	FSYNC_ALIGN_POL. Sets the active polarity or edge for the FSYNC_ALIGN input pin. 0: Active low (falling edge). 1: Active high (rising edge).
6	FSYNC_POL	FSYNC_POL. Sets the active polarity and edge for the CKIN_3 and CKIN_4 inputs when used as frame sync inputs. 0: Active low (falling edge). 1: Active high (rising edge).
5	Reserved	Reserved.
4	FSYNCOUT_POL	FSYNCOUT_POL. Controls active polarity of FSYNCOUT. 0: Active low 1: Active high
3	CK_ACTV_POL	CK_ACTV_POL. Sets the active polarity for the CK1_ACTV, CK2_ACTV, CK3_ACTV, and CK4_ACTV signals when reflected on an output pin. 0: Active low 1: Active high

2	CK_BAD_POL	CK_BAD_POL. Sets the active polarity for the C1B, C2B, C3B, and ALRMOUT signals when reflected on output pins. 0: Active low 1: Active high
1	LOL_POL	LOL_POL. Sets the active polarity for the LOL status when reflected on an output pin. 0: Active low 1: Active high
0	INT_POL	INT_POL. Sets the active polarity for the interrupt status when reflected on the INT_ALM output pin. 0: Active low 1: Active high

Register 23.

Bit	D7	D6	D5	D4	D3	D2	D1	D0
Name	Reserved	Reserved	Reserved	LOS4_MSK	LOS3_MSK	LOS2_MSK	LOS1_MSK	LOSX_MSK
Type	R	R	R	R/W	R/W	R/W	R/W	R/W

Reset value = 0001 1111

Bit	Name	Function
7:5	Reserved	Reserved.
4	LOS4_MSK	LOS4_MSK. Determines if a LOS on CKIN4 (LOS4_FLG) is used in the generation of an interrupt. Writes to this register do not change the value held in the LOS4_FLG register. 0: LOS4 alarm triggers active interrupt on INT output (if INT_PIN=1). 1: LOS4_FLG ignored in generating interrupt output.
3	LOS3_MSK	LOS3_MSK. Determines if a LOS on CKIN3 (LOS3_FLG) is used in the generation of an interrupt. Writes to this register do not change the value held in the LOS3_FLG register. 0: LOS3 alarm triggers active interrupt on INT output (if INT_PIN=1). 1: LOS3_FLG ignored in generating interrupt output.
2	LOS2_MSK	LOS2_MSK. Determines if a LOS on CKIN2 (LOS2_FLG) is used in the generation of an interrupt. Writes to this register do not change the value held in the LOS2_FLG register. 0: LOS2 alarm triggers active interrupt on INT output (if INT_PIN=1). 1: LOS2_FLG ignored in generating interrupt output.

1	LOS1_MSK	<p>LOS1_MSK.</p> <p>Determines if a LOS on CKIN1 (LOS1_FLG) is used in the generation of an interrupt. Writes to this register do not change the value held in the LOS1_FLG register.</p> <p>0: LOS1 alarm triggers active interrupt on INT output (if INT_PIN=1).</p> <p>1: LOS1_FLG ignored in generating interrupt output.</p>
0	LOSX_MSK	<p>LOSX_MSK.</p> <p>Determines if a LOS on XA/XB(LOSX_FLG) is used in the generation of an interrupt. Writes to this register do not change the value held in the LOSX_FLG register.</p> <p>0: LOSX alarm triggers active interrupt on INT output (if INT_PIN=1).</p> <p>1: LOSX_FLG ignored in generating interrupt output.</p>

Register 24.

Bit	D7	D6	D5	D4	D3	D2	D1	D0
Name	Reserved		ALIGN_MSK	FOS4_MSK	FOS3_MSK	FOS2_MSK	FOS1_MSK	LOL_MSK
Type	R		R/W	R/W	R/W	R/W	R/W	R/W

Reset value = 0011 1111

Bit	Name	Function
7:6	Reserved	Reserved.
5	ALIGN_MSK	<p>ALIGN_MSK.</p> <p>Determines if an alignment alarm (ALIGN_FLG) is used in the generation of an interrupt. Writes to this register do not change the value held in the ALIGN_FLG register.</p> <p>0: FSYNC alignment alarm triggers active interrupt on INT output (if INT_PIN=1).</p> <p>1: ALIGN_FLG ignored in generating interrupt output.</p>
4	FOS4_MSK	<p>FOS4_MSK.</p> <p>Determines if the FOS4_FLG is used to in the generation of an interrupt. Writes to this register do not change the value held in the FOS4_FLG register.</p> <p>0: FOS4 alarm triggers active interrupt on INToutput (if INT_PIN=1).</p> <p>1: FOS4_FLG ignored in generating interrupt output.</p>
3	FOS3_MSK	<p>FOS3_MSK.</p> <p>Determines if the FOS3_FLG is used in the generation of an interrupt. Writes to this register do not change the value held in the FOS3_FLG register.</p> <p>0: FOS3 alarm triggers active interrupt on INT output (if INT_PIN=1).</p> <p>1: FOS3_FLG ignored in generating interrupt output.</p>
2	FOS2_MSK	<p>FOS2_MSK.</p> <p>Determines if the FOS2_FLG is used in the generation of an interrupt. Writes to this register do not change the value held in the FOS2_FLG register.</p> <p>0: FOS2 alarm triggers active interrupt on INT output (if INT_PIN=1).</p> <p>1: FOS2_FLG ignored in generating interrupt output.</p>

1	FOS1_MSK	FOS1_MSK. Determines if the FOS1_FLG is used in the generation of an interrupt. Writes to this register do not change the value held in the FOS1_FLG register. 0: FOS1 alarm triggers active interrupt on INT output (if INT_PIN=1). 1: FOS1_FLG ignored in generating interrupt output.
0	LOL_MSK	LOL_MSK. Determines if the LOL_FLG is used in the generation of an interrupt. Writes to this register do not change the value held in the LOL_FLG register. 0: LOL alarm triggers active interrupt on INT output (if INT_PIN=1). 1: LOL_FLG ignored in generating interrupt output.

Register 25.

Bit	D7	D6	D5	D4	D3	D2	D1	D0
Name	N1_HS [2:0]			Reserved	NC1_LS [19:16]			
Type	R/W			R	R/W			

Reset value = 0010 0000

Bit	Name	Function
7:5	N1_HS [2:0]	N1_HS [2:0]. Sets value for N1 high speed divider which drives NCn_LS (n = 1 to 4) low-speed divider. 000: N1= 4 Note: Changing the coarse skew via the INC pin is disabled for this value. 001: N1= 5 010: N1=6 011: N1= 7 100: N1= 8 101: N1= 9 110: N1= 10 111: N1= 11
4	Reserved	Reserved.
3:0	NC1_LS [19:16]	NC1_LS [19:0]. Sets value for NC1 low-speed divider, which drives CKOUT1 output. Must be 0 or odd. 00000000000000000000=1 00000000000000000001=2 00000000000000000011=4 00000000000000000101=6 ... 11111111111111111111=2^20 Valid divider values=[1, 2, 4, 6, ..., 2^20].

Register 26.

Bit	D7	D6	D5	D4	D3	D2	D1	D0
Name	NC1_LS [15:8]							
Type	R/W							

Reset value = 0000 0000

Bit	Name	Function
7:0	NC1_LS [15:8]	NC1_LS [15:8]. See Register 25.

Register 27.

Bit	D7	D6	D5	D4	D3	D2	D1	D0
Name	NC1_LS [7:0]							
Type	R/W							

Reset value = 0011 0001

Bit	Name	Function
7:0	NC1_LS [7:0]	NC1_LS [7:0]. See Register 25.

Register 28.

Bit	D7	D6	D5	D4	D3	D2	D1	D0
Name	Reserved				NC2_LS [19:16]			
Type	R				R/W			

Reset value = 0000 0000

Bit	Name	Function
7:4	Reserved	Reserved.
3:0	NC1_LS [19:0]	NC2_LS [19:16]. Sets value for NC2 low-speed divider, which drives CKOUT2 output. Must be 0 or odd. 00000000000000000000=1 00000000000000000001=2 00000000000000000011=4 00000000000000000101=6 ... 11111111111111111111=2^20 Valid divider values=[1, 2, 4, 6, ..., 2^20]

Register 29.

Bit	D7	D6	D5	D4	D3	D2	D1	D0
Name	NC2_LS [15:8]							
Type	R/W							

Reset value = 0000 0000

Bit	Name	Function
7:0	NC2_LS [15:8]	NC2_LS [15:8]. See Register 28.

Register 30.

Bit	D7	D6	D5	D4	D3	D2	D1	D0
Name	NC2_LS [7:0]							
Type	R/W							

Reset value = 0011 0001

Bit	Name	Function
7:0	NC2_LS [7:0]	NC2_LS [7:0]. See Register 28.

Register 31.

Bit	D7	D6	D5	D4	D3	D2	D1	D0
Name	Reserved				NC3_LS [19:16]			
Type	R				R/W			

Reset value = 0000 0000

Bit	Name	Function
7:4	Reserved	Reserved.
3:0	NC3_LS [19:0]	NC3_LS [19:0]. Sets value for NC3 low-speed divider, which drives CKOUT3 output. Must be 0 or odd. 00000000000000000000=1 00000000000000000001=2 00000000000000000011=4 00000000000000000101=6 ... 11111111111111111111=2^20 Valid divider values=[1, 2, 4, 6, ..., 2^20].

Register 32.

Bit	D7	D6	D5	D4	D3	D2	D1	D0
Name	NC3_LS [15:8]							
Type	R/W							

Reset value = 0000 0000

Bit	Name	Function
7:0	NC3_LS [15:8]	NC3_LS [15:8]. See Register 31.

Register 33.

Bit	D7	D6	D5	D4	D3	D2	D1	D0
Name	NC3_LS [7:0]							
Type	R/W							

Reset value = 0011 0001

Bit	Name	Function
7:0	NC3_LS [7:0]	NC3_LS [7:0]. See Register 31.

Register 34.

Bit	D7	D6	D5	D4	D3	D2	D1	D0
Name	Reserved				NC4_LS [19:16]			
Type	R				R/W			

Reset value = 0000 0000

Bit	Name	Function
7:4	Reserved	Reserved.
3:0	NC4_LS [19:0]	<p>NC4_LS [19:0]. Sets value for NC4 low-speed divider, which drives CKOUT4 output. Must be 0 or odd. 00000000000000000000=1 00000000000000000001=2 00000000000000000011=4 00000000000000000101=6 ... 11111111111111111111=2²⁰ Valid divider values=[1, 2, 4, 6, ..., 2²⁰].</p>

Register 35.

Bit	D7	D6	D5	D4	D3	D2	D1	D0
Name	NC4_LS [15:8]							
Type	R/W							

Reset value = 0000 0000

Bit	Name	Function
7:0	NC4_LS [15:8]	<p>NC4_LS [15:8]. See Register 34.</p>

Register 36.

Bit	D7	D6	D5	D4	D3	D2	D1	D0
Name	NC4_LS [7:0]							
Type	R/W							

Reset value = 0011 0001

Bit	Name	Function
7:0	NC4_LS [7:0]	NC4_LS [7:0]. See Register 34.

Register 37.

Bit	D7	D6	D5	D4	D3	D2	D1	D0
Name	Reserved				NC5_LS [19:16]			
Type	R				R/W			

Reset value = 0000 0000

Bit	Name	Function
7:4	Reserved	Reserved.
3:0	NC5_LS [19:0]	<p>NC5_LS [19:0]. Sets value for NC5 low-speed divider, which drives CKOUT5 output. Must be 0 or odd.</p> <p>When CK_CONFIG=0: 00000000000000000000=1 00000000000000000001=2 00000000000000000011=4 00000000000000000101=6 ... 11111111111111111111=2²⁰</p> <p>Valid divider values=[1, 2, 4, 6, ..., 2²⁰]. When CK_CONFIG=1, maximum value limited to 2¹⁹.: 00000000000000000000=1 00000000000000000001=2 00000000000000000011=4 00000000000000000101=6 ... 01111111111111111111=2¹⁹ Valid divider values=[1, 2, 4, 6, ..., 2¹⁹].</p>

Register 38.

Bit	D7	D6	D5	D4	D3	D2	D1	D0
Name	NC5_LS [15:8]							
Type	R/W							

Reset value = 0000 0000

Bit	Name	Function
7:0	NC5_LS [15:8]	NC5_LS [15:8]. See Register 37.

Register 39.

Bit	D7	D6	D5	D4	D3	D2	D1	D0
Name	NC5_LS [7:0]							
Type	R/W							

Reset value = 0011 0001

Bit	Name	Function
7:0	NC5_LS [7:0]	NC5_LS [7:0]. See Register 37.

Si5368

Register 40.

Bit	D7	D6	D5	D4	D3	D2	D1	D0
Name	N2_HS [2:0]			Reserved	N2_LS [19:16]			
Type	R/W			R	R/W			

Reset value = 1100 0000

Bit	Name	Function
7:5	N2_HS [2:0]	N2_HS [2:0]. Sets value for N2 high speed divider which drives NCn_LS (n = 1 to 4) low-speed divider. 000:4 001:5 010:6 011:7 100:8 101:9 110:10 111:11.
4	Reserved	Reserved.
3:0	N2_LS [19:16]	NC2_LS [19:0]. Sets value for N2 low-speed divider, which drives phase detector. 00000000000000000001 = 2 00000000000000000011 = 4 00000000000000000101 = 6 ... 11111111111111111111 = 2 ²⁰ Valid divider values = [2, 4, 6, ..., 2 ²⁰].

Register 41.

Bit	D7	D6	D5	D4	D3	D2	D1	D0
Name	N2_LS [15:8]							
Type	R/W							

Reset value = 0000 0000

Bit	Name	Function
7:0	N2_LS [15:8]	N2_LS [15:8]. See Register 40.

Register 42.

Bit	D7	D6	D5	D4	D3	D2	D1	D0
Name	N2_LS [7:0]							
Type	R/W							

Reset value = 1111 1001

Bit	Name	Function
7:0	N2_LS [7:0]	N2_LS [7:0]. See Register 40.

Register 43.

Bit	D7	D6	D5	D4	D3	D2	D1	D0
Name	Reserved					N31 [18:16]		
Type	R					R/W		

Reset value = 0000 0000

Bit	Name	Function
7:3	Reserved	Reserved.
2:0	N31 [18:0]	N31 [18:0]. Sets value for input divider for CKIN1. 00000000000000000000 = 1 00000000000000000001 = 2 00000000000000000010 = 3 ... 11111111111111111111 = 2 ¹⁹ Valid divider values=[1, 2, 3, ..., 2 ¹⁹].

Si5368

Register 44.

Bit	D7	D6	D5	D4	D3	D2	D1	D0
Name	N31 [15:8]							
Type	R/W							

Reset value = 0000 0000

Bit	Name	Function
7:0	N31 [15:8]	N31 [15:8]. See Register 43.

Register 45.

Bit	D7	D6	D5	D4	D3	D2	D1	D0
Name	N31 [7:0]							
Type	R/W							

Reset value = 0000 1001

Bit	Name	Function
7:0	N31 [7:0]	N31 [7:0]. See Register 43.

Register 46.

Bit	D7	D6	D5	D4	D3	D2	D1	D0
Name	Reserved					N32_[18:16]		
Type	R					R/W		

Reset value = 0000 0000

Bit	Name	Function
7:3	Reserved	Reserved.
2:0	N32_[18:0]	N32_[18:0]. Sets value for input divider for CKIN2. 00000000000000000000 = 1 00000000000000000001 = 2 00000000000000000010 = 3 ... 11111111111111111111 = 2 ¹⁹ Valid divider values=[1, 2, 3, ..., 2 ¹⁹].

Register 47.

Bit	D7	D6	D5	D4	D3	D2	D1	D0
Name	N32_[15:8]							
Type	R/W							

Reset value = 0000 0000

Bit	Name	Function
7:0	N32_[15:8]	N32_[15:8]. See Register 46.

Register 48.

Bit	D7	D6	D5	D4	D3	D2	D1	D0
Name	N32_[7:0]							
Type	R/W							

Reset value = 0000 1001

Bit	Name	Function
7:0	N32_[7:0]	N32_[7:0]. See Register 46.

Register 49.

Bit	D7	D6	D5	D4	D3	D2	D1	D0
Name	Reserved					N33_[18:0]		
Type	R					R/W		

Reset value = 0000 0000

Bit	Name	Function
18:0	N33_[18:0]	N33_[18:0]. Sets value for input divider for CKIN3. 000000000000000000 = 1 000000000000000001 = 2 000000000000000010 = 3 ... 111111111111111111 = 2 ¹⁹ Valid divider values=[1, 2, 3, ..., 2 ¹⁹].

Register 50.

Bit	D7	D6	D5	D4	D3	D2	D1	D0
Name	N33_[15:8]							
Type	R/W							

Reset value = 0000 0000

Bit	Name	Function
7:0	N33_[15:8]	N33_[15:8]. See Register 49.

Register 51.

Bit	D7	D6	D5	D4	D3	D2	D1	D0
Name	N33_[7:0]							
Type	R/W							

Reset value = 0000 1001

Bit	Name	Function
7:0	N33_[7:0]	N33_[7:0]. See Register 49.

Register 52.

Bit	D7	D6	D5	D4	D3	D2	D1	D0
Name	Reserved					N34_[18:16]		
Type	R					R/W		

Reset value = 0000 0000

Bit	Name	Function
7:0	N34_[18:0]	N34_[18:0]. Sets value for input divider for CKIN4. 00000000000000000000 = 1 00000000000000000001 = 2 00000000000000000010 = 3 ... 11111111111111111111 = 2 ¹⁹ Valid divider values=[1, 2, 3, ..., 2 ¹⁹].

Register 53.

Bit	D7	D6	D5	D4	D3	D2	D1	D0
Name	N34_[15:8]							
Type	R/W							

Reset value = 0000 0000

Bit	Name	Function
7:0	N34_[15:8]	N34_[15:8]. See Register 52.

Register 54.

Bit	D7	D6	D5	D4	D3	D2	D1	D0
Name	N34_[7:0]							
Type	R/W							

Reset value = 0000 1001

Bit	Name	Function
7:0	N34_[15:8]	N34_[7:0]. See Register 52.

Register 55.

Bit	D7	D6	D5	D4	D3	D2	D1	D0
Name	Reserved		CLKIN2RATE_[2:0]			CLKIN1RATE[2:0]		
Type	R		R/W			R/W		

Reset value = 0000 0000

Bit	Name	Function
7:6	Reserved	Reserved.
5:3	CLKIN2RATE [2:0]	CLKIN2RATE[2:0]. CKINn frequency selection for FOS alarm monitoring. 000: 10 - 27 MHz 001: 25 - 54 MHz 002: 50 - 105 MHz 003: 95 - 215 MHz 004: 190 - 435 MHz 005: 375 - 710 MHz 006: Reserved 007: Reserved
2:0	CLKIN1RATE [2:0]	CLKIN1RATE[2:0]. CKINn frequency selection for FOS alarm monitoring. 000: 10 - 27 MHz 001: 25 - 54 MHz 002: 50 - 105 MHz 003: 95 - 215 MHz 004: 190 - 435 MHz 005: 375 - 710 MHz 006: Reserved 007: Reserved

Register 56.

Bit	D7	D6	D5	D4	D3	D2	D1	D0
Name	Reserved		CLKIN4RATE_[2:0]			CLKIN3RATE[2:0]		
Type	R		R/W			R/W		

Reset value = 0000 0000

Bit	Name	Function
7:6	Reserved	Reserved.
5:3	CLKIN4RATE [2:0]	CLKIN4RATE[2:0]. CKINn frequency selection for FOS alarm monitoring. 000: 10 - 27 MHz 001: 25 - 54 MHz 002: 50 - 105 MHz 003: 95 - 215 MHz 004: 190 - 435 MHz 005: 375 - 710 MHz 006: Reserved 007: Reserved
2:0	CLKIN3RATE [2:0]	CLKIN3RATE[2:0]. CKINn frequency selection for FOS alarm monitoring. 000: 10 - 27 MHz 001: 25 - 54 MHz 002: 50 - 105 MHz 003: 95 - 215 MHz 004: 190 - 435 MHz 005: 375 - 710 MHz 006: Reserved 007: Reserved

Register 128.

Bit	D7	D6	D5	D4	D3	D2	D1	D0
Name	Reserved				CK4_ACTV_REG	CK3_ACTV_REG	CK2_ACTV_REG	CK1_ACTV_REG
Type	R				R	R	R	R

Reset value = 0010 0000

Bit	Name	Function
7:4	Reserved	Reserved.
3	CK4_ACTV_REG	CK4_ACTV_REG. Indicates if CKIN4 is currently the active clock for the PLL input. 0: CKIN4 is not the active input clock. Either it is not selected or LOS4_INT is 1. 1: CKIN_4 is the active input clock.
2	CK3_ACTV_REG	CK3_ACTV_REG. Indicates if CKIN3 is currently the active clock for the PLL input. 0: CKIN3 is not the active input clock - either it is not selected or LOS3_INT is 1. 1: CKIN3 is the active input clock.
1	CK2_ACTV_REG	CK2_ACTV_REG. Indicates if CKIN2 is currently the active clock for the PLL input. 0: CKIN2 is not the active input clock. Either it is not selected or LOS2_INT is 1. 1: CKIN2 is the active input clock.
0	CK1_ACTV_REG	CK1_ACTV_REG. Indicates if CKIN1 is currently the active clock for the PLL input. 0: CKIN1 is not the active input clock. Either it is not selected or LOS1_INT is 1. 1: CKIN1 is the active input clock.

Register 129.

Bit	D7	D6	D5	D4	D3	D2	D1	D0
Name	Reserved			LOS4_INT	LOS3_INT	LOS2_INT	LOS1_INT	LOSX_INT
Type	R			R	R	R	R	R

Reset value = 0001 1110

Bit	Name	Function
7:5	Reserved	Reserved.
4	LOS4_INT	LOS4_INT. Indicates the LOS status on CKIN4. 0: Normal operation. 1: Internal loss-of-signal alarm on CKIN4 input.
3	LOS3_INT	LOS3_INT. Indicates the LOS status on CKIN3. 0: Normal operation. 1: Internal loss-of-signal alarm on CKIN3 input.
2	LOS2_INT	LOS2_INT. Indicates the LOS status on CKIN2. 0: Normal operation. 1: Internal loss-of-signal alarm on CKIN2 input.
1	LOS1_INT	LOS1_INT. Indicates the LOS status on CKIN1. 0: Normal operation. 1: Internal loss-of-signal alarm on CKIN1 input.
0	LOSX_INT	LOSX_INT. Indicates the LOS status of the external reference on the XA/XB pins. 0: Normal operation. 1: Internal loss-of-signal alarm on XA/XB reference clock input.

Register 130.

Bit	D7	D6	D5	D4	D3	D2	D1	D0
Name	CLAT-PROGRESS	DIGHOLD-VALID	ALIGN_INT	FOS4_INT	FOS3_INT	FOS2_INT	FOS1_INT	LOL_INT
Type	R	R	R	R	R	R	R	R

Reset value = 0000 0001

Bit	Name	Function
7	CLAT-PROGRESS	CLAT Progress. Indicates if the last change in the CLAT register has been processed. 0: Coarse skew adjustment not in progress. 1: Coarse skew adjustment in progress.
6	DIGHOLD-VALID	Digital Hold Valid. Indicates if the digital hold circuit has enough samples of a valid clock to meet digital hold specifications. 0: Indicates digital filter has not been filled. The digital hold output frequency (from the filter) is not valid. 1: Indicates digital hold filter has been filled. The digital hold output frequency is valid.
5	ALIGN_INT	ALIGN_INT. Alignment Alarm Status. 0: Normal operation. 1: Alignment alarm between input and output frame sync signals.
4	FOS4_INT	FOS4_INT. CKIN4 Frequency Offset Status. 0: Normal operation. 1: Internal frequency offset alarm on CKIN4 input.
3	FOS3_INT	FOS3_INT. CKIN3 Frequency Offset Status. 0: Normal operation. 1: Internal frequency offset alarm on CKIN3 input.
2	FOS2_INT	FOS2_INT. CKIN2 Frequency Offset Status. 0: Normal operation. 1: Internal frequency offset alarm on CKIN2 input.
1	FOS1_INT	FOS1_INT. CKIN1 Frequency Offset Status. 0: Normal operation. 1: Internal frequency offset alarm on CKIN1 input.
0	LOL_INT	LOL_INT. PLL Loss of Lock Status. 0: PLL locked. 1: PLL unlocked.

Register 131.

Bit	D7	D6	D5	D4	D3	D2	D1	D0
Name	Reserved			LOS4_FLG	LOS3_FLG	LOS2_FLG	LOS1_FLG	LOSX_FLG
Type	R			R/W	R/W	R/W	R/W	R/W

Reset value = 0001 1111

Bit	Name	Function
7:5	Reserved	Reserved.
4	LOS4_FLG	LOS4_FLG. CKIN4 Loss-of-Signal Flag. 0: Normal operation. 1: Held version of LOS4_INT. Generates active output interrupt if output interrupt pin is enabled (INT_PIN=1) and if not masked by LOS4_MSK bit. Flag cleared by writing location to 0.
3	LOS3_FLG	LOS3_FLG. CKIN3 Loss-of-Signal Flag. 0: Normal operation. 1: Held version of LOS3_INT. Generates active output interrupt if output interrupt pin is enabled (INT_PIN=1) and if not masked by LOS3_MSK bit. Flag cleared by writing location to 0.
2	LOS2_FLG	LOS2_FLG. CKIN2 Loss-of-Signal Flag. 0: Normal operation. 1: Held version of LOS2_INT. Generates active output interrupt if output interrupt pin is enabled (INT_PIN=1) and if not masked by LOS2_MSK bit. Flag cleared by writing location to 0.
1	LOS1_FLG	LOS1_FLG. CKIN1 Loss-of-Signal Flag. 0: Normal operation. 1: Held version of LOS1_INT. Generates active output interrupt if output interrupt pin is enabled (INT_PIN=1) and if not masked by LOS1_MSK bit. Flag cleared by writing location to 0.
0	LOSX_FLG	LOSX_FLG. External reference (signal on pins XA/XB) Loss-of-Signal Flag. 0: Normal operation. 1: Held version of LOSX_INT. Generates active output interrupt if output interrupt pin is enabled (INT_PIN=1) and if not masked by LOSX_MSK bit. Flag cleared by writing location to 0.

Register 132.

Bit	D7	D6	D5	D4	D3	D2	D1	D0
Name	Reserved	ALIGN_FLG	FOS4_FLG	FOS3_FLG	FOS2_FLG	FOS1_FLG	LOL_FLG	ALIGN_ERR [8,8]
Type	R	R/W	R/W	R/W	R/W	R/W	R/W	R

Reset value = 0000 0010

Bit	Name	Function
7	Reserved	Reserved.
6	ALIGN_FLG	ALIGN_FLG. Alignment Alarm Flag. 0: Normal operation. 1: Held version of ALIGN_INT. Generates active output interrupt if output interrupt pin is enabled (INT_PIN=1) and if not masked by ALIGN_MSK bit. Flag cleared by writing location to 0.
5	FOS4_FLG	FOS4_FLG. CLKIN_4 Frequency Offset Flag. 0: Normal operation. 1: Held version of FOS4_INT. Generates active output interrupt if output interrupt pin is enabled (INT_PIN=1) and if not masked by FOS4_MSK bit. Flag cleared by writing location to 0.
4	FOS3_FLG	FOS3_FLG. CLKIN_3 Frequency Offset Flag. 0: Normal operation. 1: Held version of FOS3_INT. Generates active output interrupt if output interrupt pin is enabled (INT_PIN=1) and if not masked by FOS3_MSK bit. Flag cleared by writing location to 0.
3	FOS2_FLG	FOS2_FLG. CLKIN_2 Frequency Offset Flag. 0: Normal operation. 1: Held version of FOS2_INT. Generates active output interrupt if output interrupt pin is enabled (INT_PIN = 1) and if not masked by FOS2_MSK bit. Flag cleared by writing location to 0.
2	FOS1_FLG	FOS1_FLG. CLKIN_1 Frequency Offset Flag. 0: Normal operation. 1: Held version of FOS1_INT. Generates active output interrupt if output interrupt pin is enabled (INT_PIN = 1) and if not masked by FOS1_MSK bit. Flag cleared by writing location to 0.

Si5368

1	LOL_FLG	<p>LOL_FLG. PLL Loss of Lock Flag. 0: PLL locked 1: Held version of LOL_INT. Generates active output interrupt if output interrupt pin is enabled (INT_PIN = 1) and if not masked by LOL_MSK bit. Flag cleared by writing location to 0.</p>
0	ALIGN_ERR [8,8]	<p>ALIGN_ERR [8:0]. Indicates the magnitude of the deviation of the input to output frame sync phase alignment from the ideal value set in the FSYNC_SKEW[16:0] registers. The alignment error is given in units of tCKOUT_2. If the alignment error exceeds 255 fCKOUT_2 clock cycles, ALIGN_ERR[7:0] limits to its maximum value (11111111). The polarity of the phase deviation (leading or lagging) is given by the ALIGN_ERR[8] bit. 00000000=0 11111111=255</p>

Register 133.

Bit	D7	D6	D5	D4	D3	D2	D1	D0
Name	ALIGN_ERR [7:0]							
Type	R							

Reset value = 0000 0000

Bit	Name	Function
7:0	ALIGN_ERR [7:0]	ALIGN_ERR [7:0]. See Register 132.

Register 134.

Bit	D7	D6	D5	D4	D3	D2	D1	D0
Name	PARTNUM_RO [11:4]							
Type	R							

Reset value = 0000 0100

Bit	Name	Function
7:0	PARTNUM_RO [11:0]	PARTNUM_RO [11:0]. Device ID: 0000 0100 0100'b=Si5368

Register 135.

Bit	D7	D6	D5	D4	D3	D2	D1	D0
Name	PARTNUM_RO [3:0]				REVID_RO [3:0]			
Type	R				R			

Reset value = 0100 0010

Bit	Name	Function
7:4	PARTNUM_RO [3:0]	PARTNUM_RO [3:0]. See Register 134.
3:0	REVID_RO [3:0]	REVID_RO [3:0]. Indicates revision number of device. 0000: Revision A 0001: Revision B 0010: Revision C Other codes: Reserved

Register 136.

Bit	D7	D6	D5	D4	D3	D2	D1	D0
Name	RST_REG	ICAL	Reserved				GRADE_RO [1:0]	
Type	R/W	R/W	R				R	

Reset value = 0000 0000

Bit	Name	Function
7	RST_REG	<p>RST_REG. Internal Reset. 0: Normal operation. 1: Reset of all internal logic. Outputs tristated or disabled during reset.</p>
6	ICAL	<p>ICAL. Start an Internal Calibration Sequence. For proper operation, the device must go through an internal calibration sequence. ICAL is a self-clearing bit. Writing a one to this location initiates an ICAL. The calibration is complete once the LOL alarm goes low. A valid stable clock (within 100 ppm) must be present to begin ICAL. Note: Any divider, CLKINn_RATE or BWSEL_REG changes require an ICAL to take effect. Changes in SFOUTn_REG, PD_CKn, or DSBLn_REG will cause a random change in skew until an ICAL is completed. 0: Normal operation. 1: Writing a "1" initiates internal self-calibration. Upon completion of internal self-calibration, ICAL is internally reset to zero.</p>
5:2	Reserved	Reserved.
1:0	GRADE_RO [1:0]	<p>GRADE_RO [1:0]. Indicates maximum clock output frequency of this device. Limits the range of the N1_HS divider. 00: N1_HS x NCn_LS > 4. Maximum clock output frequency = 1.4175 GHz. 01: N1_HS x NCn_LS > 6. Maximum clock output frequency = 808 MHz. 10: N1_HS x NCn_LS > 14. Maximum clock output frequency = 346 MHz. 11: N1_HS x NCn_LS > 20. Maximum clock output frequency = 243 MHz.</p>

Register 138.

Bit	D7	D6	D5	D4	D3	D2	D1	D0
Name	Reserved				LOS4_EN [1:1]	LOS3_EN [1:1]	LOS2_EN [1:1]	LOS1_EN [1:1]
Type	R				R/W	R/W	R/W	R/W

Reset value = 0000 1111

Bit	Name	Function
7:4	Reserved	Reserved.
3	LOS4_EN [1:0]	LOS4_EN [1:0]. Note: LOS1_EN is split between two registers. 00: Disable LOS monitoring. 01: Reserved. 10: Enable LOSA monitoring. 11: Enable LOS monitoring. LOSA is a slower and less sensitive version of LOS. See the Family Reference Manual for details.
2	LOS3_EN [1:0]	LOS3_EN [1:0]. Note: LOS1_EN is split between two registers. 00: Disable LOS monitoring. 01: Reserved. 10: Enable LOSA monitoring. 11: Enable LOS monitoring. LOSA is a slower and less sensitive version of LOS. See the Family Reference Manual for details.
1	LOS2_EN [1:0]	LOS2_EN [1:0]. Note: LOS1_EN is split between two registers. 00: Disable LOS monitoring. 01: Reserved. 10: Enable LOSA monitoring. 11: Enable LOS monitoring. LOSA is a slower and less sensitive version of LOS. See the Family Reference Manual for details.
0	LOS1_EN [1:0]	LOS1_EN [1:0]. Note: LOS1_EN is split between two registers. 00: Disable LOS monitoring. 01: Reserved. 10: Enable LOSA monitoring. 11: Enable LOS monitoring. LOSA is a slower and less sensitive version of LOS. See the Family Reference Manual for details.

Register 139.

Bit	D7	D6	D5	D4	D3	D2	D1	D0
Name	LOS4_EN [0:0]	LOS3_EN [0:0]	LOS2_EN [0:0]	LOS1_EN [0:0]	FOS4_EN	FOS3_EN	FOS2_EN	FOS1_EN
Type	R/W	R/W	R/W	R/W	R/W	R/W	R/W	R/W

Reset value = 1111 1111

Bit	Name	Function
7	LOS4_EN [0:0]	<p>LOS4_EN [0:0]. Enable CKIN1 LOS Monitoring on the Specified Input (1 of 2). Note: LOS1_EN is split between two registers. 00: Disable LOS monitoring. 01: Reserved. 10: Enable LOSA monitoring. 11: Enable LOS monitoring. LOSA is a slower and less sensitive version of LOS. See the family reference manual for details.</p>
6	LOS3_EN [0:0]	<p>LOS3_EN [0:0]. Enable CKIN1 LOS Monitoring on the Specified Input (1 of 2). Note: LOS1_EN is split between two registers. 00: Disable LOS monitoring. 01: Reserved. 10: Enable LOSA monitoring. 11: Enable LOS monitoring. LOSA is a slower and less sensitive version of LOS. See the family reference manual for details.</p>
5	LOS2_EN [0:0]	<p>LOS2_EN. Enable CKIN1 LOS Monitoring on the Specified Input (1 of 2). Note: LOS1_EN is split between two registers. 00: Disable LOS monitoring. 01: Reserved. 10: Enable LOSA monitoring. 11: Enable LOS monitoring. LOSA is a slower and less sensitive version of LOS. See the family reference manual for details.</p>
4	LOS1_EN [0:0]	<p>LOS1_EN [0:0]. Enable CKIN1 LOS Monitoring on the Specified Input (1 of 2). Note: LOS1_EN is split between two registers. 00: Disable LOS monitoring. 01: Reserved. 10: Enable LOSA monitoring. 11: Enable LOS monitoring. LOSA is a slower and less sensitive version of LOS. See the family reference manual for details.</p>

3	FOS4_EN	FOS4_EN. Enables FOS on a Per Channel Basis. 0: Disable FOS monitoring. 1: Enable FOS monitoring.
2	FOS3_EN	FOS3_EN. Enables FOS on a Per Channel Basis. 0: Disable FOS monitoring. 1: Enable FOS monitoring.
1	FOS2_EN	FOS2_EN. Enables FOS on a Per Channel Basis. 0: Disable FOS monitoring. 1: Enable FOS monitoring.
0	FOS1_EN	FOS1_EN. Enables FOS on a Per Channel Basis. 0: Disable FOS monitoring. 1: Enable FOS monitoring.

Register 140.

Bit	D7	D6	D5	D4	D3	D2	D1	D0
Name	INDEPENDENTSKEW1 [7:0]							
Type	R/W							

Reset value = 0000 0000

Bit	Name	Function
7:0	INDEPENDENTSKEW1 [7:0]	INDEPENDENTSKEW1 [7:0]. 8 bit field that represents a twos complement of the phase offset in terms of clocks from the high speed output divider.

Register 141.

Bit	D7	D6	D5	D4	D3	D2	D1	D0
Name	INDEPENDENTSKEW2 [7:0]							
Type	R/W							

Reset value = 0000 0001

Bit	Name	Function
7:0	INDEPENDENTSKEW2 [7:0]	INDEPENDENTSKEW2 [7:0]. 8 bit field that represents a twos complement of the phase offset in terms of clocks from the high speed output divider.

Register 142.

Bit	D7	D6	D5	D4	D3	D2	D1	D0
Name	INDEPENDENTSKEW3 [7:0]							
Type	R/W							

Reset value = 0000 0000

Bit	Name	Function
7:0	INDEPENDENTSKEW3 [7:0]	INDEPENDENTSKEW3 [7:0]. 8 bit field that represents a twos complement of the phase offset in terms of clocks from the high speed output divider.

Register 143.

Bit	D7	D6	D5	D4	D3	D2	D1	D0
Name	INDEPENDENTSKEW4 [7:0]							
Type	R/W							

Reset value = 0000 0000

Bit	Name	Function
7:0	INDEPENDENTSKEW4 [7:0]	INDEPENDENTSKEW4 [7:0]. 8 bit field that represents a twos complement of the phase offset in terms of clocks from the high speed output divider.

Register 144.

Bit	D7	D6	D5	D4	D3	D2	D1	D0
Name	INDEPENDENTSKEW5 [7:0]							
Type	R/W							

Reset value = 0000 0000

Bit	Name	Function
7:0	INDEPENDENTSKEW5 [7:0]	INDEPENDENTSKEW5 [7:0]. 8 bit field that represents a twos complement of the phase offset in terms of clocks from the high speed output divider when CK_CONFIG =0.

Register 185.

Bit	D7	D6	D5	D4	D3	D2	D1	D0
Name	NVM_REVID [7:0]							
Type	R							

Reset value = 0001 0011

Bit	Name	Function
7:0	NVM_REVID [7:0]	NVM_REVID [7:0].

Table 4. CKOUT_ALWAYS_ON and SQICAL Truth Table

CKOUT_ALWAYS_ON	SQICAL	Results	Output to Output Skew Preserved?
0	0	CKOUT OFF until after the first ICAL	N
0	1	CKOUT OFF until after the first successful ICAL (i.e., when LOL is low)	Y
1	0	CKOUT always ON, including during an ICAL	N
1	1	CKOUT always ON, including during an ICAL	Y

Table 5 lists all of the register locations that should be followed by an ICAL after their contents are changed.

Table 5. Register Locations Requiring ICAL

Addr	Register
0	BYPASS_REG
0	CKOUT_ALWAYS_ON
1	CK_PRIOR4
1	CK_PRIOR3
1	CK_PRIOR2
1	CK_PRIOR1
2	BWSEL_REG
4	HIST_DEL
5	ICMOS
7	FOSREFSEL
9	HIST_AVG
10	DSBL5_REG
10	DSBL4_REG
10	DSBL3_REG
10	DSBL2_REG
10	DSBL1_REG
11	PD_CK2
11	PD_CK1
19	FOS_EN
19	FOS_THR
19	VALTIME
19	LOCKT
21	INCDEC_PIN
25	N1_HS
26	NC1_LS
28	NC2_LS
31	NC3_LS

Table 5. Register Locations Requiring ICAL

Addr	Register
34	NC4_LS
37	NC5_LS
40	N2_HS
40	N2_LS
43	N31
46	N32
49	N33
51	N34
55	CLKIN2RATE
55	CLKIN1RATE
56	CLKIN4RATE
56	CLKIN3RATE

5. Ordering Guide

Ordering Part Number	Output Clock Frequency Range	Package	ROHS6, Pb-Free	Temperature Range
Si5368A-C-GQ	2 kHz–945 MHz 970–1134 MHz 1.213–1.417 GHz	100-Pin 14 x 14 mm TQFP	Yes	–40 to 85 °C
Si5368B-C-GQ	2 kHz–808 MHz	100-Pin 14 x 14 mm TQFP	Yes	–40 to 85 °C
Si5368C-C-GQ	2 kHz–346 MHz	100-Pin 14 x 14 mm TQFP	Yes	–40 to 85 °C

Note: Add an R at the end of the device to denote tape and reel options (for example, Si5368-C-GMR).

6. Package Outline: 100-Pin TQFP

Figure 4 illustrates the package details for the Si5368. Table 6 lists the values for the dimensions shown in the illustration.

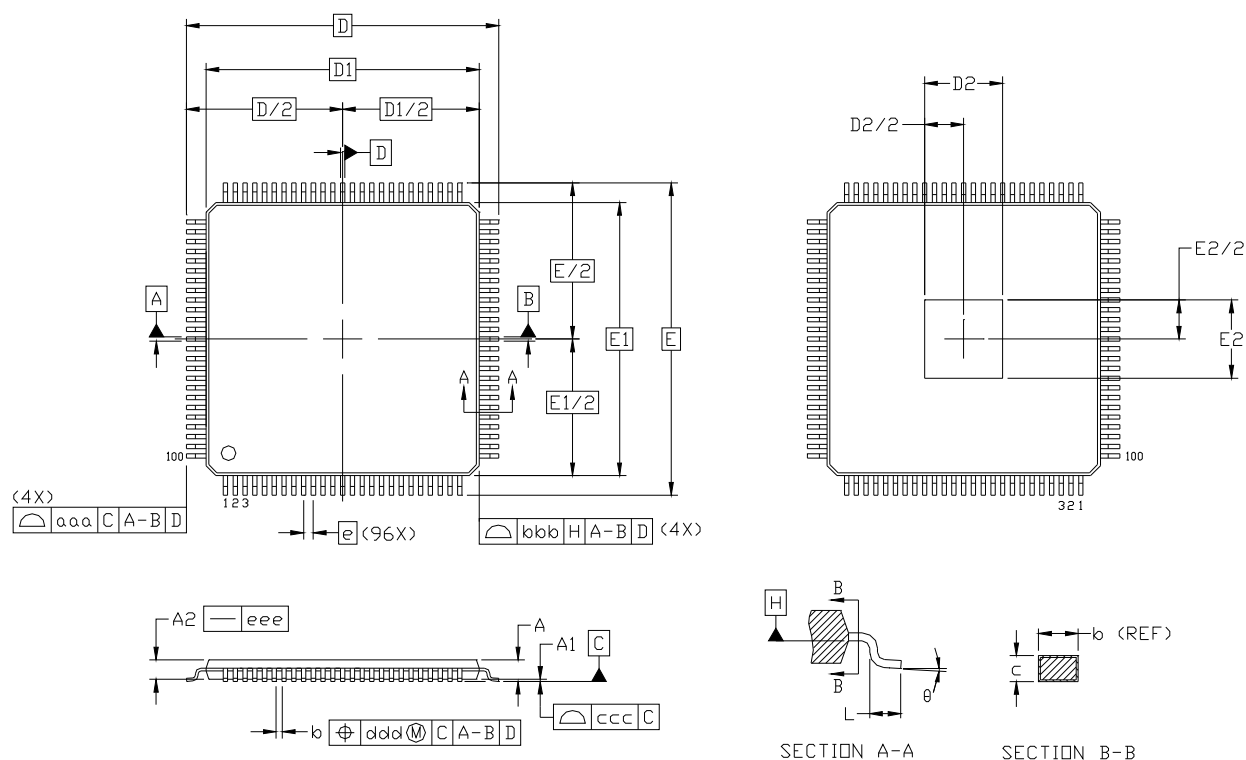

Figure 4. 100-Pin Thin Quad Flat Package (TQFP)

Table 6. 100-Pin Package Diagram Dimensions

Dimension	Min	Nom	Max	Dimension	Min	Nom	Max
A	—	—	1.20	E	16.00 BSC.		
A1	0.05	—	0.15	E1	14.00 BSC.		
A2	0.95	1.00	1.05	E2	3.85	4.00	4.15
b	0.17	0.22	0.27	L	0.45	0.60	0.75
c	0.09	—	0.20	aaa	—	—	0.20
D	16.00 BSC.			bbb	—	—	0.20
D1	14.00 BSC.			ccc	—	—	0.08
D2	3.85	4.00	4.15	ddd	—	—	0.08
e	0.50 BSC.			θ	0°	3.5°	7°

Notes:

1. All dimensions shown are in millimeters (mm) unless otherwise noted.
2. Dimensioning and Tolerancing per ANSI Y14.5M-1994.
3. This package outline conforms to JEDEC MS-026, variant AED-HD.
4. Recommended card reflow profile is per the JEDEC/IPC J-STD-020C specification for Small Body Components.

7. Recommended PCB Layout

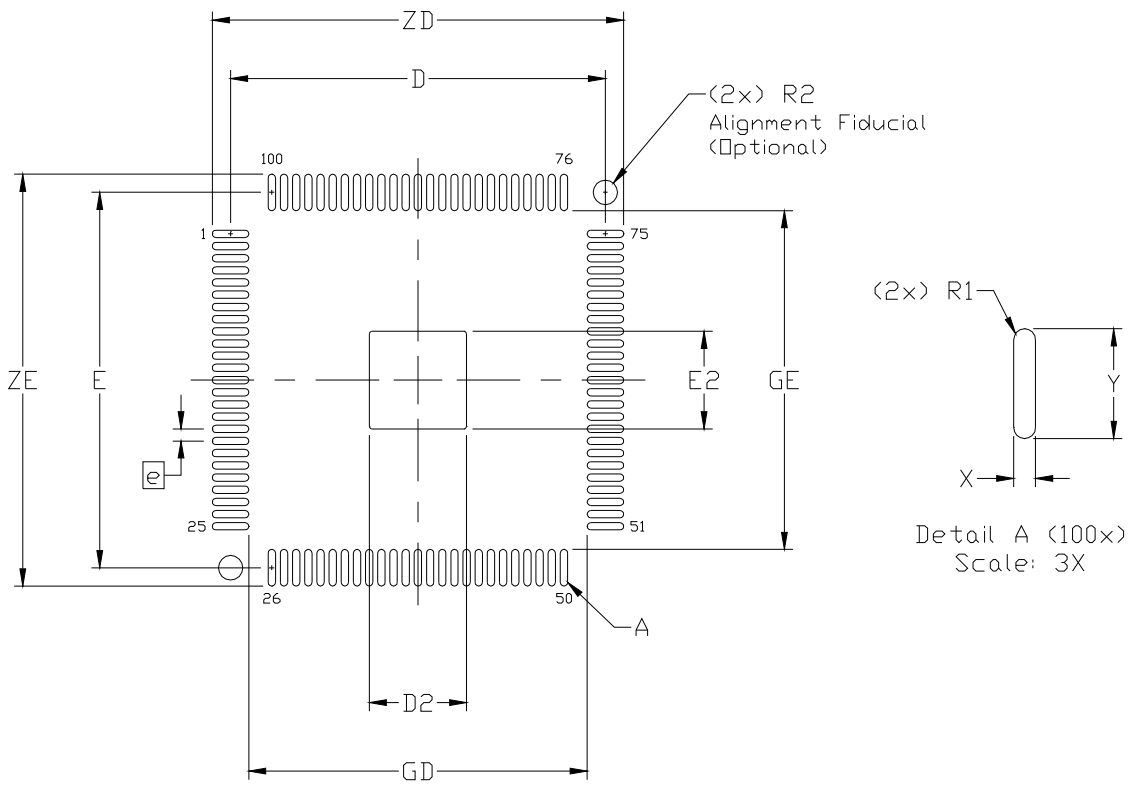

Figure 5. PCB Land Pattern Diagram

Table 7. PCB Land Pattern Dimensions

Dimension	MIN	MAX
e	0.50 BSC.	
E	15.40 REF.	
D	15.40 REF.	
E2	3.90	4.10
D2	3.90	4.10
GE	13.90	—
GD	13.90	—
X	—	0.30
Y	1.50 REF.	
ZE	—	16.90
ZD	—	16.90
R1	0.15 REF	
R2	—	1.00

Notes (General):

1. All dimensions shown are in millimeters (mm) unless otherwise noted.
2. Dimensioning and Tolerancing is per the ANSI Y14.5M-1994 specification.
3. This Land Pattern Design is based on IPC-7351 guidelines.
4. All dimensions shown are at Maximum Material Condition (MMC). Least Material Condition (LMC) is calculated based on a Fabrication Allowance of 0.05 mm.

Notes (Solder Mask Design):

1. All metal pads are to be non-solder mask defined (NSMD). Clearance between the solder mask and the metal pad is to be 60 μm minimum, all the way around the pad.

Notes (Stencil Design):

1. A stainless steel, laser-cut and electro-polished stencil with trapezoidal walls should be used to assure good solder paste release.
2. The stencil thickness should be 0.125 mm (5 mils).
3. The ratio of stencil aperture to land pad size should be 1:1 for the perimeter pads.
4. A 4 x 4 array of 0.80 mm square openings on 1.05 mm pitch should be used for the center ground pad.

Notes (Card Assembly):

1. A No-Clean, Type-3 solder paste is recommended.
2. The recommended card reflow profile is per the JEDEC/IPC J-STD-020C specification for Small Body Components.

DOCUMENT CHANGE LIST

Revision 0.1 to Revision 0.2

- Changed LVTTTL to LVCMOS in Table 2, "Absolute Maximum Ratings," on page 6.
- Updated Figure 2 and Figure 3 on page 8.
- Updated "2. Pin Descriptions: Si5368".
 - Added RATE0 to pin description. By changing RATE[1:0] the part can emulate a Si5367.
 - Changed XA/XB pin description to support both differential and single ended external REFCLK.

Revision 0.2 to Revision 0.3

- Added Figure 1, "Typical Phase Noise Plot," on page 7.
- Updated Figure 2, "Si5368 Typical Application Circuit (I²C Control Mode)," and Figure 3, "Si5368 Typical Application Circuit (SPI Control Mode)," on page 8 to show INC and DEC.
- Updated "2. Pin Descriptions: Si5368".
 - Changed font of register names to *underlined italics*.
- Updated "5. Ordering Guide" on page 72.
- Added "7. Recommended PCB Layout".

Revision 0.3 to Revision 0.4

- Changed V_{DD} specification for 1.8 V.
- Updated Table 1 on page 4.
- Updated Table 2 on page 6.
- Added table under Figure 1 on page 7.
- Updated "1. Functional Description" on page 9.
- Clarified "2. Pin Descriptions: Si5368" on page 10 including correcting pin assignments for RATE0 and RATE1.

Revision 0.4 to Revision 0.41

- Added register map.
- Added 3.3 V operation.
- Removed some TBDs from the AC specifications.

NOTES:

CONTACT INFORMATION

Silicon Laboratories Inc.

400 West Cesar Chavez
Austin, TX 78701
Tel: 1+(512) 416-8500
Fax: 1+(512) 416-9669
Toll Free: 1+(877) 444-3032

Please visit the Silicon Labs Technical Support web page:
<https://www.silabs.com/support/pages/contacttechnicalsupport.aspx>
and register to submit a technical support request.

The information in this document is believed to be accurate in all respects at the time of publication but is subject to change without notice. Silicon Laboratories assumes no responsibility for errors and omissions, and disclaims responsibility for any consequences resulting from the use of information included herein. Additionally, Silicon Laboratories assumes no responsibility for the functioning of undescribed features or parameters. Silicon Laboratories reserves the right to make changes without further notice. Silicon Laboratories makes no warranty, representation or guarantee regarding the suitability of its products for any particular purpose, nor does Silicon Laboratories assume any liability arising out of the application or use of any product or circuit, and specifically disclaims any and all liability, including without limitation consequential or incidental damages. Silicon Laboratories products are not designed, intended, or authorized for use in applications intended to support or sustain life, or for any other application in which the failure of the Silicon Laboratories product could create a situation where personal injury or death may occur. Should Buyer purchase or use Silicon Laboratories products for any such unintended or unauthorized application, Buyer shall indemnify and hold Silicon Laboratories harmless against all claims and damages.

Silicon Laboratories, Silicon Labs, and DSPLL are trademarks of Silicon Laboratories Inc.
Other products or brandnames mentioned herein are trademarks or registered trademarks of their respective holders.