

SYNCHRONOUS ETHERNET/TELECOM JITTER ATTENUATING CLOCK MULTIPLIER

Features

- Provides jitter attenuation and frequency translation between SONET/PDH and Ethernet
- Supports ITU-T G.8262 Synchronous Ethernet equipment slave clocks (EEC option 1 and 2) requirements
- Two clock inputs/two clock outputs
- Input frequency range: 8 kHz–644 MHz
- Output frequency range: 8 kHz–644 MHz
- Very low jitter: 0.23 ps RMS (1.875–20 MHz), 0.47 ps RMS (12 kHz–20 MHz)
- Simple pin control interface
- Selectable loop bandwidth for jitter attenuation: 60 to 8.4 kHz
- Automatic/Manual hitless switching and holdover during loss of inputs clock
- Programmable output clock signal format: LVPECL, LVDS, CML or CMOS
- 40 MHz crystal or XO reference
- Single supply: 1.8, 2.5, or 3.3 V
- On-chip voltage regulator with high PSRR
- Loss of lock and loss of signal alarms
- Small size: 6 x 6 mm, 36-QFN
- Wide temperature range: –40 to +85 °C

Applications

- Synchronous Ethernet line cards
- SONET OC-3/12/48 line cards
- PON OLT/ONU
- Carrier Ethernet switches/routers
- MSAN / DSLAM
- T1/E1/DS3/E3 line cards

Description

The Si5315 is a jitter-attenuating clock multiplier for Gb and 10G Synchronous Ethernet, SONET/SDH, and PDH (T1/E1) applications. The Si5315 accepts dual clock inputs ranging from 8 kHz to 644.53 MHz and generates two equal frequency-multiplied clock outputs ranging from 8 kHz to 644.53 MHz. The input clock frequency and clock multiplication ratio are selectable from a table of popular SyncE and T1/E1 rates. The Si5315 is based on Silicon Laboratories' third-generation DSPLL[®] technology, which provides any-rate frequency synthesis and jitter attenuation in a highly integrated PLL solution that eliminates the need for external VCXO and loop filter components. The DSPLL loop bandwidth is user programmable, providing jitter performance optimization at the application level.

Functional Block Diagram

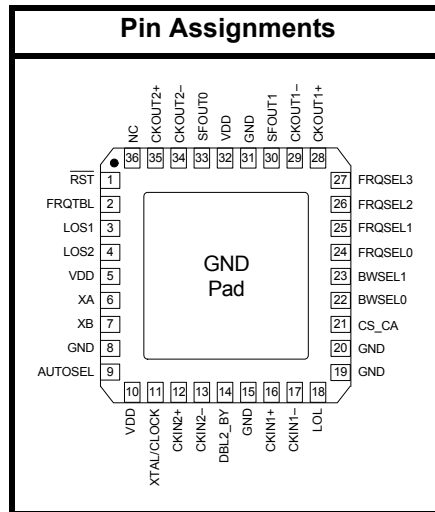
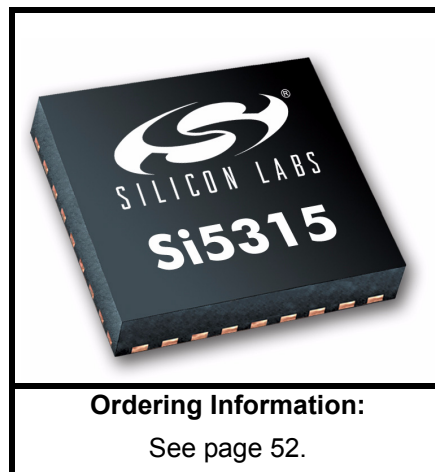
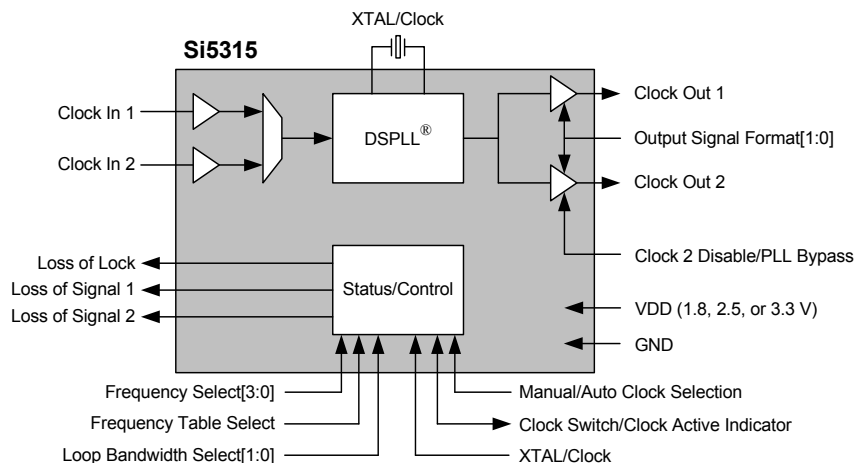



TABLE OF CONTENTS

<u>Section</u>	<u>Page</u>
1. Electrical Specifications	4
1.1. Three-Level (3L) Input Pins (No External Resistors)	12
1.2. Three-Level (3L) Input Pins (With External Resistors)	13
2. System Level Overview	15
3. Functional Description	16
3.1. Overview	16
3.2. PLL Performance	17
4. Frequency Plan Tables	19
4.1. Frequency Multiplication Plan	19
4.2. PLL Self-Calibration	30
4.3. Input Clock Control	32
4.4. Alarms	34
4.5. Holdover Mode	35
4.6. PLL Bypass Mode	36
5. High-Speed I/O	37
5.1. Input Clock Buffers	37
5.2. Output Clock Drivers	39
6. Crystal/Reference Clock Input	41
6.1. Crystal/Reference Clock Selection	42
7. Power Supply Filtering	44
8. Typical Phase Noise Plots	45
8.1. Example: 10G LAN SyncE	45
9. Typical Application Circuit	46
10. Pin Descriptions: Si5315	47
11. Ordering Guide	52
12. Package Outline: 36-Pin QFN	53
13. Recommended PCB Layout	54
14. Si5315 Device Top Mark	56
Document Change List:	57
Contact Information	58

1. Electrical Specifications

Table 1. Recommended Operating Conditions

($V_{DD} = 1.8 \pm 5\%$, $2.5 \pm 10\%$, or $3.3 \text{ V} \pm 10\%$, $T_A = -40$ to $85 \text{ }^\circ\text{C}$)

Parameter	Symbol	Test Condition	Min	Typ	Max	Unit
Temperature Range	T_A		-40	25	85	$^\circ\text{C}$
Supply Voltage	V_{DD}	3.3 V nominal	2.97	3.3	3.63	V
		2.5 V nominal	2.25	2.5	2.75	V
		1.8 V nominal	1.71	1.8	1.89	V

Note: All minimum and maximum specifications are guaranteed and apply across the recommended operating conditions. Typical values apply at nominal supply voltages and an operating temperature of $25 \text{ }^\circ\text{C}$ unless otherwise noted.

Table 2. DC Characteristics

($V_{DD} = 1.8 \pm 5\%$, $2.5 \pm 10\%$, or $3.3 \text{ V} \pm 10\%$, $T_A = -40$ to $85 \text{ }^\circ\text{C}$)

Parameter	Symbol	Test Condition	Min	Typ	Max	Units
Supply Current (Supply current is independent of V_{DD})	I_{DD}	LVPECL Format 644.53125 MHz Out All CKOUTs Enabled ¹	—	251	279	mA
		LVPECL Format 644.53125 MHz Out Only 1 CKOUT Enabled ¹	—	217	243	mA
		CMOS Format 25.00 MHz Out All CKOUTs Enabled ²	—	204	234	mA
		CMOS Format 25.00 MHz Out Only CKOUT1 Enabled ²	—	194	220	mA
CKINn Input Pins						
Input Common Mode Voltage (Input Threshold Voltage)	V_{ICM}	$1.8 \text{ V} \pm 5\%$	0.9	—	1.4	V
		$2.5 \text{ V} \pm 10\%$	1.0	—	1.7	V
		$3.3 \text{ V} \pm 10\%$	1.1	—	1.95	V
Input Resistance	CKN_{RIN}	Single-ended	20	40	60	$k\Omega$
Input Voltage Level Limits	CKN_{VIN}		0	—	V_{DD}	V
Single-ended Input Voltage Swing	V_{ISE}	$f_{CKIN} \leq 212.5 \text{ MHz}$ See Figure 2.	0.2	—	—	V_{PP}
		$f_{CKIN} > 212.5 \text{ MHz}$ See Figure 2.	0.25	—	—	V_{PP}
Differential Input Voltage Swing	V_{ID}	$f_{CKIN} \leq 212.5 \text{ MHz}$ See Figure 2.	0.2	—	—	V_{PP}
		$f_{CKIN} > 212.5 \text{ MHz}$ See Figure 2.	0.25	—	—	V_{PP}

Notes:

1. Refers to Si5315A speed grade.
2. Refers to Si5315B speed grade.
3. This is the amount of leakage that the 3L inputs can tolerate from an external driver. See Figure 3 on page 12.

Table 2. DC Characteristics (Continued) $(V_{DD} = 1.8 \pm 5\%, 2.5 \pm 10\%, \text{ or } 3.3 \text{ V} \pm 10\%, T_A = -40 \text{ to } 85 \text{ }^\circ\text{C})$

Parameter	Symbol	Test Condition	Min	Typ	Max	Units
CKOUTn Output Clocks						
Common Mode	V_{OCM}	LVPECL 100 Ω load line-to-line	$V_{DD} - 1.42$	—	$V_{DD} - 1.25$	V
Differential Output Swing	V_{OD}	LVPECL 100 Ω load line-to-line	1.1	—	1.9	V_{PP}
Single Ended Output Swing	V_{SE}	LVPECL 100 Ω load line-to-line	0.5	—	0.93	V_{PP}
Differential Output Voltage	CKO_{VD}	CML 100 Ω load line-to-line	350	425	500	mV_{PP}
Common Mode Output Voltage	CKO_{VCM}	CML 100 Ω load line-to-line	—	$V_{DD} - 0.36$	—	V
Differential Output Voltage	CKO_{VD}	LVDS 100 Ω load line-to-line	500	700	900	mV_{PP}
		Low swing LVDS 100 Ω load line-to-line	350	425	500	mV_{PP}
Common Mode Output Voltage	CKO_{VCM}	LVDS 100 Ω load line-to-line	1.125	1.2	1.275	V
Output Short to GND	CKO_{ISC}	$V_{DD} = 3.63 \text{ V}$ CML, LVDS, LVPECL	—	80	90	mA
		$V_{DD} = 1.89 \text{ V}$ CML, LVDS	—	45	50	mA
		$V_{DD} = 3.63 \text{ V}$ CMOS	—	165	175	mA
		$V_{DD} = 1.89 \text{ V}$ CMOS	—	65	70	mA
		Disable	—	0.1	0.2	μA
Output Short to V_{DD}	CKO_{ISC+}	$V_{DD} = 3.63 \text{ V}$ CML, LVDS, LVPECL	—	25	30	mA
		$V_{DD} = 1.89 \text{ V}$ CML, LVDS	—	25	30	mA
		$V_{DD} = 3.63 \text{ V}$ CMOS	—	190	200	mA
		$V_{DD} = 1.89 \text{ V}$ CMOS	—	70	80	mA
		Disable	—	1.5	2	μA
Differential Output Resistance	CKO_{RD}	CML, LVPECL, LVDS, Disable	170	200	230	Ω
Common Mode Output Resistance (to V_{DD})	CKO_{RCM}	CML, LVPECL, LVDS	85	100	115	Ω
		Disable	1	—	—	$M\Omega$
Output Voltage Low	CKO_{VOLLH}	CMOS	—	—	0.4	V
Output Voltage High	CKO_{VOHLH}	$V_{DD} = 1.71 \text{ V}$ CMOS	$0.8 \times V_{DD}$	—	—	V
Notes:						
1. Refers to Si5315A speed grade.						
2. Refers to Si5315B speed grade.						
3. This is the amount of leakage that the 3L inputs can tolerate from an external driver. See Figure 3 on page 12.						

Table 2. DC Characteristics (Continued) $(V_{DD} = 1.8 \pm 5\%, 2.5 \pm 10\%, \text{ or } 3.3 \text{ V} \pm 10\%, T_A = -40 \text{ to } 85 \text{ }^\circ\text{C})$

Parameter	Symbol	Test Condition	Min	Typ	Max	Units
Output Drive Current	CKO _{IO}	CMOS Driving into CKO _{VOL} for output low or CKO _{VOH} for output high. CKOUT+ and CKOUT- shorted externally.				
		$V_{DD} = 1.71 \text{ V}$	7.5	—	—	mA
		$V_{DD} = 2.97 \text{ V}$	32	—	—	mA
2-Level LVCMOS Input Pins						
Input Voltage Low	V_{IL}	$V_{DD} = 1.71 \text{ V}$	—	—	0.5	V
		$V_{DD} = 2.25 \text{ V}$	—	—	0.7	V
		$V_{DD} = 2.97 \text{ V}$	—	—	0.8	V
Input Voltage High	V_{IH}	$V_{DD} = 1.89 \text{ V}$	1.4	—	—	V
		$V_{DD} = 2.25 \text{ V}$	1.8	—	—	V
		$V_{DD} = 3.63 \text{ V}$	2.5	—	—	V
Input Low Current	I_{IL}		—	—	50	μA
Input High Current	I_{IH}		—	—	50	μA
Weak Internal Input Pull-up Resistor	R_{PUP}		—	24.6	—	k Ω
Weak Internal Input Pull-down Resistor	R_{PDN}		—	24.6	—	k Ω
3-Level Input Pins						
Input Voltage Low	V_{ILL}		—	—	$0.15 \times V_{DD}$	V
Input Voltage Mid	V_{IMM}		$0.45 \times V_{DD}$	—	$0.55 \times V_{DD}$	V
Input Voltage High	V_{IHH}		$0.85 \times V_{DD}$	—	—	V
Input Low Current	I_{ILL}	See note 3.	-20	—	—	μA
Input Mid Current	I_{IMM}	See note 3.	-2	—	2	μA
Input High Current	I_{IHH}	See note 3.	—	—	20	μA
LVCMOS Output Pins						
Output Voltage Low	V_{OL}	$I_O = 2 \text{ mA}$ $V_{DD} = 1.62 \text{ V}$	—	—	0.4	V
		$I_O = 2 \text{ mA}$ $V_{DD} = 2.97 \text{ V}$	—	—	0.4	V
Output Voltage High	V_{OH}	$I_O = -2 \text{ mA}$ $V_{DD} = 1.62 \text{ V}$	$V_{DD} - 0.4$	—	—	V
		$I_O = -2 \text{ mA}$ $V_{DD} = 2.97 \text{ V}$	$V_{DD} - 0.4$	—	—	V
Single-Ended Reference Clock Input Pin XA (XB with cap to gnd)						
Input Resistance	XA_{RIN}	XTAL/CLOCK = M	8.5	10	11.5	k Ω
Input Voltage Level Limits	XA_{VIN}		0	—	1.2	V
Input Voltage Swing	XA_{VPP}		0.5	—	1.2	V_{PP}
Notes:						
1. Refers to Si5315A speed grade.						
2. Refers to Si5315B speed grade.						
3. This is the amount of leakage that the 3L inputs can tolerate from an external driver. See Figure 3 on page 12.						

Table 2. DC Characteristics (Continued) $(V_{DD} = 1.8 \pm 5\%, 2.5 \pm 10\%, \text{ or } 3.3 \text{ V} \pm 10\%, T_A = -40 \text{ to } 85 \text{ }^\circ\text{C})$

Parameter	Symbol	Test Condition	Min	Typ	Max	Units
Differential Reference Clock Input Pins (XA/XB)						
Input Resistance	XA/XB_{RIN}	XTAL/CLOCK = M	8.5	10	11.5	$k\Omega$
Differential Input Voltage Level Limits	XA/XB_{VIN}		0	—	1.2	V
Input Voltage Swing	XA_{VPP}/XB_{VP} P		0.5	—	1.2	V_{PP} , each
Notes:						
1. Refers to Si5315A speed grade.						
2. Refers to Si5315B speed grade.						
3. This is the amount of leakage that the 3L inputs can tolerate from an external driver. See Figure 3 on page 12.						

Table 3. AC Characteristics
 $(V_{DD} = 1.8 \pm 5\%, 2.5 \pm 10\%, \text{ or } 3.3 \text{ V} \pm 10\%, T_A = -40 \text{ to } 85 \text{ }^\circ\text{C})$

Parameter	Symbol	Test Condition	Min	Typ	Max	Units
Input Frequency	CKN_F		0.008	—	644.53	MHz
CKINn Input Pins						
Input Duty Cycle (Minimum Pulse Width)	CKN_{DC}	Whichever is smaller ¹	40	—	60	%
			2	—	—	ns
Input Capacitance	CKN_{CIN}		—	—	3	pF
Input Rise/Fall Time	CKN_{TRF}	20–80% See Figure 2	—	—	11	ns
CKOUTn Output Pins						
Output Frequency (Output not configured for CMOS or disable)	CKO_{OF}	Note 2	0.008	—	644.53	MHz
		Note 3	0.008	—	125	MHz
Maximum Output Frequency in CMOS Format	CKO_{FMC}		—	—	161.13	MHz
Single Ended Output Rise/Fall (20–80%)	CKO_{TRF}	CMOS Output $V_{DD} = 1.62$ Load = 5 pF	—	—	8	ns
		CMOS Output $V_{DD} = 2.97$ Load = 5 pF	—	—	2	ns
Output Duty Cycle Differential Uncertainty	CKO_{DC}	100 Ω Load Line to Line Measured at 50% Point (not for CMOS)	—	—	± 40	ps
LVCNOS Pins						
Input Capacitance	C_{in}		—	—	3	pF
LVCNOS Output Pins						
Rise/Fall Times	t_{RF}	CLOAD = 20 pf See Figure 2	—	25	—	ns
LOS _n Trigger Window	LOS_{TRIG}	From last CKIN _n \uparrow to internal detection of LOS _n	—	—	750	μ s
LOS _X Trigger Window	LOS_{X-TRIG}	LOL	—	—	10	μ s
Time to Clear LOS Alarm	t_{LOSCLR}	Measured from appearance of valid CKIN to \downarrow of LOS alarm	90	—	220	ms
Time to Declare LOL after LOS	$t_{DECLLOL}$	\uparrow LOS to \uparrow LOL	—	—	2	μ s
Time to Clear LOL after LOS Cleared	t_{CLRLOL}	\downarrow LOS to \downarrow LOL Assume Fold=Fnew, Stable XA-XB reference	—	10	—	ms
Notes:						
1. Assumes N3 does not equal 1. IF N3 = 1, $CKN_{DC} = 50 \mu$ s.						
2. Refers to Si5315A speed grade.						
3. Refers to Si5315B speed grade.						

Table 3. AC Characteristics (Continued)(V_{DD} = 1.8 ±5%, 2.5 ±10%, or 3.3 V ±10%, T_A = -40 to 85 °C)

Parameter	Symbol	Test Condition	Min	Typ	Max	Units
PLL Performance						
Lock Time	t _{LOCKHW}	↑ RST with valid CKIN to ↓ LOL; BW = 100 Hz	—		1.2	sec
Closed Loop Jitter Peaking	J _{PK}		—	0.05	0.1	dB
Jitter Tolerance	J _{TOL}		See 3.2.3. "Jitter Tolerance" on page 18.			ns pk-pk
Recovery Time from Disable Mode	t _{SLP}	Exit Disable mode with valid CKIN to ↓ LOL	—	—	TBD	ms
Minimum Reset Pulse Width	t _{RSTMIN}		1	—	—	μs
Lock Time	t _{LOCKMP}	End of ICAL to ↓ of LOL	—	35	1000	ms
Output Clock Initial Phase Step	t _{P_STEP}	During clock switch CKIN ≥ 19.44 MHz f ₃ ≥ 128 kHz	—	100	200	ps
		f ₃ < 128 kHz	—	2.2	—	ns
Output Clock Phase Slope	t _{P_SLOPE}	During clock switch Per GR-CORE-1244	—	—	61	μs/s
Holdover Frequency Historical Averaging Time	t _{HISTAVG}		—	6.7	—	sec
Holdover Frequency Historical Delay Time	t _{HISTDEL}		—	26.2	—	ms
Holdover Initial Frequency Error	DH _{DFI}	External reference clock stable CKIN selected until entering holdover	—	—	50	±ppb
		External resonator stable CKINn selected until entering holdover	—	50	—	±ppb
Holdover Frequency Stability vs. Power Supply	DH _{FVD}	External crystal	—	0.2	0.5	ppm/ 10% Δ in V _{DD}
		External Reference clock	Tracks external reference clock			
Holdover Frequency Deviation vs. Temperature	DH _{FVT}	External crystal	Tracks external crystal			
		External reference clock	Tracks external reference clock			
Spurious Noise	SP _{SPUR}	Max spur @ n x f ₃ (n ≥ 1, n x f ₃ < 100 MHz)	—	—	-75	dBc
Notes:						
1. Assumes N3 does not equal 1. IF N3 = 1, CKN _{DC} = 50 μs.						
2. Refers to Si5315A speed grade.						
3. Refers to Si5315B speed grade.						

Table 4. Jitter Generation

($V_{DD} = 1.8 \pm 5\%$, $2.5 \pm 10\%$, or $3.3 \text{ V} \pm 10\%$, $T_A = -40$ to $85 \text{ }^\circ\text{C}$)

Parameter	Symbol	Test Condition ^{1,2,3,4}		Min	Typ	Max	GR-253 Spec	Unit
		Measurement Filter (MHz)	DSPLL BW ¹					
Jitter Gen OC-192	J_{GEN}	0.02–80	167 Hz ⁵	—	0.483	0.628	N/A	ps_{rms}
		4–80	167 Hz ⁵	—	0.302	0.392	N/A	ps_{rms}
		0.05–80	167 Hz ⁵	—	0.467	0.607	$1.0 \text{ ps}_{\text{rms}}$ ($0.01 \text{ UI}_{\text{rms}}$)	ps_{rms}
Jitter Gen OC-48	J_{GEN}	0.012–20	167 Hz ⁵	—	0.470	0.611	$4.02 \text{ ps}_{\text{rms}}$ ($0.01 \text{ UI}_{\text{rms}}$)	ps_{rms}
			111 Hz ⁶	—	0.565	0.734	$4.02 \text{ ps}_{\text{rms}}$ ($0.01 \text{ UI}_{\text{rms}}$)	ps_{rms}
IEEE 802.3 GbE RMS Jitter	J_{GEN}	1.875–20	83 Hz ⁶	—	0.232	0.301		ps_{rms}

Notes:

1. BWSEL [1:0] loop bandwidth settings provided in Table 7 on page 20.
2. 40 MHz fundamental mode crystal used as XA/XB input.
3. $V_{DD} = 2.5 \text{ V}$
4. $T_A = 85 \text{ }^\circ\text{C}$
5. Si5315A test condition: $f_{IN} = 19.44 \text{ MHz}$, $f_{OUT} = 156.25 \text{ MHz}$, LVPECL clock input: 1.19 Vppd with 0.5 ns rise/fall time (20–80%), LVPECL clock output.
6. Si5315B test condition: $f_{IN} = 19.44 \text{ MHz}$, $f_{OUT} = 125 \text{ MHz}$, LVPECL clock input: 1.19 Vppd with 0.5 ns rise/fall time (20–80%), LVPECL clock output.

Table 5. Thermal Characteristics

($V_{DD} = 1.8 \pm 5\%$, $2.5 \pm 10\%$, or $3.3 \text{ V} \pm 10\%$, $T_A = -40$ to $85 \text{ }^\circ\text{C}$)

Parameter	Symbol	Test Condition	Min	Typ	Max	Unit
Thermal Resistance Junction to Ambient	θ_{JA}	Still Air	—	32	—	$^\circ\text{C}/\text{W}$
Thermal Resistance Junction to Case	θ_{JC}		—	14	—	$^\circ\text{C}/\text{W}$

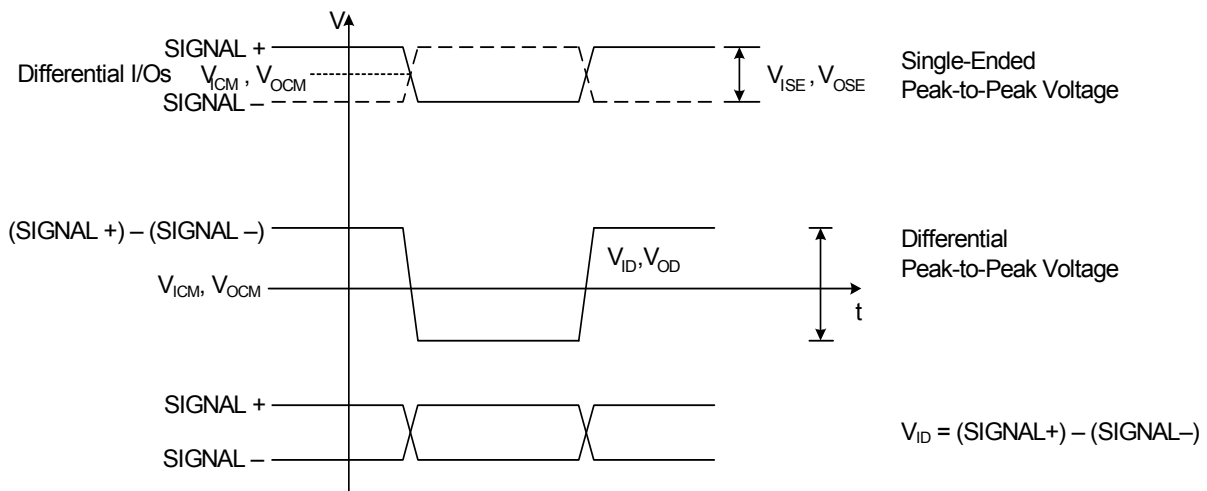

Figure 1. CKIN Voltage Characteristics

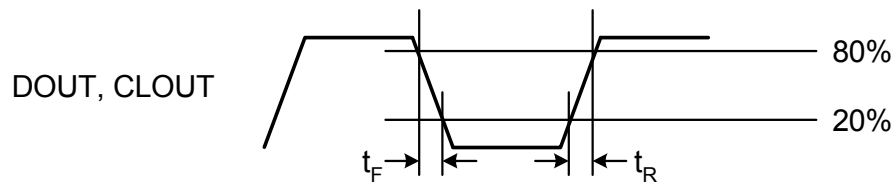

Figure 2. Rise/Fall Time Characteristics

1.1. Three-Level (3L) Input Pins (No External Resistors)

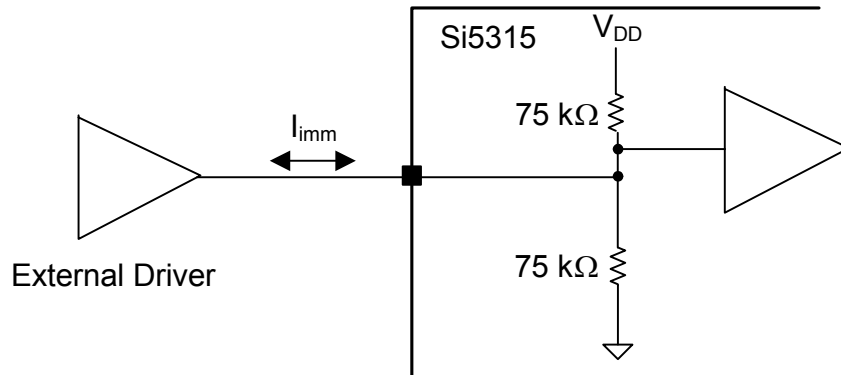
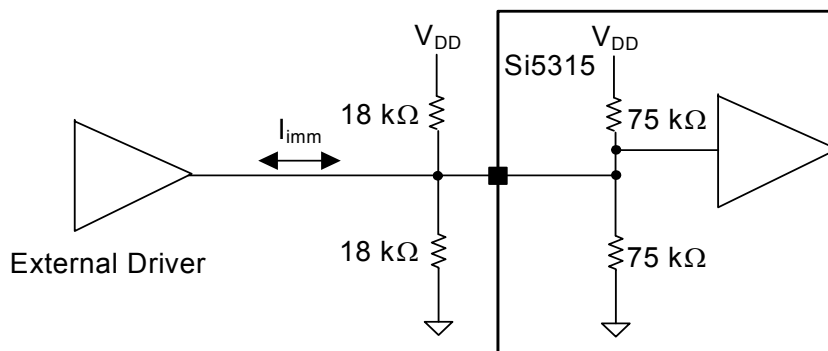

Figure 3. Three Level Input Pins

Parameter	Symbol	Min	Max
Input Voltage Low	V _{ill}	—	0.15 x V _{DD}
Input Voltage Mid	V _{imm}	0.45 x V _{DD}	0.55 x V _{DD}
Input Voltage High	V _{ihh}	0.85 x V _{DD}	—
Input Low Current	I _{ill}	-6 μA	—
Input Mid Current	I _{imm}	-2 μA	2 μA
Input High Current	I _{ihh}	—	6 μA

Note: The above currents are the amount of leakage that the 3L inputs can tolerate from an external driver.

1.2. Three-Level (3L) Input Pins (With External Resistors)



One of eight resistors from a Panasonic EXB-D10C183J (or similar) resistor pack

Figure 4. Three Level Input Pins

Parameter	Symbol	Min	Max
Input Low Current	I_{ill}	$-30 \mu\text{A}$	—
Input Mid Current	I_{imm}	$-11 \mu\text{A}$	$-11 \mu\text{A}$
Input High Current	I_{ihh}	—	$-30 \mu\text{A}$

Note: The above currents are the amount of leakage that the 3L inputs can tolerate from an external driver.

- Any resistor pack may be used.
 - The Panasonic EXB-D10C183J is an example.
 - PCB layout is not critical.
- Resistor packs are only needed if the leakage current of the external driver exceeds the listed currents.
- If a pin is tied to ground or V_{DD} , no resistors are needed.
- If a pin is left open (no connect), no resistors are needed.

Table 6. Absolute Maximum Ratings

Parameter	Symbol	Value	Unit
DC Supply Voltage	V_{DD}	-0.5 to 3.63	V
LVC MOS Input Voltage	V_{DIG}	-0.3 to ($V_{DD} + 0.3$)	V
Operating Junction Temperature	T_{JCT}	-55 to 150	C
Storage Temperature Range	T_{STG}	-55 to 150	C
ESD HBM Tolerance (100 pF, 1.5 k Ω); All pins except CKIN+/CKIN-		2	kV
ESD MM Tolerance; All pins except CKIN+/CKIN-		200	V
ESD HBM Tolerance (100 pF, 1.5 k Ω); CKIN+/CKIN-		700	V
ESD MM Tolerance; CKIN+/CKIN-		150	V
Latch-Up Tolerance		JEESD78 Compliant	
Note: Permanent device damage may occur if the Absolute Maximum Ratings are exceeded. Functional operation should be restricted to the conditions as specified in the operation sections of this data sheet. Exposure to absolute maximum rating conditions for extended periods of time may affect device reliability.			

2. System Level Overview

The Si5315 provides clock translation, jitter attenuation, and clock distribution for high-performance Synchronous Ethernet line card timing applications. The device accepts two clock inputs ranging from 8 kHz to 644.53 MHz and generates two equal frequency, low jitter clock outputs ranging from 8 kHz to 644.53 MHz. For ease of use, the Si5315 is pin controlled to enable simple device configuration of frequency plans, PLL loop bandwidth, and input clock selection. The DSPLL locks to one of two input reference clocks and provides over 200 frequency translations to synchronize output clocks for Ethernet, SONET/SDH, and PDH line cards. The Si5315 implements internal state machines to control hitless switching between input clocks and holdover. Status alarms, loss of signal (LOS) and loss of lock (LOL) are provided on output pins to indicate a change in device status.

This device is designed for systems with line cards that are synchronized to a redundant, centralized telecom or Ethernet backplane. The Si5315 synchronizes to backplane clocks and generates a multiplied, jitter attenuated Ethernet/SONET/SDH clock or PDH clock. A typical system application is shown in Figure 5. The Si5315 translates a 19.44 MHz clock from the telecom backplane to an Ethernet or SONET/SDH clock frequency to the PHY and filters the jitter to ensure compliance with related ITU-T and Telcordia standards.

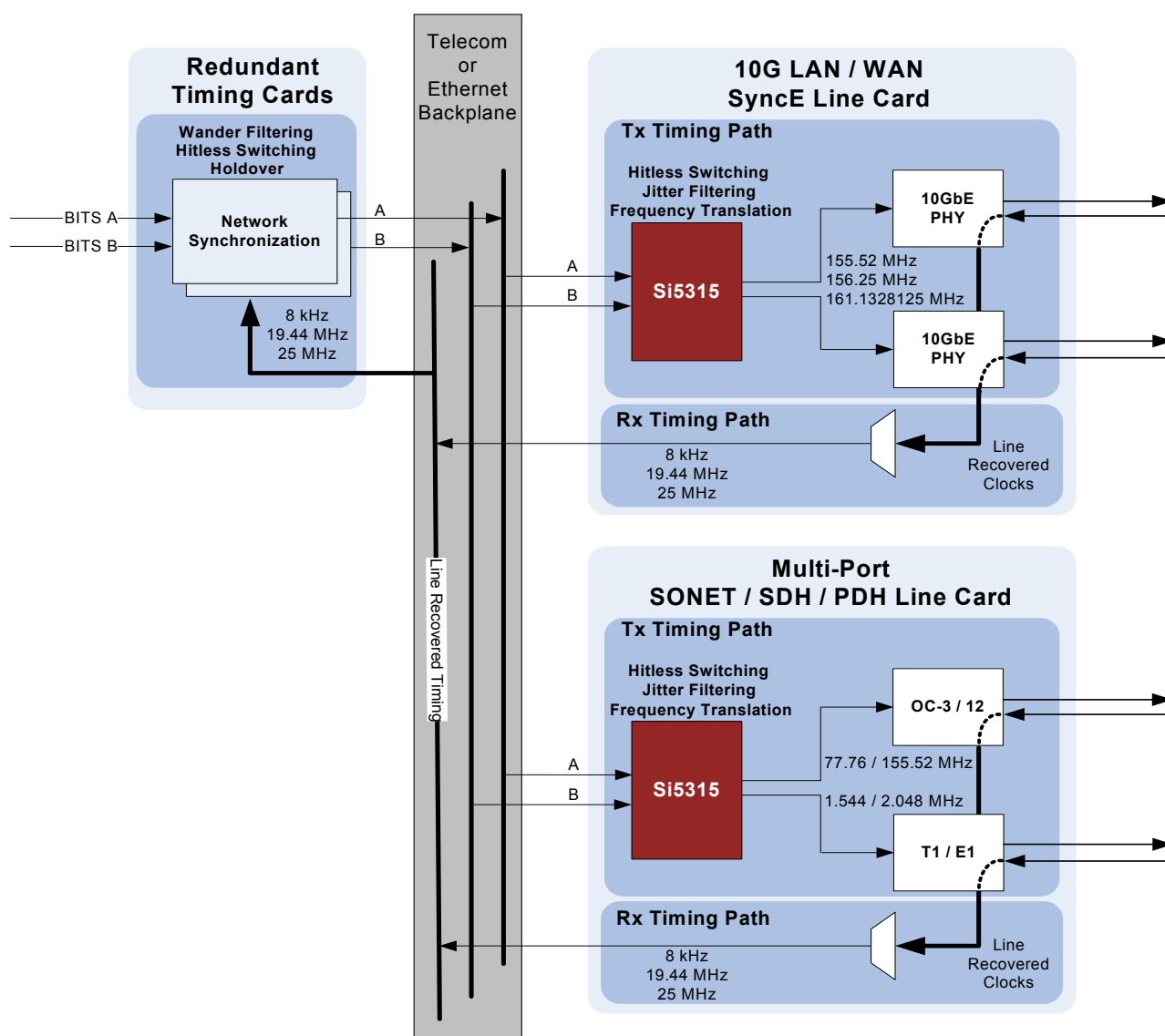

Figure 5. Typical Si5315 Application

3. Functional Description

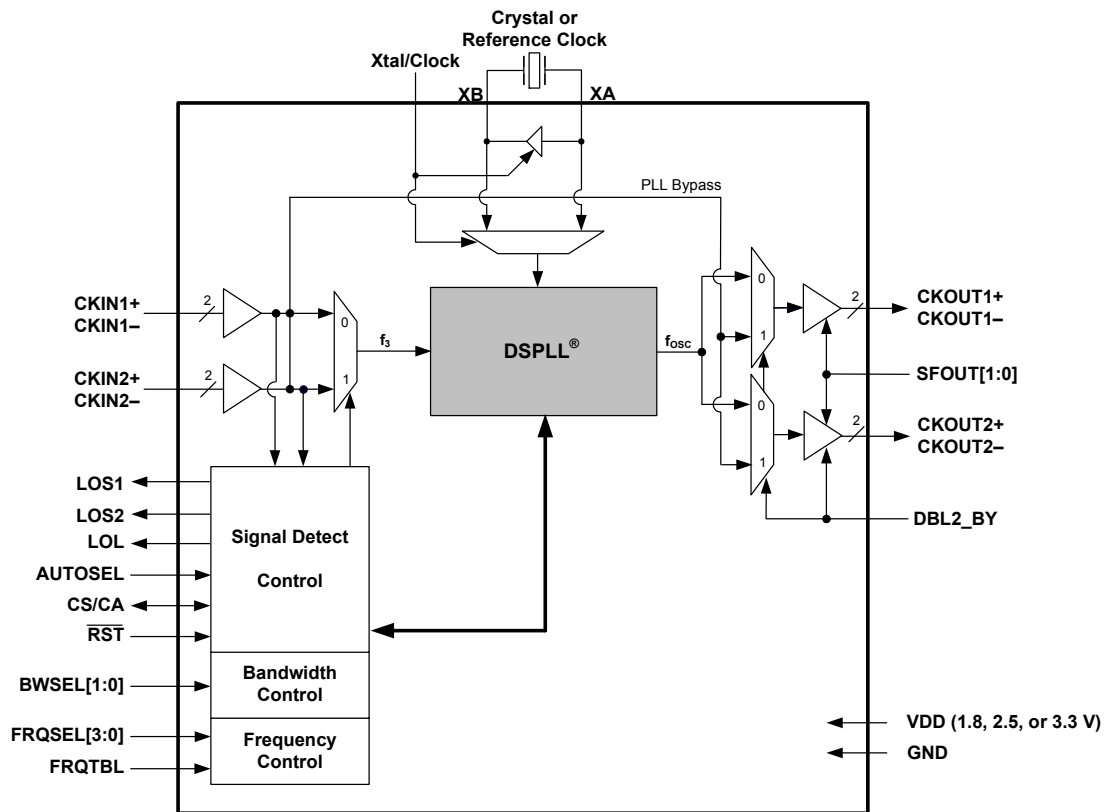

Figure 6. Detailed Block Diagram

3.1. Overview

The Si5315 is a jitter-attenuating precision clock multiplier for Synchronous Ethernet, SONET/SDH, and PDH (T1/E1) applications. The Si5315 accepts dual clock inputs ranging from 8 kHz to 644.53 MHz and generates two frequency-multiplied clock outputs ranging from 8 kHz to 644.53 MHz. The two input clocks are at the same frequency and the two output clocks are at the same frequency. The input clock frequency and clock multiplication ratio are selectable from a look up table of popular SyncE and T1/E1 rates.

The Si5315 is based on Silicon Laboratories' 3rd-generation DSPLL[®] technology, which provides any-rate frequency synthesis and jitter attenuation in a highly integrated PLL solution that eliminates the need for external VCXO and loop filter components. The Si5315 PLL loop bandwidth is selectable via the BWSEL[1:0] pins and supports a range from 60 to 8.4 kHz.

The Si5315 supports hitless switching between the two input clocks in compliance with ITU-T G.8262 and Telcordia GR-253-CORE and GR-1244-CORE. This feature greatly minimizes the propagation of phase transients to the clock outputs during an input clock transition (<200 ps typ). Manual and automatic revertive and non-revertive input clock switching options are available via the AUTOSEL input pin. The Si5315 monitors both input clocks for loss-of-signal and provides a LOS alarm when it detects missing pulses on either input clock. The device monitors the lock status of the PLL. The lock detect algorithm works by continuously monitoring the phase of the input clock in relation to the phase of the feedback clock. The Si5315 provides a holdover capability that allows the device to continue generation of a stable output clock when the selected input reference is lost.

The Si5315 has two differential clock outputs. The signal format of the clock outputs is programmable to support LVPECL, LVDS, CML, or CMOS loads. The second clock output can be powered down to minimize power consumption. For system-level debugging, a bypass mode is available which drives the output clock directly from the input clock, bypassing the internal DSPLL. The device operates from a single 1.8, 2.5, or 3.3 V supply.

3.2. PLL Performance

The Si5315 provides extremely low jitter generation, a well-controlled jitter transfer function, and high jitter tolerance due to the high level of integration.

3.2.1. Jitter Generation

Jitter generation is defined as the amount of jitter produced at the output of the device with a jitter free input clock. Generated jitter arises from sources within the VCO and other PLL components. Jitter generation is a function of the PLL bandwidth setting. Higher loop bandwidth settings may result in lower jitter generation, but may result in less attenuation of jitter that might be present on the input clock signal.

3.2.2. Jitter Transfer

Jitter transfer is defined as the ratio of output signal jitter to input signal jitter for a specified jitter frequency. The jitter transfer characteristic determines the amount of input clock jitter that passes to the outputs. The DSPLL technology used in the Si5315 provides tightly controlled jitter transfer curves because the PLL gain parameters are determined largely by digital circuits which do not vary over supply voltage, process, and temperature. In a system application, a well-controlled transfer curve minimizes the output clock jitter variation from board to board and provides more consistent system level jitter performance.

The jitter transfer characteristic is a function of the loop bandwidth setting. Lower bandwidth settings result in more jitter attenuation of the incoming clock, but may result in higher jitter generation. Figure 7 shows the jitter transfer curve mask.

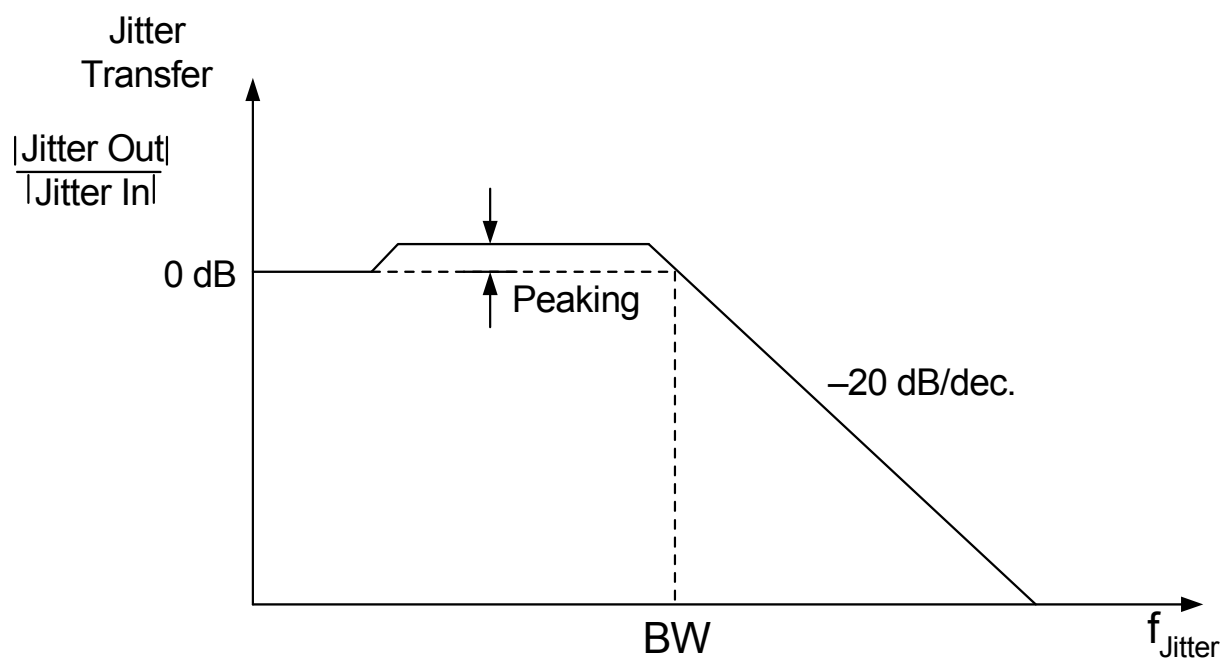

Figure 7. PLL Jitter Transfer Mask/Template

3.2.3. Jitter Tolerance

Jitter tolerance is defined as the maximum peak-to-peak sinusoidal jitter that can be present on the incoming clock before the DSPLL loses lock. The tolerance is a function of the jitter frequency, because tolerance improves for lower input jitter frequency.

The jitter tolerance of the DSPLL is a function of the loop bandwidth setting. Figure 8 shows the general shape of the jitter tolerance curve versus input jitter frequency. For jitter frequencies above the loop bandwidth, the tolerance is a constant value A_{j0} . Beginning at the PLL bandwidth, the tolerance increases at a rate of 20 dB/decade for lower input jitter frequencies.

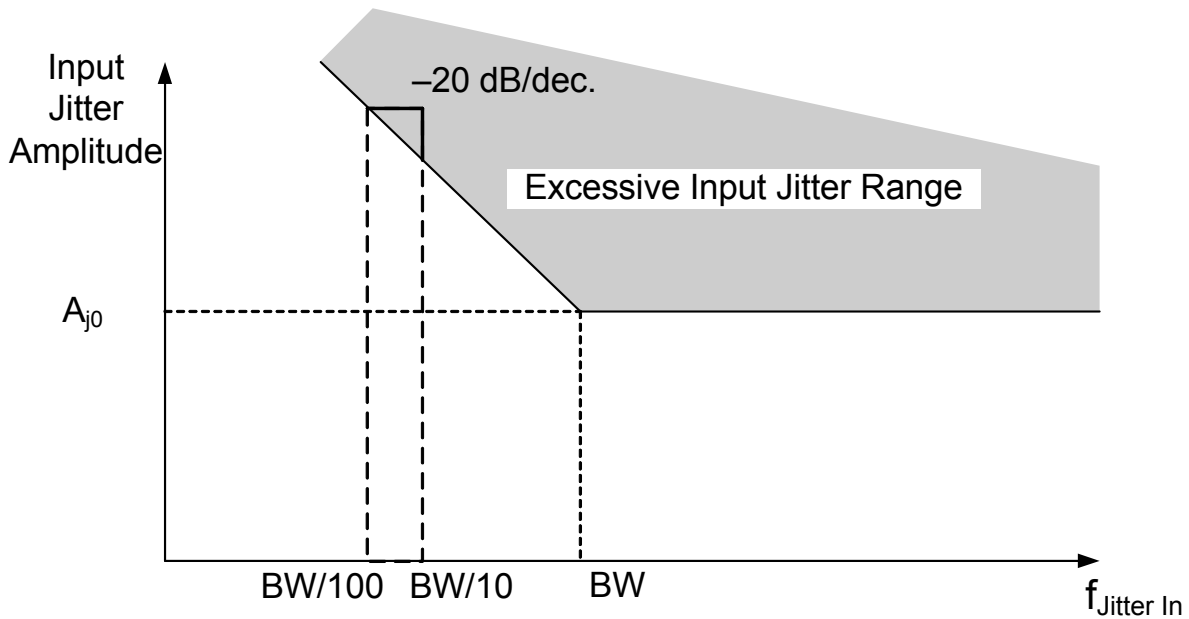

Figure 8. Jitter Tolerance Mask/Template

The equation for the high frequency jitter tolerance can be expressed as a function of the PLL loop bandwidth (i.e., BW):

$$A_{j0} = \frac{5000}{BW} \text{ ns pk-pk}$$

For example, the jitter tolerance when $f_{\text{in}} = 19.44 \text{ MHz}$, $f_{\text{out}} = 161.13 \text{ MHz}$ and the loop bandwidth (BW) is 113 Hz:

$$A_{j0} = \frac{5000}{113} = 44.24 \text{ ns pk-pk}$$

3.2.4. Jitter Attenuation Performance

The Internal VCO uses the reference clock on the XA/XB pins as its reference for jitter attenuation. The XA/XB pins support either a crystal input or an input buffer single-ended or differential clock input, such that an external oscillator can become the reference source. In either case, the device accepts a wide margin in absolute frequency of the reference input. (See 4.5. "Holdover Mode" on page 35.) In holdover, the Si5315's output clock stability matches the reference supplied on the XA/XB pins. The external crystal or reference clock must be selected based on the stability requirements of the application if holdover is a key requirement.

However, care must be exercised in certain areas for optimum performance. For examples of connections to the XA/XB pins, refer to 6. "Crystal/Reference Clock Input" on page 41.

4. Frequency Plan Tables

For ease of use, the Si5315 is pin controlled to enable simple device configuration of the frequency plan and PLL loop bandwidth via a predefined look up table. The DSPLL has been optimized for each frequency multiplication and PLL loop bandwidth provided in Table 7 on page 20.

Many of the control inputs are three levels: High, Low, and Medium. High and Low are standard voltage levels determined by the supply voltage: V_{DD} and Ground. If the input pin is left floating, it is driven to nominally half of V_{DD} . Effectively, this creates three logic levels for these controls. See sections 7. "Power Supply Filtering" on page 44 and 1.2. "Three-Level (3L) Input Pins (With External Resistors)" on page 13 for additional information.

4.1. Frequency Multiplication Plan

The input to output clock multiplication is set by the 3-level FRQSEL[3:0] pins. The device provides a wide range of commonly used SyncE, SONET/SDH, and PDH frequency translations. The CKIN1 and CKIN2 inputs must be the same frequency as specified in Table 7. Both CKOUT1 and CKOUT2 outputs are at the same frequency.

4.1.1. PLL Loop Bandwidth Plan

The Si5315's loop bandwidth ranges from 60 Hz to 8.4 kHz. For each frequency multiplication, its corresponding loop bandwidth is provided in a simple look up table. (See Table 7 on page 20.) The loop bandwidth (BW) is digitally programmable using the 3-level BWSEL [1:0] and FRQTBL input pins.

Table 7. Look Up Tables for Clock Multiplication and Loop Bandwidth Settings

Plan #	f _{IN} (MHz)	f _{OUT} (MHz)	FRQTBL	FRQSEL [3:0]	Loop Bandwidth Selection (Hz), BWSEL[1:0]							
					LM	LH	ML	MM	MH	HL	HH	
1	0.008	0.008	L	LLLL	257	60	—	—	—	—	—	—
2	0.008	1.544	L	LLLM	257	60	—	—	—	—	—	—
3	0.008	2.048	L	LLLH	257	60	—	—	—	—	—	—
4	0.008	8.192	L	LLML	257	60	—	—	—	—	—	—
5	0.008	19.44	L	LLMM	257	60	—	—	—	—	—	—
6	0.008	25	L	LLMH	257	60	—	—	—	—	—	—
7	0.008	32.768	L	LLHL	257	60	—	—	—	—	—	—
8	0.008	34.368	M	LLLL	257	60	—	—	—	—	—	—
9	0.008	38.88	M	LLLM	257	60	—	—	—	—	—	—
10	0.008	44.736	M	LLLH	257	60	—	—	—	—	—	—
11	0.008	51.84	M	LLML	257	60	—	—	—	—	—	—
12	0.008	65.536	M	LLMM	257	—	—	—	—	—	—	—
13	0.008	77.76	M	LLMH	257	60	—	—	—	—	—	—
14	0.008	125	M	LLHL	257	60	—	—	—	—	—	—
15	0.008	155.52	H	LLLL	257	60	—	—	—	—	—	—
16	0.008	156.25	H	LLLM	257	60	—	—	—	—	—	—
17	0.008	311.04	H	LLLH	257	60	—	—	—	—	—	—
18	0.008	312.5	H	LLML	257	60	—	—	—	—	—	—
19	0.008	622.08	H	LLMM	257	60	—	—	—	—	—	—
20	1.544	0.008	L	LLHM	257	60	—	—	—	—	—	—
21	1.544	1.544	L	LLHH	—	—	6047	1451	359	179	89	89

Notes:

1. F_{IN} and F_{OUT} frequency values may be rounded off. For exact multiplication ratios, please contact Silicon Labs.
2. Si5315A supports all frequency plans.
3. Si5315B supports output frequency plans up to 125 MHz.

Table 7. Look Up Tables for Clock Multiplication and Loop Bandwidth Settings (Continued)

Plan #	f _{IN} (MHz)	f _{OUT} (MHz)	FRQTBL	FRQSEL [3:0]	Loop Bandwidth Selection (Hz), BWSEL[1:0]								
					LM	LH	ML	MM	MH	HL	HH		
22	1.544	2.048	L	LMLL	257	60	—	—	—	—	—	—	—
23	1.544	8.192	L	LMLM	257	60	—	—	—	—	—	—	—
24	1.544	19.44	L	LMLH	257	60	—	—	—	—	—	—	—
25	1.544	25	L	LMMM	257	60	—	—	—	—	—	—	—
26	1.544	32.768	L	LMMH	257	60	—	—	—	—	—	—	—
27	1.544	34.368	M	LLHM	257	60	—	—	—	—	—	—	—
28	1.544	38.88	M	LLHH	257	60	—	—	—	—	—	—	—
29	1.544	44.736	M	LMLL	257	60	—	—	—	—	—	—	—
30	1.544	51.84	M	LMLM	257	60	—	—	—	—	—	—	—
31	1.544	65.536	M	LMLH	257	—	—	—	—	—	—	—	—
32	1.544	77.76	M	LMMM	257	60	—	—	—	—	—	—	—
33	1.544	125	M	LMMH	257	60	—	—	—	—	—	—	—
34	1.544	155.52	H	LLMH	257	60	—	—	—	—	—	—	—
35	1.544	156.25	H	LLHL	257	60	—	—	—	—	—	—	—
36	1.544	311.04	H	LLHM	257	60	—	—	—	—	—	—	—
37	1.544	312.5	H	LLHH	257	60	—	—	—	—	—	—	—
38	1.544	622.08	H	LMLL	257	60	—	—	—	—	—	—	—
39	2.048	0.008	L	LMMH	2089	485	240	59	—	—	—	—	—
40	2.048	1.544	L	LMHL	1037	242	119	—	—	—	—	—	—
41	2.048	2.048	L	LMHM	—	—	3949	959	238	118	59	—	—
42	2.048	8.192	L	LMHH	—	—	3949	959	238	118	59	—	—
43	2.048	19.44	L	LHLL	—	—	3946	958	238	118	59	—	—

Notes:

1. F_{IN} and F_{OUT} frequency values may be rounded off. For exact multiplication ratios, please contact Silicon Labs.
2. Si5315A supports all frequency plans.
3. Si5315B supports output frequency plans up to 125 MHz.

Table 7. Look Up Tables for Clock Multiplication and Loop Bandwidth Settings (Continued)

Plan #	f _{IN} (MHz)	f _{OUT} (MHz)	FRQTBL	FRQSEL [3:0]	Loop Bandwidth Selection (Hz), BWSEL[1:0]								
					LM	LH	ML	MM	MH	HL	HH		
44	2.048	25	L	LHLM	2087	485	240	—	—	—	—	—	—
45	2.048	32.768	L	LHLH	—	—	3947	959	238	118	59	—	—
46	2.048	34.368	M	LMMH	—	8163	3935	958	238	118	—	—	—
47	2.048	38.88	M	LMHL	—	—	3946	958	238	118	59	—	—
48	2.048	44.736	M	LMHM	—	3983	1944	477	118	59	—	—	—
49	2.048	51.84	M	LMHH	—	—	3946	958	238	118	59	—	—
50	2.048	65.536	M	LHLL	—	8185	3940	958	238	118	—	—	—
51	2.048	77.76	M	LHLM	—	—	3946	958	238	118	59	—	—
52	2.048	125	M	LHLH	1037	242	119	—	—	—	—	—	—
53	2.048	155.52	H	LMLM	—	—	3946	958	238	118	59	—	—
54	2.048	156.25	H	LMLH	1037	242	119	—	—	—	—	—	—
55	2.048	311.04	H	LMMM	—	—	3946	958	238	118	59	—	—
56	2.048	312.5	H	LMMM	1037	242	119	—	—	—	—	—	—
57	2.048	622.08	H	LMMH	—	—	3946	958	238	118	59	—	—
58	8.192	0.008	L	LHML	2089	485	240	59	—	—	—	—	—
59	8.192	1.544	L	LHMM	1037	242	119	—	—	—	—	—	—
60	8.192	2.048	L	LHMH	—	—	6434	1541	381	190	95	—	—
61	8.192	8.192	L	LHHL	—	—	6434	1541	381	190	95	—	—
62	8.192	19.44	L	LHHM	—	—	3946	958	238	118	59	—	—
63	8.192	25	L	LHHH	2087	485	240	—	—	—	—	—	—
64	8.192	32.768	L	MLLL	—	—	6431	1541	381	190	95	—	—
65	8.192	34.368	M	LHML	—	8163	3935	958	238	118	—	—	—

Notes:

1. F_{IN} and F_{OUT} frequency values may be rounded off. For exact multiplication ratios, please contact Silicon Labs.
2. Si5315A supports all frequency plans.
3. Si5315B supports output frequency plans up to 125 MHz.

Table 7. Look Up Tables for Clock Multiplication and Loop Bandwidth Settings (Continued)

Plan #	f _{IN} (MHz)	f _{OUT} (MHz)	FRQTBL	FRQSEL [3:0]	Loop Bandwidth Selection (Hz), BWSEL[1:0]							
					LM	LH	ML	MM	MH	HL	HH	
66	8.192	38.88	M	LHMM	—	—	3946	958	238	118	59	
67	8.192	44.736	M	LHMH	—	3983	1944	477	118	59	—	
68	8.192	51.84	M	LHHL	—	—	3946	958	238	118	59	
69	8.192	65.536	M	LHHM	—	—	6411	1539	381	190	95	
70	8.192	77.76	M	LHHH	—	—	3946	958	238	118	59	
71	8.192	125	M	MLLL	1037	242	119	—	—	—	—	
72	19.44	0.008	L	MLLM	1759	409	202	—	—	—	—	
73	19.44	1.544	L	MLLH	—	2779	1362	335	83	—	—	
74	19.44	2.048	L	MLML	—	3348	1638	402	100	—	—	
75	19.44	8.192	L	MLMM	—	3348	1638	402	100	—	—	
76	19.44	19.44	L	MLMH	—	—	7706	1832	452	225	112	
77	19.44	25	L	MLHL	—	2778	1362	335	83	—	—	
78	19.44	32.768	L	MLHM	—	—	5022	1215	301	150	75	
79	19.44	34.368	M	MLLM	—	5662	2749	672	167	83	—	
80	19.44	38.88	M	MLLH	—	—	7703	1832	452	225	112	
81	19.44	44.736	M	MLML	—	5653	2747	672	167	83	—	
82	19.44	51.84	M	MLMM	—	—	7696	1832	452	225	112	
83	19.44	65.536	M	MLMH	2618	607	300	74	—	—	—	
84	19.44	77.76	M	MLHL	—	—	7696	1832	452	225	112	
85	19.44	125	M	MLHM	3960	913	450	111	—	—	—	
86	19.44	155.52	H	LMHL	—	—	7696	1832	452	225	112	
87	19.44	156.25	H	LMHM	6003	1373	677	167	—	—	—	

Notes:

1. F_{IN} and F_{OUT} frequency values may be rounded off. For exact multiplication ratios, please contact Silicon Labs.
2. Si5315A supports all frequency plans.
3. Si5315B supports output frequency plans up to 125 MHz.

Table 7. Look Up Tables for Clock Multiplication and Loop Bandwidth Settings (Continued)

Plan #	f _{IN} (MHz)	f _{OUT} (MHz)	FRQTBL	FRQSEL [3:0]	Loop Bandwidth Selection (Hz), BWSEL[1:0]								
					LM	LH	ML	MM	MH	HL	HH		
88	19.44	161.1328	H	LMHH	484	113	—	—	—	—	—	—	—
89	19.44	311.04	H	LHLL	—	—	7696	1832	452	225	—	—	112
90	19.44	312.5	H	LHLM	6003	1373	677	167	—	—	—	—	—
91	19.44	622.08	H	LHLH	—	—	7696	1832	452	225	—	—	112
92	19.44	644.5313	H	LHML	103	—	—	—	—	—	—	—	—
93	25	0.008	L	MLHH	—	—	7045	1681	415	207	—	—	103
94	25	1.544	L	MMLL	6741	1529	753	186	—	—	—	—	—
95	25	2.048	L	MMLM	1299	303	150	—	—	—	—	—	—
96	25	8.192	L	MMLH	6737	1529	753	186	—	—	—	—	—
97	25	19.44	L	MMML	—	—	6551	1568	387	193	—	—	96
98	25	25	L	MMMM	—	—	7615	1812	447	223	—	—	111
99	25	32.768	L	MMMH	6737	1529	753	186	—	—	—	—	—
100	25	34.368	M	MLHH	6722	1528	753	186	—	—	—	—	—
101	25	38.88	M	MMLL	6729	1529	753	186	—	—	—	—	—
102	25	44.736	M	MMLM	1298	303	150	—	—	—	—	—	—
103	25	51.84	M	MMLH	—	7988	3846	936	232	116	—	—	—
104	25	65.536	M	MMML	1298	303	150	—	—	—	—	—	—
105	25	77.76	M	MMMM	6706	1528	753	186	—	—	—	—	—
106	25	125	M	MMMH	—	—	7606	1811	447	223	—	—	111
107	25	155.52	H	LHMM	1298	303	150	—	—	—	—	—	—
108	25	156.25	H	LHMH	—	—	7606	1811	447	223	—	—	111
109	25	161.1328	H	LHHL	—	—	6106	1468	363	181	—	—	90

Notes:

1. F_{IN} and F_{OUT} frequency values may be rounded off. For exact multiplication ratios, please contact Silicon Labs.
2. Si5315A supports all frequency plans.
3. Si5315B supports output frequency plans up to 125 MHz.

Table 7. Look Up Tables for Clock Multiplication and Loop Bandwidth Settings (Continued)

Plan #	f _{IN} (MHz)	f _{OUT} (MHz)	FRQTBL	FRQSEL [3:0]	Loop Bandwidth Selection (Hz), BWSEL[1:0]							
					LM	LH	ML	MM	MH	HL	HH	
110	25	311.04	H	LHHM	1298	303	150	—	—	—	—	—
111	25	312.5	H	LHHH	—	—	7606	1811	447	223	111	—
112	25	622.08	H	MLLL	1298	303	150	—	—	—	—	—
113	25	644.5313	H	MLLM	—	—	6106	1468	363	181	90	—
114	32.768	0.008	L	MMHL	2089	485	240	59	—	—	—	—
115	32.768	1.544	L	MMHM	1037	242	119	—	—	—	—	—
116	32.768	2.048	L	MMHH	—	—	7187	1714	423	211	105	—
117	32.768	8.192	L	MHLL	—	—	7632	1816	448	223	111	—
118	32.768	19.44	L	MHLM	—	—	3946	958	238	118	59	—
119	32.768	25	L	MHLH	2087	485	240	—	—	—	—	—
120	32.768	32.768	L	MHML	—	—	7632	1816	448	223	111	—
121	32.768	34.368	M	MMHL	—	8163	3935	958	238	118	—	—
122	32.768	38.88	M	MMHM	—	—	—	958	238	118	59	—
123	32.768	44.736	M	MMHH	—	3983	1944	477	118	59	—	—
124	32.768	51.84	M	MHLL	—	—	3946	958	238	118	59	—
125	32.768	65.536	M	MHLM	—	—	7604	1815	448	223	111	—
126	32.768	77.76	M	MHLH	—	—	3946	958	238	118	59	—
127	32.768	125	M	MHML	1037	242	119	—	—	—	—	—
128	77.76	0.008	L	MHMM	2089	485	240	59	—	—	—	—
129	77.76	1.544	L	MHMH	—	2779	1362	335	83	—	—	—
130	77.76	2.048	L	MHHL	—	—	6804	1626	402	200	100	—
131	77.76	19.44	L	MHHM	—	—	7905	1879	464	231	115	—

Notes:

1. F_{IN} and F_{OUT} frequency values may be rounded off. For exact multiplication ratios, please contact Silicon Labs.
2. Si5315A supports all frequency plans.
3. Si5315B supports output frequency plans up to 125 MHz.

Table 7. Look Up Tables for Clock Multiplication and Loop Bandwidth Settings (Continued)

Plan #	f _{IN} (MHz)	f _{OUT} (MHz)	FRQTBL	FRQSEL [3:0]	Loop Bandwidth Selection (Hz), BWSEL[1:0]							
					LM	LH	ML	MM	MH	HL	HH	
132	77.76	25	L	MHHH	—	2778	1362	335	83	—	—	—
133	77.76	34.368	M	MHMM	—	—	6798	1626	402	200	100	100
134	77.76	38.88	M	MHMH	—	—	7905	1879	464	231	115	115
135	77.76	44.736	M	MHHL	—	—	6756	1623	402	200	100	100
136	77.76	51.84	M	MHHM	—	—	7905	1879	464	231	115	115
137	77.76	65.536	M	MHHH	—	2461	1208	298	74	—	—	—
138	77.76	77.76	M	HLLL	—	—	7905	1879	464	231	115	115
139	77.76	125	M	HLLM	5336	1220	602	148	—	—	—	—
140	77.76	155.52	H	MLLH	—	—	7905	1879	464	231	115	115
141	77.76	156.25	H	MLML	6003	1373	677	167	—	—	—	—
142	77.76	161.1328	H	MLMM	484	113	—	—	—	—	—	—
143	77.76	311.04	H	MLMH	—	—	7905	1879	464	231	115	115
144	77.76	312.5	H	MLHL	6003	1373	677	167	—	—	—	—
145	77.76	622.08	H	MLHM	—	—	7905	1879	464	231	115	115
146	77.76	644.5313	H	MLHH	484	113	—	—	—	—	—	—
147	125	0.008	L	HLLL	—	—	7045	1681	415	207	103	103
148	125	1.544	L	HLLM	6741	1529	753	186	—	—	—	—
149	125	2.048	L	HLLH	1299	303	150	—	—	—	—	—
150	125	19.44	L	HLML	—	—	6551	1568	387	193	96	96
151	125	25	L	HLMM	—	—	7862	1870	462	230	115	115
152	125	34.368	M	HLLH	6722	1528	753	186	—	—	—	—
153	125	38.88	M	HLML	6729	1529	753	186	—	—	—	—

Notes:

1. F_{IN} and F_{OUT} frequency values may be rounded off. For exact multiplication ratios, please contact Silicon Labs.
2. Si5315A supports all frequency plans.
3. Si5315B supports output frequency plans up to 125 MHz.

Table 7. Look Up Tables for Clock Multiplication and Loop Bandwidth Settings (Continued)

Plan #	f _{IN} (MHz)	f _{OUT} (MHz)	FRQTBL	FRQSEL [3:0]	Loop Bandwidth Selection (Hz), BWSEL[1:0]							
					LM	LH	ML	MM	MH	HL	HH	
154	125	44.736	M	HLMM	1298	303	150	—	—	—	—	—
155	125	51.84	M	HLMH	—	7988	3846	936	232	116	—	—
156	125	65.536	M	HLHL	1298	303	150	—	—	—	—	—
157	125	77.76	M	HLHM	6706	1528	753	186	—	—	—	—
158	125	125	M	HLHH	—	—	7862	1870	462	230	230	115
159	125	155.52	H	MMLL	1298	303	150	—	—	—	—	—
160	125	156.25	H	MMLM	—	—	7862	1870	462	230	230	115
161	125	161.1328	H	MMLH	—	—	7718	1839	454	226	226	113
162	125	311.04	H	MMML	1298	303	150	—	—	—	—	—
163	125	312.5	H	MMMM	—	—	7862	1870	462	230	230	115
164	125	622.08	H	MMMH	1298	303	150	—	—	—	—	—
165	125	644.5313	H	MMHL	—	—	7718	1839	454	226	226	113
166	155.52	0.008	L	HLMH	2089	485	240	59	—	—	—	—
167	155.52	1.544	L	HLHL	—	2779	1362	335	83	—	—	—
168	155.52	2.048	L	HLHM	—	—	7606	1809	447	223	223	111
169	155.52	19.44	L	HLHH	—	—	7905	1879	464	231	231	115
170	155.52	25	L	HMLL	—	2778	1362	335	83	—	—	—
171	155.52	77.76	H	MMHM	—	—	7905	1879	464	231	231	115
172	155.52	125	H	MMHH	5336	1220	602	148	—	—	—	—
173	155.52	155.52	H	MHLL	—	—	7905	1879	464	231	231	115
174	155.52	156.25	H	MHLM	6003	1373	677	167	—	—	—	—
175	155.52	161.1328	H	MHLH	484	113	—	—	—	—	—	—

Notes:

1. F_{IN} and F_{OUT} frequency values may be rounded off. For exact multiplication ratios, please contact Silicon Labs.
2. Si5315A supports all frequency plans.
3. Si5315B supports output frequency plans up to 125 MHz.

Table 7. Look Up Tables for Clock Multiplication and Loop Bandwidth Settings (Continued)

Plan #	f _{IN} (MHz)	f _{OUT} (MHz)	FRQTBL	FRQSEL [3:0]	Loop Bandwidth Selection (Hz), BWSEL[1:0]							
					LM	LH	ML	MM	MH	HL	HH	
176	155.52	311.04	H	MHML	—	—	7905	1879	464	231	115	
177	155.52	312.5	H	MHMM	6003	1373	677	167	—	—	—	
178	155.52	622.08	H	MHMH	—	—	7905	1879	464	231	115	
179	155.52	644.5313	H	MHHL	828	193	95	—	—	—	—	
180	156.25	0.008	L	HMLM	—	—	6123	1469	363	181	90	
181	156.25	1.544	L	HMLH	1627	379	187	—	—	—	—	
182	156.25	2.048	L	HMML	322	75	—	—	—	—	—	
183	156.25	19.44	L	HMMM	—	—	4852	1172	290	145	72	
184	156.25	25	L	HMMH	—	—	7835	1864	460	229	114	
185	156.25	77.76	H	MHHM	1625	379	187	—	—	—	—	
186	156.25	125	H	MHHH	—	—	7835	1864	460	229	114	
187	156.25	155.52	H	HLLL	322	75	—	—	—	—	—	
188	156.25	156.25	H	HLLM	—	—	7835	1864	460	229	114	
189	156.25	161.1328	H	HLLH	—	—	7718	1839	454	226	113	
190	156.25	311.04	H	HLML	322	75	—	—	—	—	—	
191	156.25	312.5	H	HLMM	—	—	7835	1864	460	229	114	
192	156.25	622.08	H	HLMH	322	75	—	—	—	—	—	
193	156.25	644.5313	H	HLHL	—	—	7718	1839	454	226	113	
194	161.1328	0.008	L	HMHL	225	—	—	—	—	—	—	
195	161.1328	1.544	L	HMHM	151	—	—	—	—	—	—	
196	161.1328	2.048	L	HMHH	225	—	—	—	—	—	—	
197	161.1328	19.44	L	HHLL	679	159	78	—	—	—	—	

Notes:

1. F_{IN} and F_{OUT} frequency values may be rounded off. For exact multiplication ratios, please contact Silicon Labs.
2. Si5315A supports all frequency plans.
3. Si5315B supports output frequency plans up to 125 MHz.

Table 7. Look Up Tables for Clock Multiplication and Loop Bandwidth Settings (Continued)

Plan #	f _{IN} (MHz)	f _{OUT} (MHz)	FRQTBL	FRQSEL [3:0]	Loop Bandwidth Selection (Hz), BWSEL[1:0]							
					LM	LH	ML	MM	MH	HL	HH	
198	161.1328	25	L	HHLM	678	159	78	—	—	—	—	—
199	161.1328	77.76	H	HLHM	678	159	78	—	—	—	—	—
200	161.1328	125	H	HLHH	—	—	7179	1721	426	212	106	106
201	161.1328	156.25	H	HMLL	—	—	7019	1683	416	207	103	103
202	161.1328	161.1328	H	HMLM	332	78	—	—	—	—	—	—
204	161.1328	312.5	H	HMML	3873	892	440	109	—	—	—	—
205	161.1328	644.5313	H	HMMM	151	—	—	—	—	—	—	—
206	644.5313	0.008	L	HHLH	880	206	101	—	—	—	—	—
207	644.5313	1.544	L	HHML	413	96	—	—	—	—	—	—
208	644.5313	2.048	L	HHMM	—	3373	1650	405	101	—	—	—
209	644.5313	19.44	L	HMHM	—	3641	1779	437	108	—	—	—
210	644.5313	25	L	HHHL	—	—	7886	1875	463	231	115	115
211	644.5313	77.76	H	HMMH	828	193	95	—	—	—	—	—
212	644.5313	125	H	HMHL	—	—	7732	1840	454	226	113	113
213	644.5313	155.52	H	HMHM	828	193	95	—	—	—	—	—
214	644.5313	156.25	H	HMHM	—	—	7732	1840	454	226	113	113
215	644.5313	161.1328	H	HHLH	—	—	7895	1880	464	231	115	115
216	644.5313	311.04	H	HHLM	828	193	95	—	—	—	—	—
217	644.5313	312.5	H	HHLH	206	—	—	—	—	—	—	—
218	644.5313	622.08	H	HHML	120	—	—	—	—	—	—	—
219	644.5313	644.5313	H	HMMM	—	—	7895	1880	464	231	115	115

Notes:

1. F_{IN} and F_{OUT} frequency values may be rounded off. For exact multiplication ratios, please contact Silicon Labs.
2. Si5315A supports all frequency plans.
3. Si5315B supports output frequency plans up to 125 MHz.

4.2. PLL Self-Calibration

An internal self-calibration (ICAL) is performed before operation to optimize loop parameters and jitter performance. While the self-calibration is being performed, the DSPLL is being internally controlled by the self-calibration state machine. The LOL alarm will be active during ICAL. The self-calibration time t_{LOCKHW} is given in Table 3, "AC Characteristics".

Any of the following events will trigger a self-calibration:

- Power-on-reset (POR)
- Release of the external reset pin \overline{RST} (transition of \overline{RST} from 0 to 1)
- Change in FRQSEL, FRQTBL, BWSEL, or XTAL/CLOCK pins
- Internal DSPLL registers out-of-range, indicating the need to relock the DSPLL

In any of the above cases, an internal self-calibration will be initiated if a valid input clock exists (no input alarm) and is selected as the active clock at that time. The external crystal or reference clock must also be present for the self-calibration to begin. If valid clocks are not present, the self-calibration state machine will wait until they appear, at which time the calibration will start. An output clock will be active while waiting for a valid input clock. The output clock frequency is based on the VCO range determined by FRQSEL and FRQTBL settings. This output clock will vary by +/-20%. If no output clock is desired prior to an ICAL, then the appropriate SFOUT setting is required.

After a successful self-calibration has been performed with a valid input clock, no subsequent self-calibrations are performed unless one of the above conditions are met. If the input clock is lost following self-calibration, the device enters holdover mode. When the input clock returns, the device relocks to the input clock without performing a self-calibration.

4.2.1. Input Clock Stability during Internal Self-Calibration

An exit from reset must occur when the selected CKINn clock is stable in frequency with a frequency value that is within the device operating range. The other CKINs must also either be stable in frequency or squelched during a reset.

4.2.2. Self-Calibration caused by Changes in Input Frequency

If the selected CKINn varies by 500 ppm or more in frequency since the last calibration, the device may initiate a self-calibration.

4.2.3. Device Reset

Upon powerup, the device internally executes a power-on-reset (POR) which resets the internal device logic. The pin \overline{RST} can also be used to initiate a reset. The device stays in this state until a valid CKINn is present, when it then performs a PLL Self-Calibration (See 4.2. "PLL Self-Calibration").

4.2.4. Recommended Reset Guidelines

Follow the recommended RESET guidelines in Table 8 when reset should be applied to a device.

Table 8. Si5315 Pins and Reset

Pin #	Si5315 Pin Name	Must Reset after Changing
2	FRQTBL	Yes
11	XTAL/CLOCK	Yes
22	BWSEL0	Yes
23	BWSEL1	Yes
24	FRQSEL0	Yes
25	FRQSEL1	Yes
26	FRQSEL2	Yes
27	FRQSEL3	Yes

4.2.5. Hitless Switching with Phase Build-Out

Silicon Laboratories switching technology performs "phase build-out" to minimize the propagation of phase transients to the clock outputs during input clock switching. All switching between input clocks occurs within the input multiplexor and phase detector circuitry. The phase detector circuitry continually monitors the phase difference between each input clock and the DSPLL output clock, f_{OSC} . The phase detector circuitry can lock to a clock signal at a specified phase offset relative to f_{OSC} so that the phase offset is maintained by the PLL circuitry.

At the time a clock switch occurs, the phase detector circuitry knows both the input-to-output phase relationship for the original input clock and for the new input clock. The phase detector circuitry locks to the new input clock at the new clock's phase offset so that the phase of the output clock is not disturbed. The phase difference between the two input clocks is absorbed in the phase detector's offset value, rather than being propagated to the clock output.

The switching technology virtually eliminates the output clock phase transients traditionally associated with clock rearrangement (input clock switching). The Maximum Time Interval Error (MTIE) and maximum slope for clock output phase transients during clock switching are given in (Table 3, "AC Characteristics"). These values fall significantly below the limits specified in the ITU-T G.8262, Telcordia GR-1244-CORE, and GR-253-CORE requirements.

4.3. Input Clock Control

This section describes the clock selection capabilities (manual input selection, automatic input selection, hitless switching, and revertive switching). When switching between two clocks, LOL may temporarily go high if the two clocks differ in frequency by more than 100 ppm.

4.3.1. Manual Clock Selection

Manual control of input clock selection is chosen via the CS_CA pin according to Table 9 and Table 10.

Table 9. Automatic/Manual Clock Selection

AUTOSEL	Clock Selection Mode
L	Manual
M	Automatic non-revertive
H	Automatic revertive

Table 10. Manual Input Clock Selection, AUTOSEL = L

CS_CA	Si5315 AUTOSEL = L
0	CKIN1
1	CKIN2

4.3.2. Automatic Clock Selection

The AUTOSEL input pin sets the input clock selection mode as shown in Table 9. Automatic switching is either revertive or non-revertive. Setting AUTOSEL to M or H, changes the CS_CA pin to an output pin that indicates the state of the automatic clock selection.

Table 11. Clock Active Indicators, AUTOSEL = M or H

CS_CA	Active Clock
0	CKIN1
1	CKIN2

The prioritization of clock inputs for automatic switching is shown in Table 12. This priority is hardwired in the devices.

Table 12. Input Clock Priority for Auto Switching

Priority	Input Clocks
1	CKIN1
2	CKIN2
3	Holdover

At power-on or reset, the valid CKINn with the highest priority (1 being the highest priority) is automatically selected. If no valid CKINn is available, the device suppresses the output clocks and waits for a valid CKINn signal. If the currently selected CKINn goes into an alarm state, the next valid CKINn in priority order is selected. If no valid CKINn is available, the device enters holdover.

Operation in revertive and non-revertive is different when a signal becomes valid:

Revertive (AUTOSEL = H): The device constantly monitors all CKINn. If a CKINn with a higher priority than the current active CKINn becomes valid, the active CKINn is changed to the CKINn with the highest priority.

Non-revertive (AUTOSEL = M): The active clock does not change until there is an alarm on the active clock. The device will then select the highest priority CKINn that is valid. Once in holdover, the device will switch to the first CKINn that becomes valid.

4.4. Alarms

Summary alarms are available to indicate the overall status of the input signals. Alarm outputs stay high until all the alarm conditions for that alarm output are cleared.

4.4.1. Loss-of-Signal

The device has loss-of-signal circuitry that continuously monitors CKINn for missing pulses. The LOS circuitry generates an internal LOSn_INT output signal that is processed with other alarms to generate LOS1 and LOS2.

An LOS condition on CKIN1 causes the internal LOS1_INT alarm to become active. Similarly, an LOS condition on CKINn causes the LOSn_INT alarm to become active. Once a LOSn_INT alarm is asserted on one of the input clocks, it remains asserted until that input clock is validated over a designated time period. The time to clear LOSn_INT after a valid input clock appears is listed in Table 3, “AC Characteristics”. If another error condition on the same input clock is detected during the validation time then the alarm remains asserted and the validation time starts over.

4.4.1.1. LOS Algorithm

The LOS circuitry divides down each input clock to produce an 8 kHz to 2 MHz signal. The LOS circuitry over samples this divided down input clock using a 40 MHz clock to search for extended periods of time without input clock transitions. If the LOS monitor detects twice the normal number of samples without a clock edge, a LOSn_INT alarm is declared. Table 3, “AC Characteristics” gives the minimum and maximum amount of time for the LOS monitor to trigger.

4.4.1.2. Lock Detect

The PLL lock detection algorithm indicates the lock status on the LOL output pin. The algorithm works by continuously monitoring the phase of the input clock in relation to the phase of the feedback clock. If the time between two consecutive phase cycle slips is greater than the retrigger time, the PLL is in lock. The LOL output has a guaranteed minimum pulse width as shown in (Table 3, “AC Characteristics”). The LOL pin is also held in the active state during an internal PLL calibration. The retrigger time is automatically set based on the PLL closed loop bandwidth (See Table 13).

Table 13. Lock Detect Retrigger Time

PLL Bandwidth Setting (BW)	Retrigger Time (ms)
60–120 Hz	53
120–240 Hz	26.5
240–480 Hz	13.3
480–960 Hz	6.6
960–1920 Hz	3.3
1920–3840 Hz	1.66
3840–7680 Hz	0.833

4.5. Holdover Mode

If an LOS condition exists on the selected input clock, the device enters holdover. In this mode, the device provides a stable output frequency until the input clock returns and is validated. When the device enters holdover, the internal oscillator is initially held to its last frequency value. Next, the internal oscillator slowly transitions to a historical average frequency value that was taken over a time window of 6,711 ms in size that ended 26 ms before the device entered holdover. This frequency value is taken from an internal memory location that keeps a record of previous DSPLL frequency values. By using a historical average frequency, input clock phase and frequency transients that may occur immediately preceding loss of clock or any event causing holdover do not affect the holdover frequency. Also, noise related to input clock jitter or internal PLL jitter is minimized.

If a highly stable reference, such as an oven-controlled crystal oscillator, is supplied at XA/XB, an extremely stable holdover can be achieved. If a crystal is supplied at the XA/XB port, the holdover stability will be limited by the stability of the crystal; Table 3, "AC Characteristics" gives the specifications related to the holdover function.

4.5.1. Recovery from Holdover

When the input clock signal returns, the device transitions from holdover to the selected input clock. The device performs hitless recovery from holdover. The clock transition from holdover to the returned input clock includes "phase buildout" to absorb the phase difference between the holdover clock phase and the input clock phase. See Table 3, "AC Characteristics" for specifications.

4.6. PLL Bypass Mode

The Si5315 supports a PLL bypass mode in which the selected input clock is fed directly to both enabled output buffers, bypassing the DSPLL. Internally, the bypass path is implemented with high-speed differential signaling; however, this path is not a low jitter path and will see significantly higher jitter on CKOUT. In PLL bypass mode, the input and output clocks will be at the same frequency. PLL bypass mode is useful in a laboratory environment to measure system performance with and without the jitter attenuation provided by the DSPLL. The DSBL2_BY pin is used to select the PLL Bypass Mode according to Table 14.

Table 14. DSBL2/BYPASS Pin Settings

DSBL2/BYPASS	Function
L	CKOUT2 Enabled
M	CKOUT2 Disabled
H	PLL Bypass Mode w/ CKOUT2 Enabled

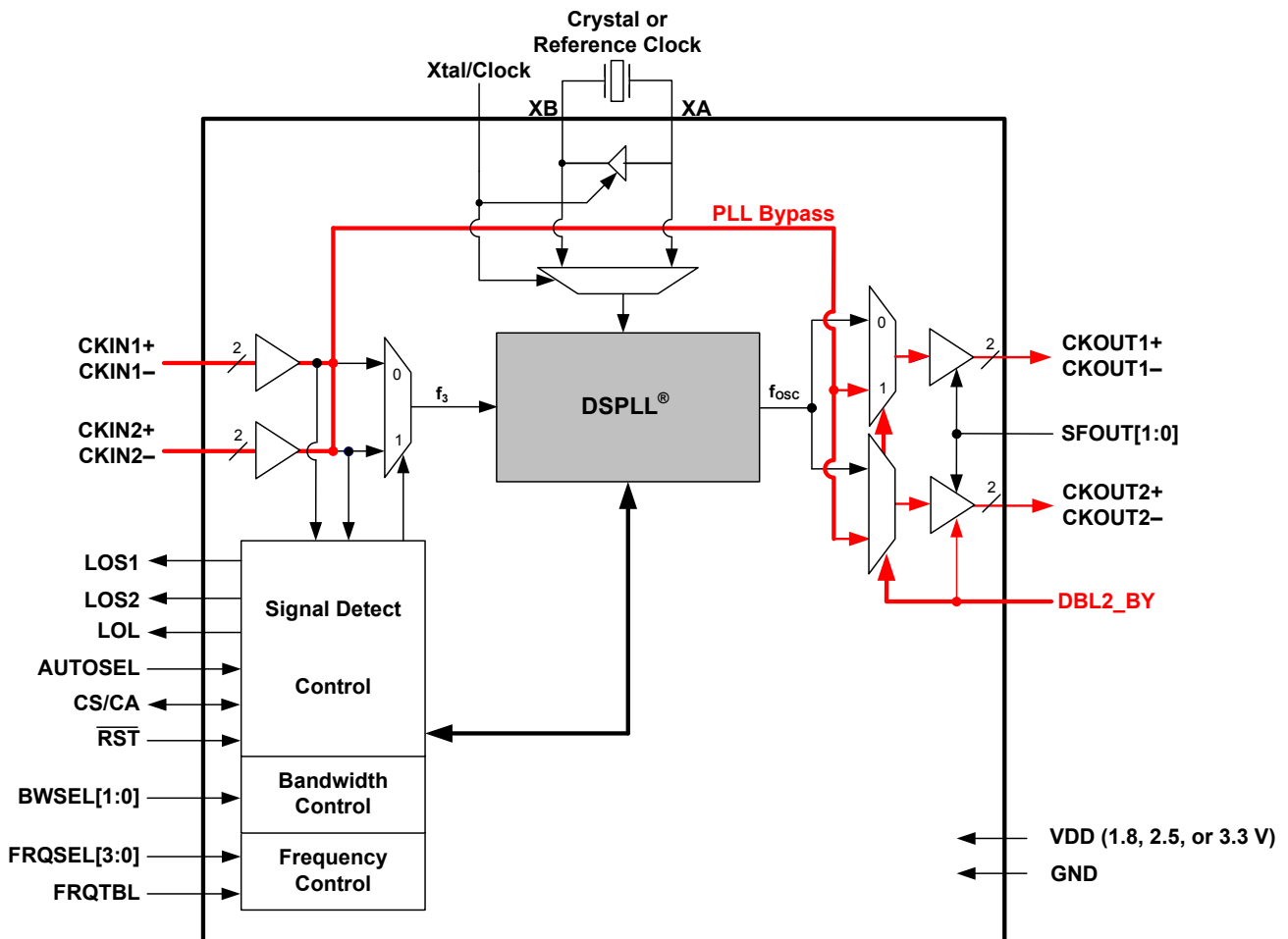

Figure 9. Bypass Signal

5. High-Speed I/O

5.1. Input Clock Buffers

The Si5315 provides differential inputs for the CKINn clock inputs. These inputs are internally biased to a common mode voltage [see Table 2, “DC Characteristics”] and can be driven by either a single-ended or differential source. Figure 10 through Figure 13 show typical interface circuits for LVPECL, CML, LVDS, or CMOS input clocks. Note that the jitter generation improves for higher levels on CKINn (within the limits in Table 3, “AC Characteristics”).

AC coupling the input clocks is recommended because it removes any issue with common mode input voltages. However, either ac or dc coupling is acceptable. Figures 10 and 11 show various examples of different input termination arrangements. Unused inputs can be left unconnected.

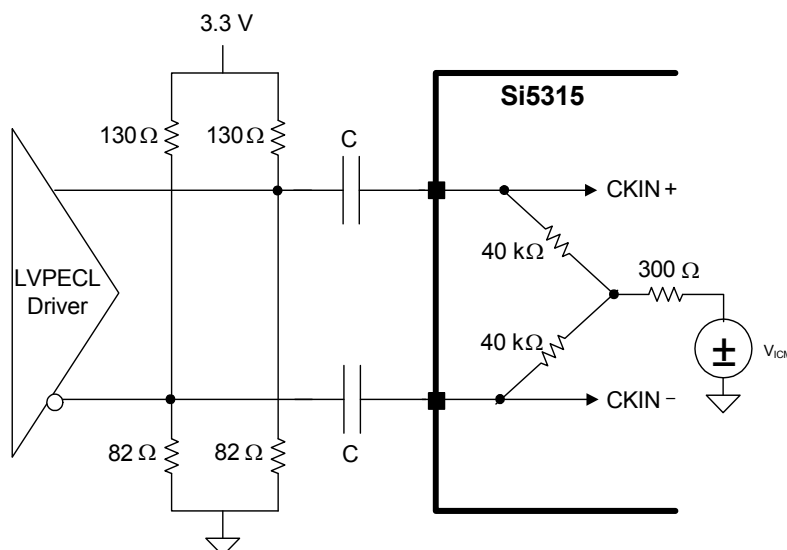

Figure 10. Differential LVPECL Termination

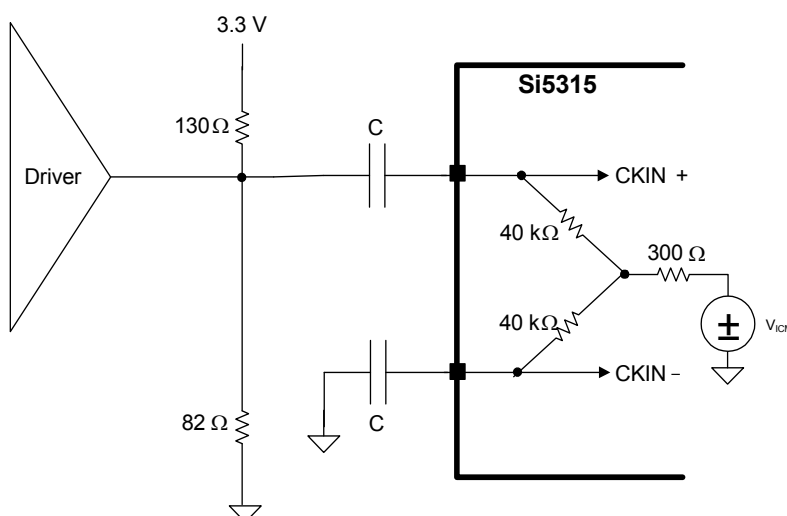

Figure 11. Single-ended LVPECL Termination

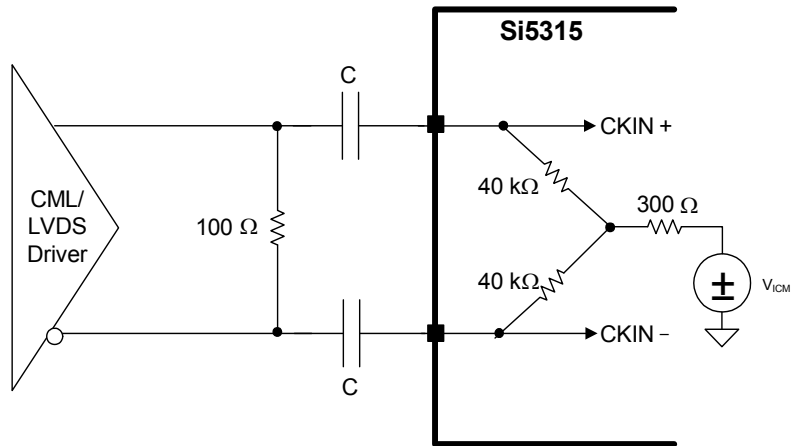

Figure 12. CML/LVDS Termination (1.8, 2.5, 3.3 V)

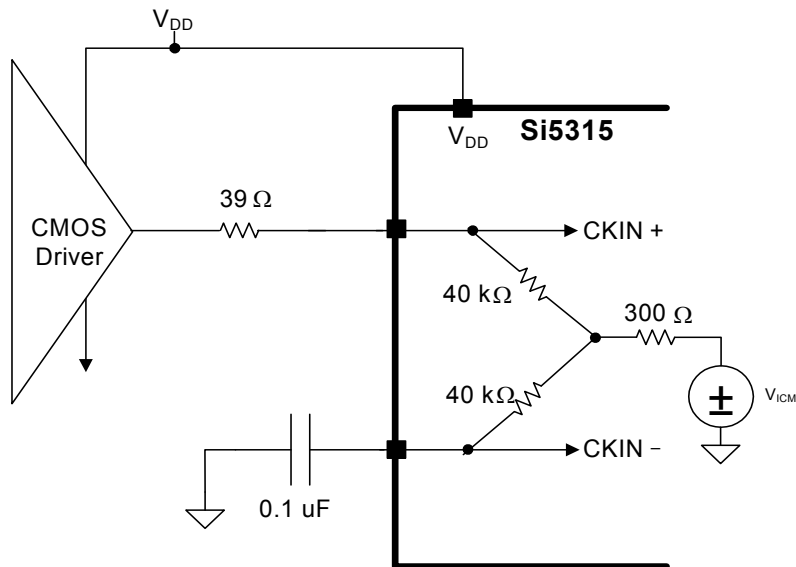

Figure 13. CMOS Termination (1.8, 2.5, 3.3 V)

5.2. Output Clock Drivers

The Si5315 has a flexible output driver structure that can drive a variety of loads, including LVPECL, LVDS, CML, and CMOS formats. The signal format is selected for both CKOUT1 and CKOUT2 outputs using the SFOUT [1:0] pins. This modifies the output common mode and differential signal swing. See Table 2, “DC Characteristics” for output driver specifications. The SFOUT [1:0] pins are three-level input pins, with the states designated as L (ground), M ($V_{DD}/2$), and H (V_{DD}). Table 15 shows the signal formats based on the supply voltage and the type of load being driven.

Table 15. Output Signal Format Selection (SFOUT)

SFOUT[1:0]	Signal Format
HL	CML
HM	LVDS
LH	CMOS
LM	Disabled
MH	LVPECL
ML	Low-swing LVDS
All Others	Reserved

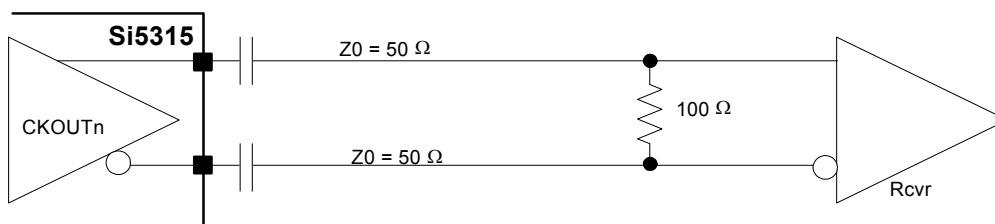

Figure 14. Typical Differential Output Circuit

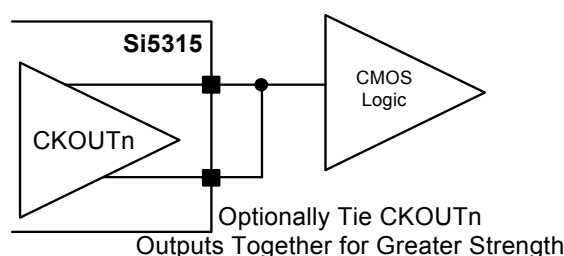

Figure 15. Typical CMOS Output Circuit (Tie CKOUTn+ and CKOUTn- Together)

For the CMOS setting (SFOUT = LH), both output pins drive single-ended in-phase signals. The CKOUT+/- can be externally shorted together for greater drive strength specified in Table 2, “DC Characteristics”.

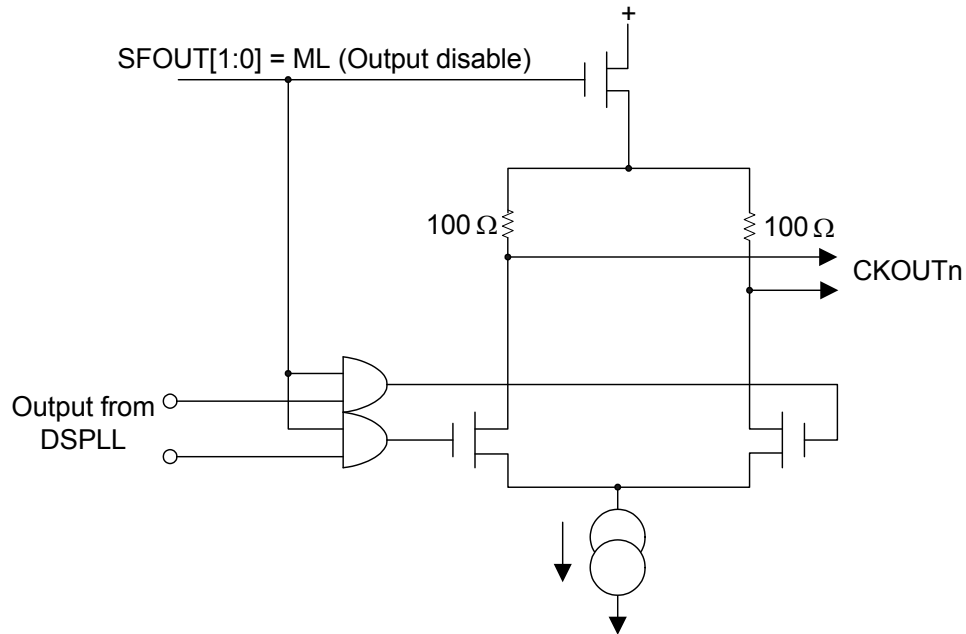
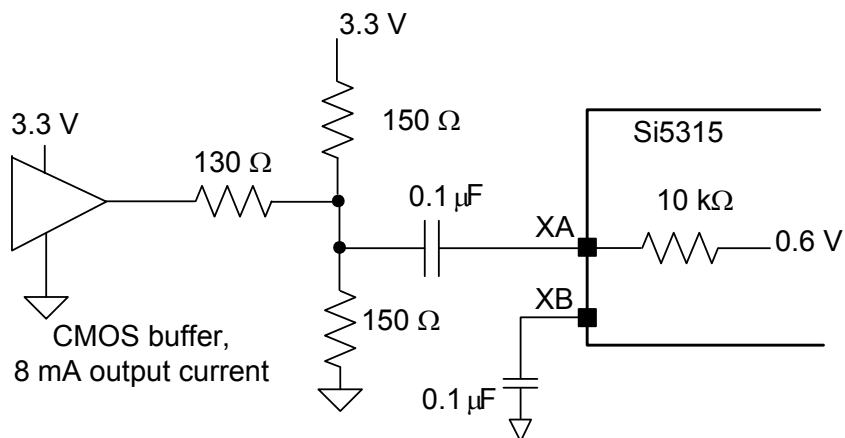

Figure 16. Disable CKOUTn Structure

The SFOUT [1:0] pins can also be used to disable both outputs. Disabling the output puts the CKOUTn+ and CKOUTn- pins in a high-impedance state relative to V_{DD} (common mode tri-state) while the two outputs remain connected to each other through a $200\ \Omega$ on-chip resistance (differential impedance of $200\ \Omega$). The maximum amount of internal circuitry is powered down, minimizing power consumption and noise generation. Recovery from the disable mode requires additional time as specified in Table 3, "AC Characteristics".

6. Crystal/Reference Clock Input

The device can use an external crystal or external clock as a reference. If an external clock is used, it must be ac coupled. With appropriate buffers, the same external reference clock can be applied to CKINn. Although the reference clock input can be driven single ended (See Figure 17), the best performance is with a crystal or low jitter, differential clock source. No external loading capacitors are required for normal crystal operation.



For 2.5 V operation, change 130 Ω to 82 Ω .

Figure 17. CMOS External Reference Circuit

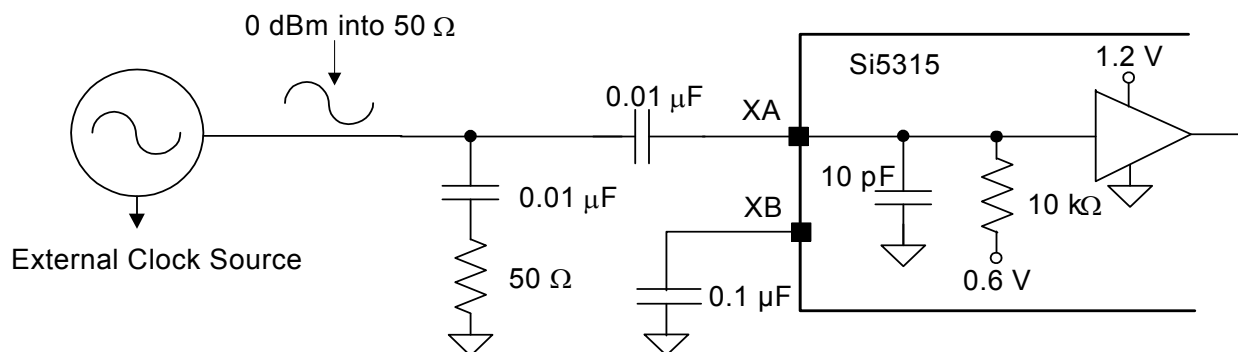

Figure 18. Sinewave External Reference Clock Input Example

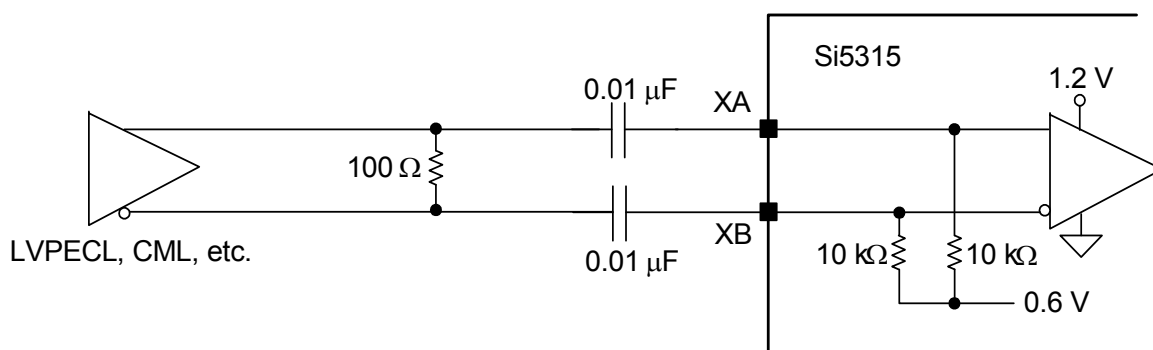

Figure 19. Differential External Reference Clock Input Example

6.1. Crystal/Reference Clock Selection

An external, low jitter 40 MHz clock or a low-cost 40 MHz fundamental mode crystal is used as part of a fixed-frequency oscillator within the DSPLL. This external X-reference on XA/XB is required for the device to perform jitter attenuation. Silicon Laboratories recommends using a high-quality crystal.

In holdover, the DSPLL remains locked to this external reference. Any changes in the frequency of this reference when the DSPLL is in holdover will be tracked by the output of the device. Note that crystals can have temperature sensitivities. Table 16 shows the recommended 40 MHz fundamental mode crystals.

Table 16. Recommended Crystals

Manufacturer	Part Number	Web Site
Abracon Corporation	ABM8-40.000MHZ-B2-T	http://www.abracon.com
Connor Winfield	XL-1CE	http://www.conwin.com
CTS Corporation	403	http://ctscorp.com
ECS Inc., International	ECS-400-20-33-A-S-L-TR	http://ecsxtal.com
Mtron	M1253-3-P-P-40.0000MHZ	http://www.mtronpti.com

Note: While these crystals meet the preceding criteria according to their data sheets, Silicon Laboratories, Inc. does not guarantee operation with the Si5315, nor does Silicon Laboratories endorse one supplier of crystals over another. Contact Silicon Labs for details and a current list of crystal vendors and recommended part numbers.

Table 17. XA/XB Reference Sources

XTAL/CLOCK	Type
M	External clock
L	40 MHz crystal

Because the crystal is used as a jitter reference, rapid changes of the crystal temperature can temporarily disturb the output phase and frequency. For example, it is recommended that the crystal not be placed close to a fan that is being turned off and on. If a situation such as this is unavoidable, the crystal should be thermally isolated with an insulating cover.

6.1.1. Reference Drift

During holdover, long-term and temperature related drift of the reference input result in a one-to-one drift of the output frequency. That is, the stability of the any-rate output is identical to the drift of the reference frequency. This means that for the most demanding applications where the drift of a crystal is not acceptable, an external temperature compensated or ovenized oscillator will be required. Drift is not an issue unless the part is in holdover. Also, the initial accuracy of the reference oscillator (or crystal) is not relevant.

6.1.2. Reference Jitter

Jitter on the reference input has a roughly one-to-one transfer function to the output jitter over the bandwidth ranging from 100 Hz up to 30 kHz. If a crystal is used on the XA/XB pins, the reference will have low jitter if a suitable crystal is in use. If the XA/XB pins are connected to an external reference oscillator, the jitter of the external reference oscillator may contribute significantly to the output jitter.

A typical reference input-to-output jitter transfer function is shown in Figure 20.

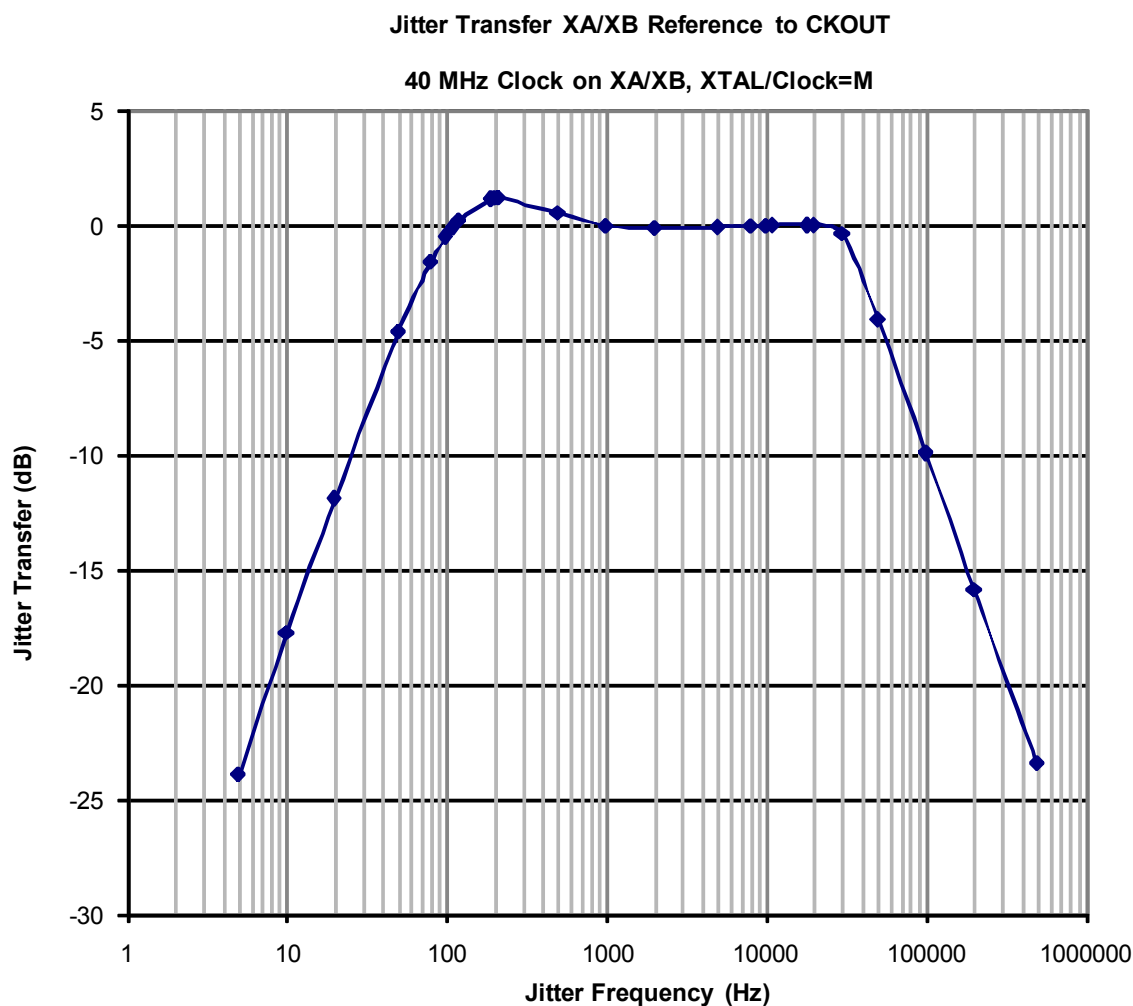

Figure 20. Typical XA/XB Reference Jitter Transfer Function

7. Power Supply Filtering

This device incorporates an on-chip voltage regulator with excellent PSRR to power the device from a supply voltage of 1.8, 2.5, or 3.3 V. The device requires minimal supply decoupling and no stringent layout or ground plane islands. Internal core circuitry is driven from the output of this regulator while I/O circuitry uses the external supply voltage directly. Table 3, "AC Characteristics" gives the sensitivity of the on-chip oscillator to changes in the supply voltage. Refer to the Si5315 evaluation board for an example.

The center ground pad under the device must be electrically and thermally connected to the ground plane. See Figure 26, "Ground Pad Recommended Layout," on page 54.

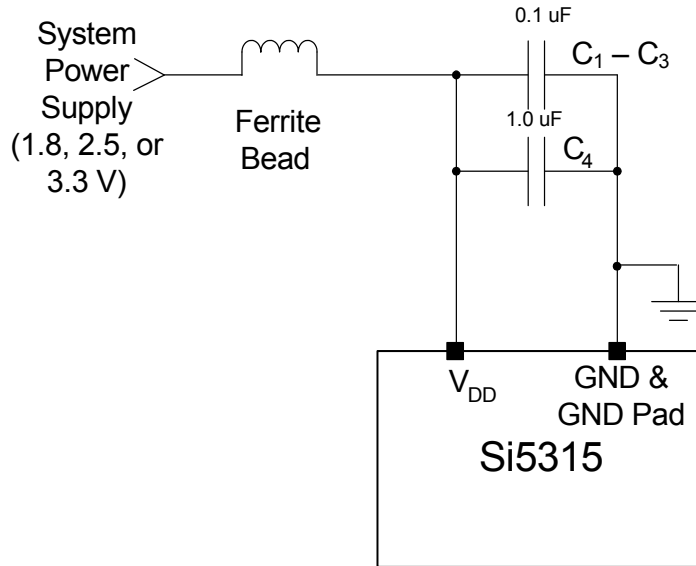

Figure 21. Typical Power Supply Bypass Network

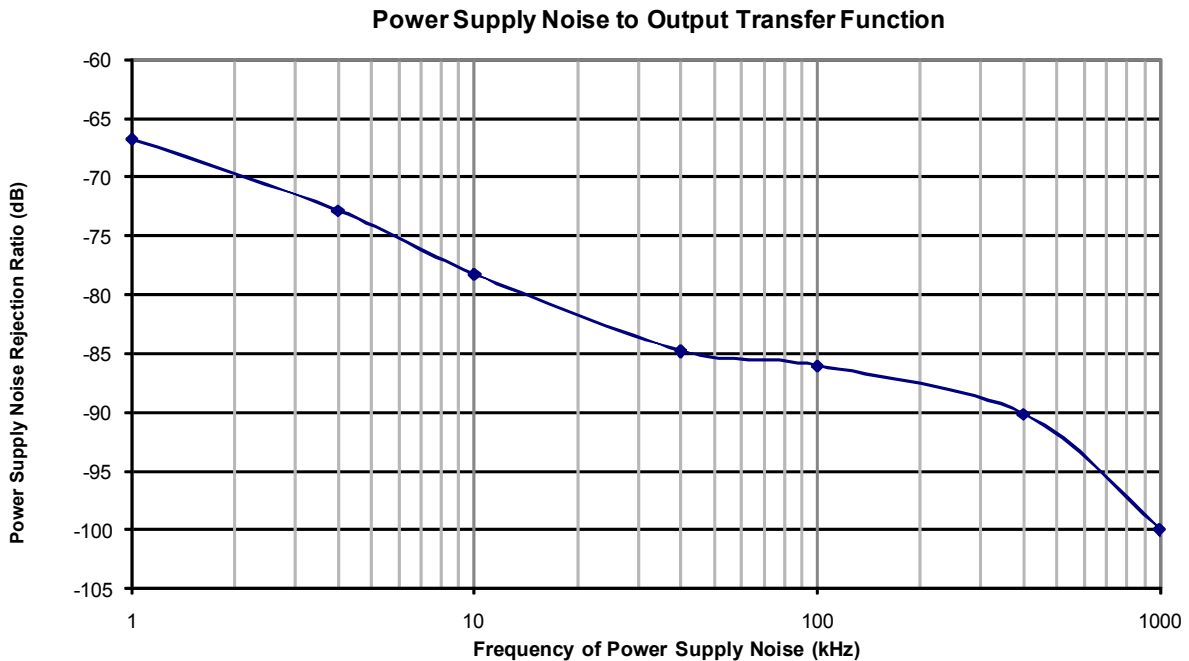
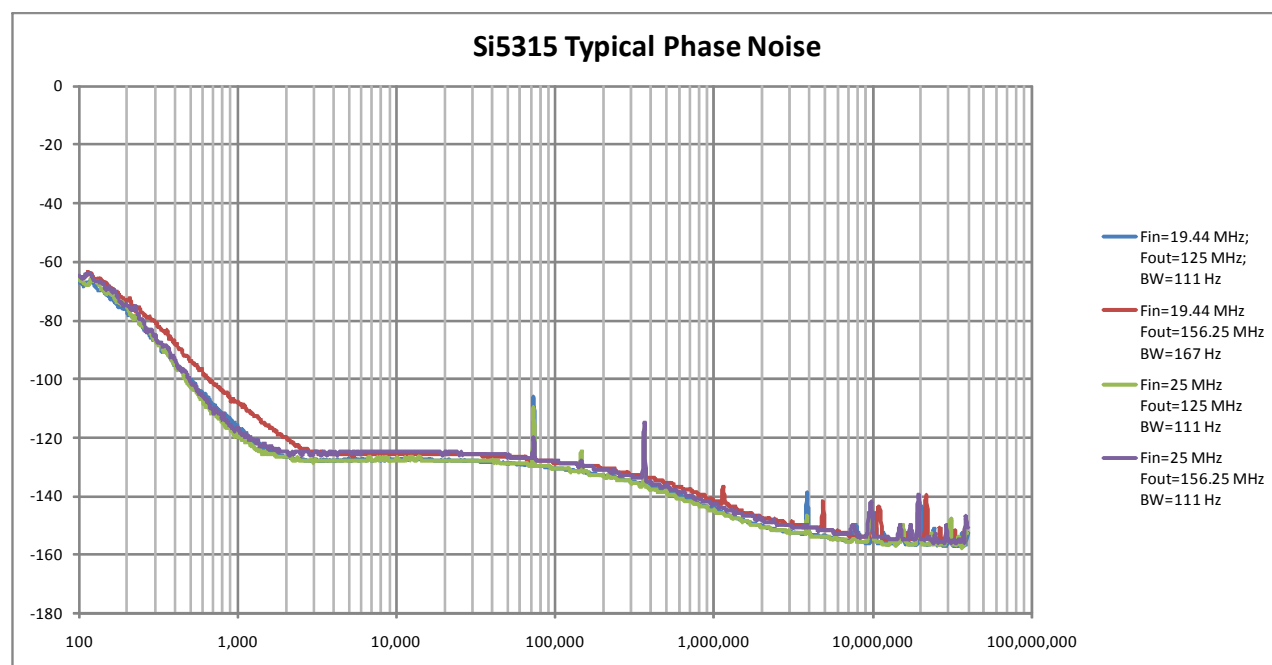

Figure 22. $f_{out} = 155$ MHz with 112 Hz Loop Bandwidth, 100 mVp-p Supply Noise

8. Typical Phase Noise Plots

The following is a typical phase noise plot. The clock input source was a Rohde and Schwarz model SML03 RF Generator. The spectrum analyzer was either an Agilent model E5052B, model E4400A or model JS-500. The Si5315 operates at 3.3 V with an ac coupled differential PECL output and an ac coupled differential sine wave input from the RF generator at 0 dBm. Note that, as with any PLL, the output jitter that is below the loop BW is caused by the jitter at the input clock, not the Si5315. Except as noted, loop BWs of 60 to 240 Hz were in use.

8.1. Example: 10G LAN SyncE



	Frequency Plan			
	$F_{in}=19.44$ MHz $F_{out}=156.25$ MHz BW=167 Hz	$F_{in}=19.44$ MHz $F_{out}=125$ MHz BW=111 Hz	$F_{in}=25$ MHz $F_{out}=156.25$ MHz BW=111 Hz	$F_{in}=25$ MHz $F_{out}=125$ MHz BW=111 Hz
Jitter Integration Filter Band	RMS Jitter (fs)			
IEEE802.3 (1.875 to 20 MHz)	232	240	251	240
SONET OC-192 (20 kHz to 80 MHz)	483	575	525	550
SONET OC-192 (4 to 80 MHz)	302	303	300	294
SONET OC-192 (50 kHz to 80 MHz)	467	564	510	537
SONET OC-48 (12 kHz to 20 MHz)	470	565	517	541
SONET OC-3 (12 kHz to 5 MHz)	422	524	471	503
BroadBand (800 Hz to 80 MHz)	511	584	533	557

9. Typical Application Circuit

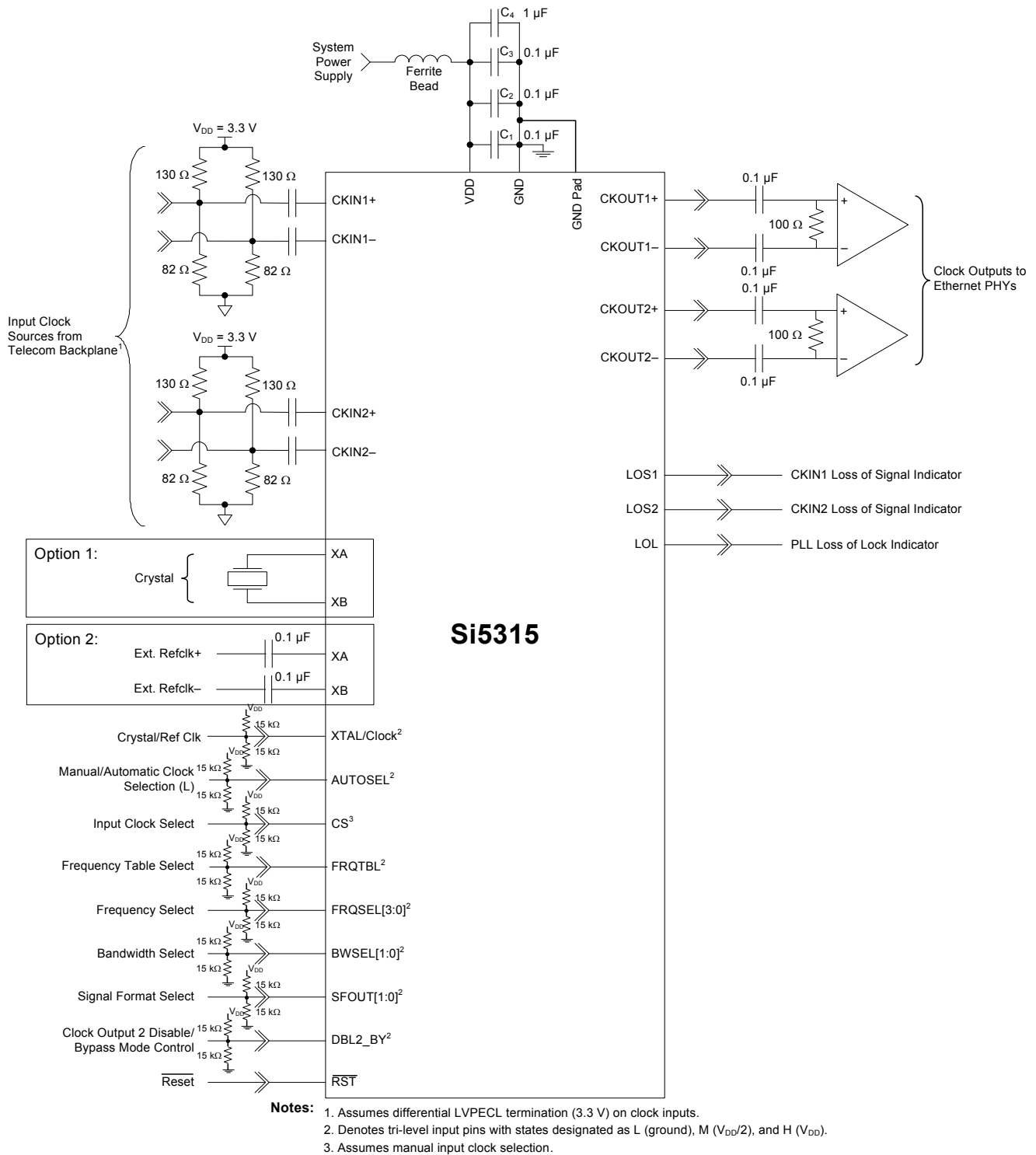
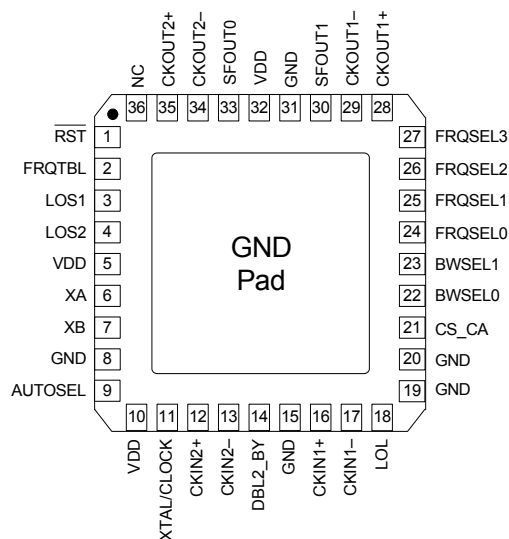

Figure 23. Si5315 Typical Application Circuit

10. Pin Descriptions: Si5315



Pin assignments are preliminary and subject to change.

Table 18. Si5315 Pin Descriptions

Pin #	Pin Name	I/O	Signal Level	Description
1	RST	I	LVC MOS	External Reset. Active low input that performs external hardware reset of device. Resets all internal logic to a known state. Clock outputs are tristated during reset. After rising edge of $\overline{\text{RST}}$ signal, the Si5315 will perform an internal self-calibration when a valid input signal is present. This pin has a weak pull-up.
2	FRQTBL	I	3-Level	Frequency Table Select. Selects frequency table. (Table 7 on page 20.) This pin has a weak pull-up and weak pull-down and defaults to M. Some designs may require an external resistor voltage divider when driven by an active device that will tri-state.
3	LOS1	O	LVC MOS	CKIN1 Loss of Signal. Active high loss-of-signal indicator for CKIN1. Once triggered, the alarm will remain active until CKIN1 is validated. 0 = CKIN1 present 1 = LOS on CKIN1
4	LOS2	O	LVC MOS	CKIN2 Loss of Signal. Active high loss-of-signal indicator for CKIN2. Once triggered, the alarm will remain active until CKIN2 is validated. 0 = CKIN2 present 1 = LOS on CKIN2

Table 18. Si5315 Pin Descriptions (Continued)

Pin #	Pin Name	I/O	Signal Level	Description						
5, 10, 32	V _{DD}	V _{DD}	Supply	<p>Supply.</p> <p>The device operates from a 1.8, 2.5, or 3.3 V supply. Bypass capacitors should be associated with the following V_{DD} pins:</p> <table> <tr> <td>5</td> <td>0.1 μF</td> </tr> <tr> <td>10</td> <td>0.1 μF</td> </tr> <tr> <td>32</td> <td>0.1 μF</td> </tr> </table> <p>A 1.0 μF should also be placed as close to device as is practical.</p>	5	0.1 μF	10	0.1 μF	32	0.1 μF
5	0.1 μF									
10	0.1 μF									
32	0.1 μF									
7 6	XB XA	I	Analog	<p>External Crystal or Reference Clock.</p> <p>External crystal should be connected to these pins to use internal oscillator based reference. Crystal or reference clock selection is set by the XTAL/CLOCK pin.</p>						
8, 15, 19, 20, 31	GND	GND	Supply	<p>Ground.</p> <p>Must be connected to system ground. Minimize the ground path impedance for optimal performance of this device.</p>						
9	AUTOSEL	I	3-Level	<p>Manual/Automatic Clock Selection.</p> <p>Three level input that selects the method of input clock selection to be used.</p> <p>L = Manual M = Automatic non-revertive H = Automatic revertive</p> <p>This pin has a weak pull-up and weak pull-down and defaults to M.</p> <p>Some designs may require an external resistor voltage divider when driven by an active device that will tri-state.</p>						
11	XTAL/CLOCK	I	3-Level	<p>External Crystal or Reference Clock Rate.</p> <p>Three level input that selects the type and rate of external crystal or reference clock to be applied to the XA/XB port. This pin has both a weak pull-up and a weak pull-down and defaults to M.</p> <p>L = Crystal M = Clock (Default) H = Reserved</p> <p>Some designs may require an external resistor voltage divider when driven by an active device that will tri-state.</p>						
12 13	CKIN2+ CKIN2-	I		<p>Clock Input 2.</p> <p>Differential input clock. This input can also be driven with a single-ended signal. Input frequency selected from a table of values. The same frequency must be applied to CKIN1 and CKIN2.</p>						

Table 18. Si5315 Pin Descriptions (Continued)

Pin #	Pin Name	I/O	Signal Level	Description
14	DBL2_BY	I	3-Level	<p>Output 2 Disable/Bypass Mode Control. Controls enable of CKOUT2 divider/output buffer path and PLL bypass mode. L = CKOUT2 enabled M = CKOUT2 disabled H = Bypass mode with CKOUT2 enabled This pin has a weak pull-up and weak pull-down and defaults to M. Some designs may require an external resistor voltage divider when driven by an active device that will tri-state.</p>
16 17	CKIN1+ CKIN1–	I	Multi	<p>Clock Input 1. Differential input clock. This input can also be driven with a single-ended signal. Input frequency selected from a table of values. The same frequency must be applied to CKIN1 and CKIN2.</p>
18	LOL	O	LVC MOS	<p>PLL Loss of Lock Indicator. This pin functions as the active high PLL loss of lock indicator. 0 = PLL locked 1 = PLL unlocked</p>
21	CS_CA	I/O	LVC MOS	<p>Input Clock Select/Active Clock Indicator. Input: If manual clock selection mode is chosen (AUTOSEL = L), this pin functions as the manual input clock selector. This input is internally deglitched to prevent inadvertent clock switching during changes in the CS input state. 0 = Select CKIN1 1 = Select CKIN2 If configured as input, must be set high or low. Output: If automatic clock selection mode is chosen (AUTOSEL = M or H), this pin indicates which of the two input clocks is currently the active clock. If alarms exist on both CKIN1 and CKIN2, indicating that the holdover state has been entered, CA will indicate the last active clock that was used before entering the hold state. 0 = CKIN1 active input clock 1 = CKIN2 active input clock</p>
23 22	BWSEL1 BWSEL0	I	3-Level	<p>Loop Bandwidth Select. Three level inputs that select the DSPLL closed loop bandwidth. See Table 7 on page 20 for available settings. These pins have both weak pull-ups and weak pull-downs and default to M. Some designs may require an external resistor voltage divider when driven by an active device that will tri-state.</p>

Table 18. Si5315 Pin Descriptions (Continued)

Pin #	Pin Name	I/O	Signal Level	Description																				
27 26 25 24	FRQSEL3 FRQSEL2 FRQSEL1 FRQSEL0	I	3-Level	<p>Frequency Select.</p> <p>Three level inputs that select the input clock and clock multiplication ratio, depending on the FRQTBL setting. These pins have both weak pull-ups and weak pull-downs and default to M. Some designs may require an external resistor voltage divider when driven by an active device that will tri-state.</p>																				
29 28	CKOUT1– CKOUT1+	O	Multi	<p>Clock Output 1.</p> <p>Differential output clock with a frequency selected from a table of values. Output signal format is selected by SFOUT pins. Output is differential for LVPECL, LVDS, and CML compatible modes. For CMOS format, both output pins drive identical single-ended clock outputs.</p>																				
33 30	SFOUT0 SFOUT1	I	3-Level	<p>Signal Format Select.</p> <p>Three level inputs that select the output signal format (common mode voltage and differential swing) for both CKOUT1 and CKOUT2.</p> <table border="1" data-bbox="894 848 1385 1297"> <thead> <tr> <th>SFOUT[1:0]</th> <th>Signal Format</th> </tr> </thead> <tbody> <tr> <td>HH</td> <td>Reserved</td> </tr> <tr> <td>HM</td> <td>LVDS</td> </tr> <tr> <td>HL</td> <td>CML</td> </tr> <tr> <td>MH</td> <td>LVPECL</td> </tr> <tr> <td>MM</td> <td>Reserved</td> </tr> <tr> <td>ML</td> <td>LVDS—Low Swing</td> </tr> <tr> <td>LH</td> <td>CMOS</td> </tr> <tr> <td>LM</td> <td>Disable</td> </tr> <tr> <td>LL</td> <td>Reserved</td> </tr> </tbody> </table> <p>These pins have both weak pull-ups and weak pull-downs and default to M. Some designs may require an external resistor voltage divider when driven by an active device that will tri-state.</p>	SFOUT[1:0]	Signal Format	HH	Reserved	HM	LVDS	HL	CML	MH	LVPECL	MM	Reserved	ML	LVDS—Low Swing	LH	CMOS	LM	Disable	LL	Reserved
SFOUT[1:0]	Signal Format																							
HH	Reserved																							
HM	LVDS																							
HL	CML																							
MH	LVPECL																							
MM	Reserved																							
ML	LVDS—Low Swing																							
LH	CMOS																							
LM	Disable																							
LL	Reserved																							
34 35	CKOUT2– CKOUT2+	O	Multi	<p>Clock Output 2.</p> <p>Differential output clock with a frequency selected from a table of values. Output signal format is selected by SFOUT pins. Output is differential for LVPECL, LVDS, and CML compatible modes. For CMOS format, both output pins drive identical single-ended clock outputs.</p>																				
36	NC	—	—	<p>No Connect.</p> <p>Leave floating. Make no external connections to this pin for normal operation.</p>																				
GND PAD	GND	GND	Supply	<p>Ground Pad.</p> <p>The ground pad must provide a low thermal and electrical impedance to a ground plane.</p>																				

Table 19. Si5315 Pull-up/Pull-down

Pin #	Si5315	Pull?
1	$\overline{\text{RST}}$	U
2	FRQTBL	U, D
9	AUTOSEL	U, D
11	XTAL/ CLOCK	U, D
14	DBL2_BY	U, D
21	CS_CA	U, D
22	BWSEL0	U, D
23	BWSEL1	U, D
24	FRQSEL0	U, D
25	FRQSEL1	U, D
26	FRQSEL2	U, D
27	FRQSEL3	U, D
30	SFOUT1	U, D
33	SFOUT0	U, D

11. Ordering Guide

Ordering Part Number	Output Clock Freq Range	Pkg	ROHS6, Pb-Free	Temp Range
Si5315A-C-GM	8 kHz–644.53 MHz	36-Lead 6x6 mm QFN	Yes	–40 to 85 °C
Si5315B-C-GM	8 kHz–125 MHz	36-Lead 6x6 mm QFN	Yes	–40 to 85 °C
Si5315-EVB	8 kHz–644.53 MHz	Evaluation Board		

Note: Add an R at the end of the device to denote tape and reel options (i.e., Si5315A-C-GMR).

Table 20. Any-rate Precision Clock Product Selection Guide

Part Number	Control	Clock Inputs/Outputs	Input Frequency (MHz)	Output Frequency (MHz)	Jitter (12 kHz to 20 MHz)	PLL Bandwidth	Hitless Switching	Digital Hold	Freerun	VCO Freeze	Signal Format	Package
Si5315	Pin	2/2	0.008 to 644	0.008 to 644	470 fs ms typ	60 Hz to 8.4 kHz	✓	✓			CMOS, LVDS, LVPECL, CML	36-QFN
Si5316	Pin	2/1	19 to 710	19 to 710	300 fs ms typ	60 Hz to 8.4 kHz		✓				36-QFN
Si5317	Pin	1/1	1 to 710	1 to 710	300 fs ms typ	60 Hz to 8.4 kHz				✓		36-QFN
Si5319	I ² C or SPI	1/1	0.002 to 710	0.002 to 1417	300 fs ms typ	60 Hz to 8.4 kHz			✓	✓		36-QFN
Si5322	Pin	2/2	19 to 707	19 to 1050	600 fs ms typ	30 kHz to 1.3 MHz				✓		36-QFN
Si5323	Pin	2/2	0.008 to 707	0.008 to 1050	300 fs ms typ	60 Hz to 8.4 kHz	✓	✓				36-QFN
Si5324	I ² C or SPI	2/2	0.002 to 710	0.002 to 1417	290 fs ms typ	4 to 525 Hz	✓	✓	✓			36-QFN
Si5325	I ² C or SPI	2/2	10 to 710	10 to 1417	600 fs ms typ	30 kHz to 1.3 MHz				✓		36-QFN
Si5326	I ² C or SPI	2/2	0.002 to 710	0.002 to 1417	300 fs ms typ	60 Hz to 8.4 kHz	✓	✓	✓			36-QFN
Si5365	Pin	4/5	19 to 710	19 to 1050	600 fs ms typ	30 kHz to 1.3 MHz				✓		100-TQFP
Si5366	Pin	4/5	0.008 to 707	0.008 to 1050	300 fs ms typ	60 Hz to 8.4 kHz	✓	✓				100-TQFP
Si5367	I ² C or SPI	4/5	10 to 710	10 to 1417	600 fs ms typ	30 kHz to 1.3 MHz				✓		100-TQFP
Si5368	I ² C or SPI	4/5	0.002 to 710	0.002 to 1417	300 fs ms typ	60 Hz to 8.4 kHz	✓	✓	✓			100-TQFP

12. Package Outline: 36-Pin QFN

Figure 24 illustrates the package details for the Si5315. Table 21 lists the values for the dimensions shown in the illustration.

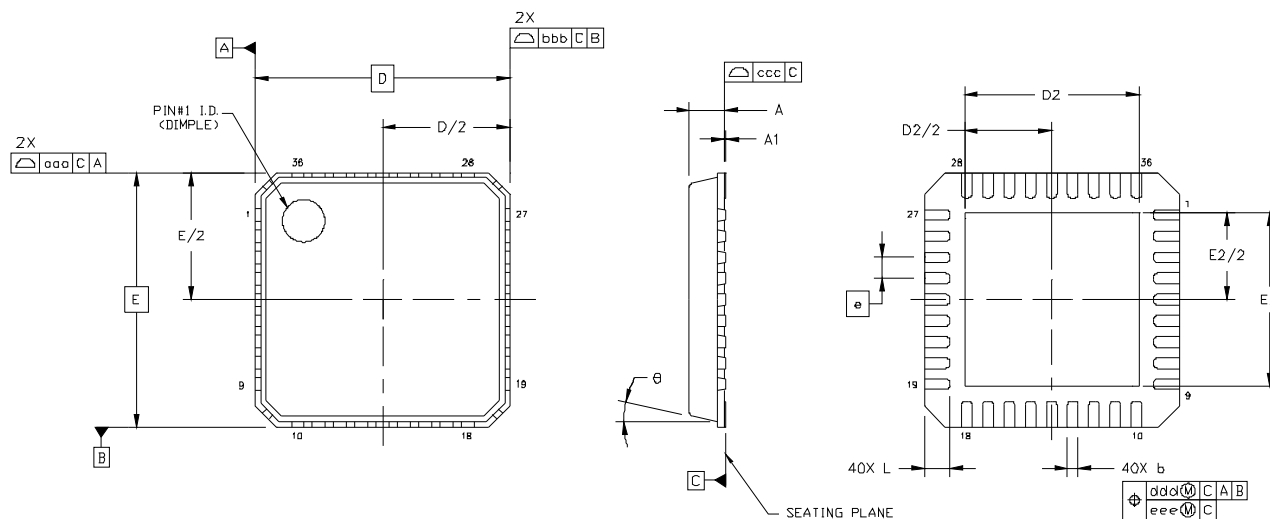

Figure 24. 36-Pin Quad Flat No-Lead (QFN)

Table 21. Package Dimensions

Symbol	Millimeters		
	Min	Nom	Max
A	0.80	0.85	0.90
A1	0.00	0.02	0.05
b	0.18	0.25	0.30
D	6.00 BSC		
D2	3.95	4.10	4.25
e	0.50 BSC		
E	6.00 BSC		
E2	3.95	4.10	4.25

Symbol	Millimeters		
	Min	Nom	Max
L	0.50	0.60	0.70
θ	—	—	12°
aaa	—	—	0.10
bbb	—	—	0.10
ccc	—	—	0.08
ddd	—	—	0.10
eee	—	—	0.05

Notes:

1. All dimensions shown are in millimeters (mm) unless otherwise noted.
2. Dimensioning and Tolerancing per ANSI Y14.5M-1994.
3. This drawing conforms to JEDEC outline MO-220, variation VJJD.
4. Recommended card reflow profile is per the JEDEC/IPC J-STD-020 specification for Small Body Components.

13. Recommended PCB Layout

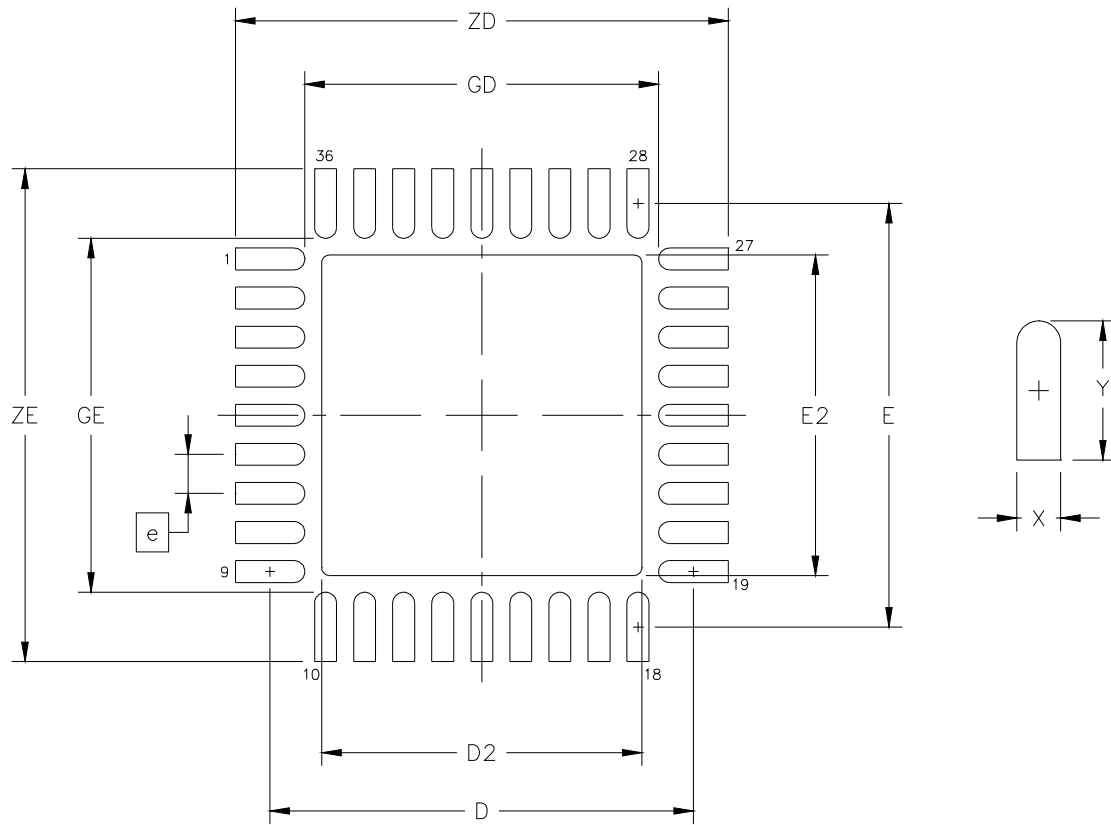

Figure 25. PCB Land Pattern Diagram

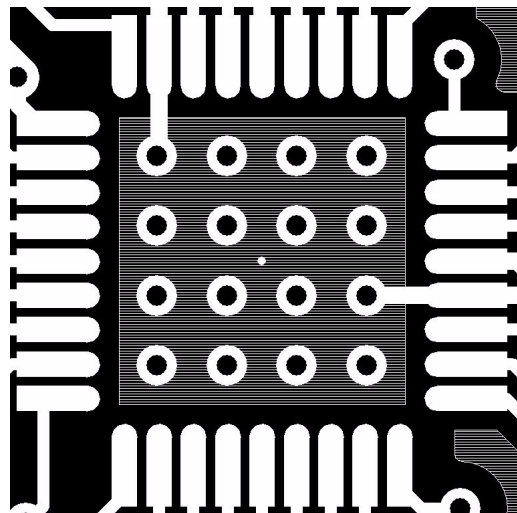

Figure 26. Ground Pad Recommended Layout

Table 22. PCB Land Pattern Dimensions

Dimension	MIN	MAX
e	0.50 BSC.	
E	5.42 REF.	
D	5.42 REF.	
E2	4.00	4.20
D2	4.00	4.20
GE	4.53	—
GD	4.53	—
X	—	0.28
Y	0.89 REF.	
ZE	—	6.31
ZD	—	6.31

Notes (General):

1. All dimensions shown are in millimeters (mm) unless otherwise noted.
2. Dimensioning and Tolerancing is per the ANSI Y14.5M-1994 specification.
3. This Land Pattern Design is based on IPC-SM-782 guidelines.
4. All dimensions shown are at Maximum Material Condition (MMC). Least Material Condition (LMC) is calculated based on a Fabrication Allowance of 0.05 mm.

Notes (Solder Mask Design):

1. All metal pads are to be non-solder mask defined (NSMD). Clearance between the solder mask and the metal pad is to be 60 μm minimum, all the way around the pad.

Notes (Stencil Design):

1. A stainless steel, laser-cut and electro-polished stencil with trapezoidal walls should be used to assure good solder paste release.
2. The stencil thickness should be 0.125 mm (5 mils).
3. The ratio of stencil aperture to land pad size should be 1:1 for the perimeter pads.
4. A 4 x 4 array of 0.80 mm square openings on 1.05 mm pitch should be used for the center ground pad.

Notes (Card Assembly):

1. A No-Clean, Type-3 solder paste is recommended.
2. The recommended card reflow profile is per the JEDEC/IPC J-STD-020 specification for Small Body Components.

Si5315

14. Si5315 Device Top Mark

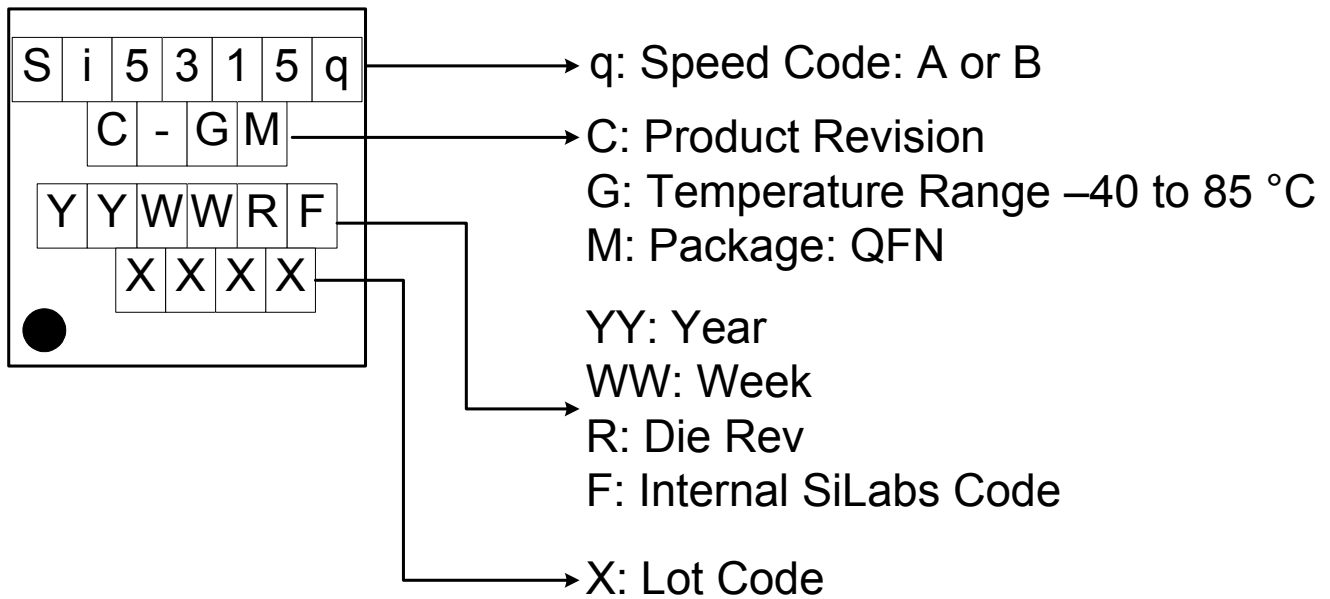

DOCUMENT CHANGE LIST:

Revision 0.1 to Revision 0.2

- Expanded/added numerous operating sections to initial data sheet

Revision 0.2 to Revision 0.25

- Updated features and application list
- Updated Section 1. "Electrical Specifications"
- Added voltage regulator block to Figure 6
- Revised footnotes in Table 7
- Removed plan #203 from Table 7
- Removed Figure 17. Crystal Oscillator with Feedback Resistor diagram from Section 6. "Crystal/Reference Clock Input"
- Added XA/XB jitter transfer plot to Section 6. "Crystal/Reference Clock Input"
- Added PSRR transfer function plot to Section 7. "Power Supply Filtering"
- Updated Typical phase noise plot and RMS jitter table in Section 8. "Typical Phase Noise Plots"

Revision 0.25 to Revision 0.26

- Corrected Section 11. "Ordering Guide" Output Clock Frequency Range for Si5315B-C-GM to 8 kHz–125 Mhz.

CONTACT INFORMATION

Silicon Laboratories Inc.

400 West Cesar Chavez
Austin, TX 78701
Tel: 1+(512) 416-8500
Fax: 1+(512) 416-9669
Toll Free: 1+(877) 444-3032

Please visit the Silicon Labs Technical Support web page:
<https://www.silabs.com/support/pages/contacttechnicalsupport.aspx>
and register to submit a technical support request.

The information in this document is believed to be accurate in all respects at the time of publication but is subject to change without notice. Silicon Laboratories assumes no responsibility for errors and omissions, and disclaims responsibility for any consequences resulting from the use of information included herein. Additionally, Silicon Laboratories assumes no responsibility for the functioning of undescribed features or parameters. Silicon Laboratories reserves the right to make changes without further notice. Silicon Laboratories makes no warranty, representation or guarantee regarding the suitability of its products for any particular purpose, nor does Silicon Laboratories assume any liability arising out of the application or use of any product or circuit, and specifically disclaims any and all liability, including without limitation consequential or incidental damages. Silicon Laboratories products are not designed, intended, or authorized for use in applications intended to support or sustain life, or for any other application in which the failure of the Silicon Laboratories product could create a situation where personal injury or death may occur. Should Buyer purchase or use Silicon Laboratories products for any such unintended or unauthorized application, Buyer shall indemnify and hold Silicon Laboratories harmless against all claims and damages.

Silicon Laboratories, Silicon Labs, and DSPLL are trademarks of Silicon Laboratories Inc.
Other products or brandnames mentioned herein are trademarks or registered trademarks of their respective holders.