

## Introducing Low Voltage DC Grid Interconnects

 **Tyco Electronics**  
Our commitment. Your advantage.

## KEY FEATURES

- **Power Feed Cable Assembly**
  - Releasable latching
  - Polarized housing
  - Plenum rated
- **Power Feed Connectors are available upon special request comprising of the following:**
  - Universal MATE-N-LOK housing (350777-1)
  - Universal MATE-N-LOK contacts (350923-3)
  - Strain relief (640713-2)
  - Self tapping screws (1-5025933-3)
- **Load (Device) Cable Assembly**
  - Releasable latching
  - Polarized housing
  - Plenum rated
- **Load (Device) Connectors are available upon special request comprising of the following:**
  - Housing (2106730-1)
  - Clamp (2106724-1)
  - Contacts (2106733-1)
  - Black heat shrink (2079524-1)
  - Yellow heat shrink (2079523-1)
- **Bus Bar to Bus Bar Cable Assembly**
  - Releasable latching
  - Polarized housing
  - Plenum rated
- **External Bus Bar (Fixture or Device) Connector**
  - Releasable latching
  - Polarized housing
  - Plenum rated
- **Internal Bus Bar (Fixture or Device) Connector**
  - Releasable latching
  - Positive latching
  - Threaded coupling
- **Plenum rated Universal MATE-N-LOK connector, part number 350786-1, available for panel/bulkhead side connector for power supply module**

## DESCRIPTIONS

**LVDC Grid Interconnects** are low voltage direct current (DC) connectors and cable assemblies developed to transfer power to and from lighting fixtures, power supplies, controls and other electrical devices intended for use in an EMerge Alliance® compliant system. The design allows for fixture and other electrical device adds, moves and changes on both sides of a bus bar structure, i.e. above and below a suspended ceiling, without the need for hard wire changes.

**LVDC Grid Interconnects** were designed specifically to meet the requirements of the EMerge Alliance® Standard, a new power distribution platform for the use of safe, low voltage DC Power in commercial interiors

## SYSTEM ADVANTAGES

A safe, low-voltage DC distribution system

Provides a plug and play standard for integrated management and control of more energy efficient and individually controllable devices such as LED lighting and other digital devices

Eliminates device level AC to DC electrical power conversions

Provides flexibility to readily arrange and rearrange lighting, actuators and other devices without the need for rewiring

Easier integration of on-site alternative energy sources such as solar, wind, fuel cell and batteries, with traditional AC power sources

## APPLICATIONS (Designed for use with the Emerge Alliance® compliant systems)

**Power Feed Cable Assembly** : Connects between a power server and a low voltage bus bar

**Load (Device) Cable Assembly** : Connects lighting fixtures and other electrical devices to low voltage bus bar

**Bus Bar to Bus Bar Cable Assembly** : Connects sections of low voltage bus bar together

**External Bus Bar (Fixture or Device) Connector** : Mounts directly to a drop-in fixture enabling connection to a bus bar component, especially when the bus bar is incorporated in a suspended ceiling grid

**Internal Bus Bar (Fixture or Device) Connector** : Provides mounting and electrical interconnect for lighting fixtures and other devices mounted to a suspended ceiling grid, i.e. and Armstrong DC FlexZone™ Suspended System

## MECHANICAL

**Environmental operating temperature** : -55° to 85° C

**Internal Bus Bar (Fixture or Device) Connector** : 50 cycles

**External Bus Bar (Fixture or Device) Connector** : 50 cycles

**Load (Device) Cable Assembly** : 50 cycles

**Power Feed Cable Assembly** : 10 cycles

**Bus Bar to Bus Bar Cable Assembly** : 10 cycles



## ELECTRICAL

**Operating current** : Up to 4.1 Amps

**Operating voltage** : 24 Volts DC (nominal)

## MATERIALS

**Housings** : Thermoplastic

**Contacts** : Phosphor bronze

**Finish** : Tin over nickel

## STANDARDS AND SPECIFICATIONS

EMerge Alliance® System Standard (Pending)

UL2577

ANSI/NFPA 70

**Application Specification** : 114-13275

**Product Specification** : 108-2414

## Typical EMerge Alliance® Compliant System

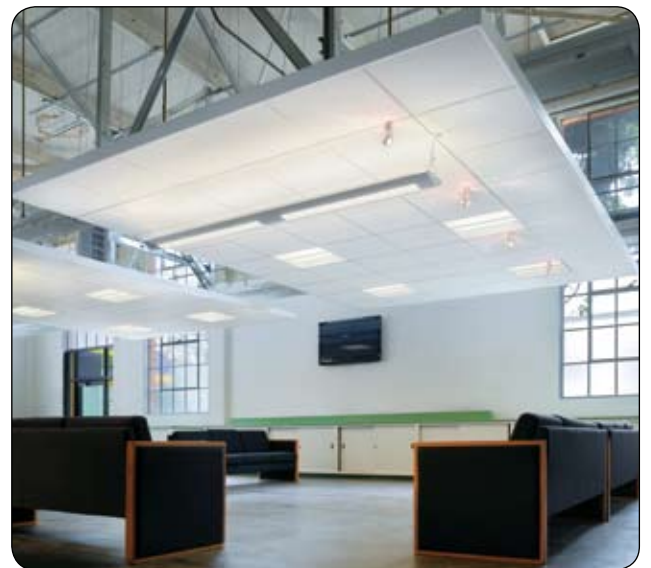
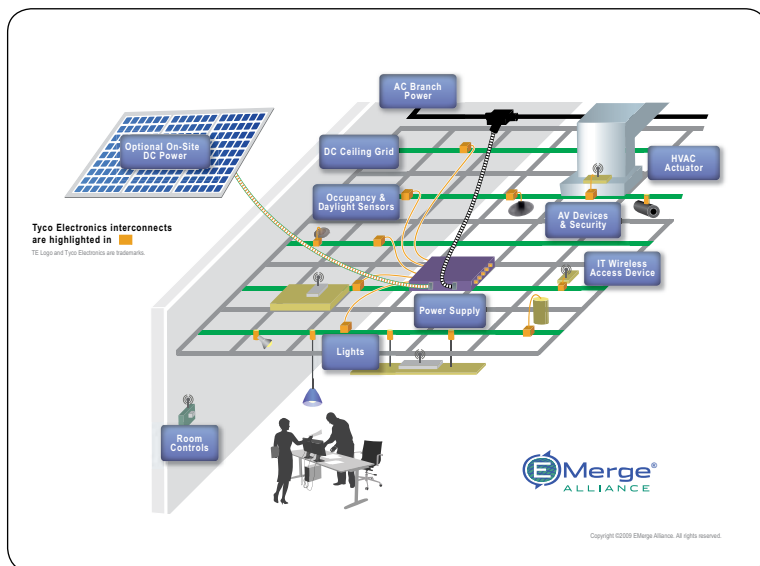

\*Diagram courtesy of EMerge Alliance® Corporation

\*Suspended ceiling grid shown in photos is Armstrong DC FlexZone™ Silhouette, courtesy of Armstrong Ceilings.  
\*EMerge Alliance® is a registered trademark of the EMerge Alliance® Corporation.

PRODUCT DIMENSIONS

Power Feed Cable Assembly

Part Number	Length ft [mm]
2106725-1	5.0 [1524.0]
2106725-2	10.0 [3048.0]
2106725-3	15.0 [4572.0]
2106725-4	20.0 [6098.0]

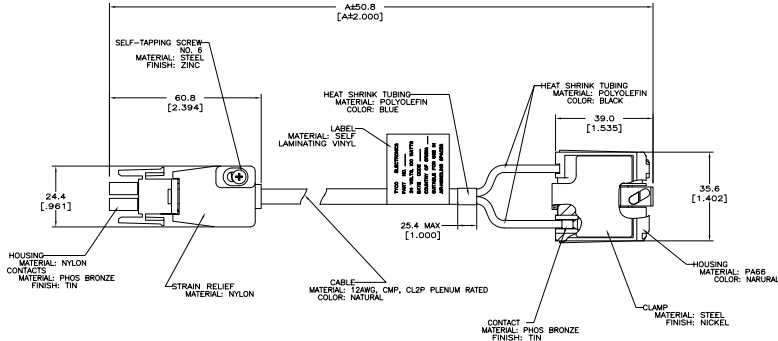

Bus Bar to Bus Bar Cable Assembly

Part Number	Length ft [mm]
2106728-1	3.0 [914.4]

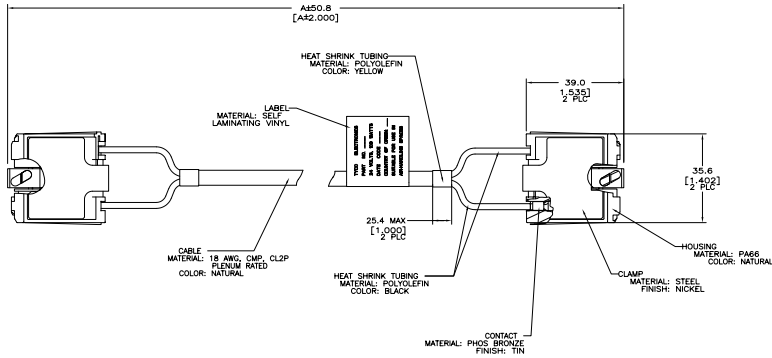

Load (Device) Cable Assembly

Part Number	Length ft [mm]
2106718-1	5.0 [1524.0]
2106718-2	10.0 [3048.0]

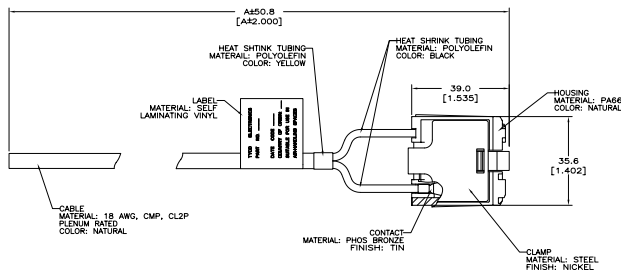

## PRODUCT DIMENSIONS Cont.

### External Bus Bar (Fixture or Device) Connector

Part Number	Wire Size
2106739-1	18 AWG Solid

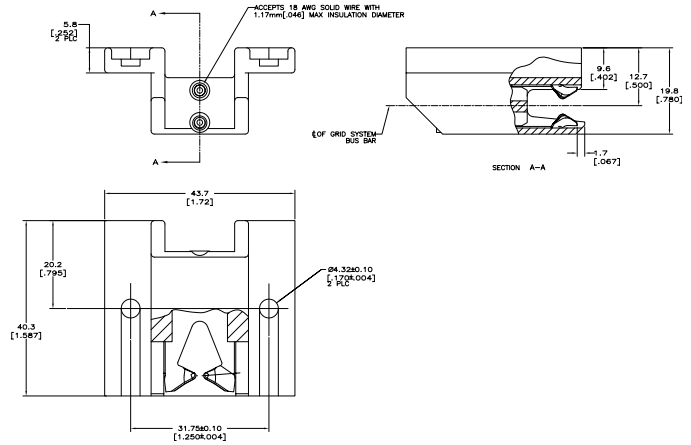
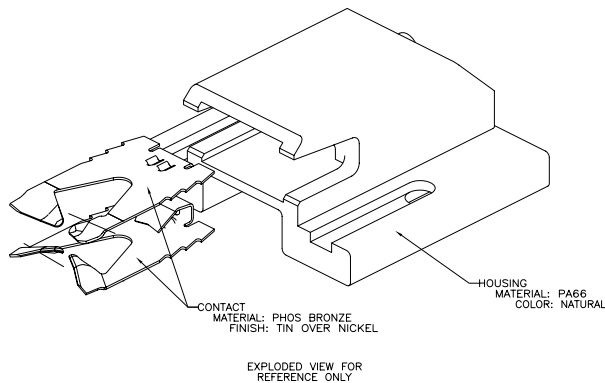

### Internal Bus Bar (Fixture or Device) Connector

Part Number	Wire Size
2106710-1	18 AWG

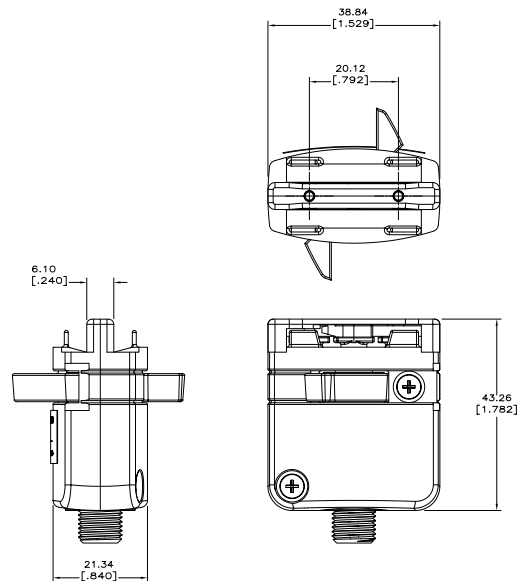
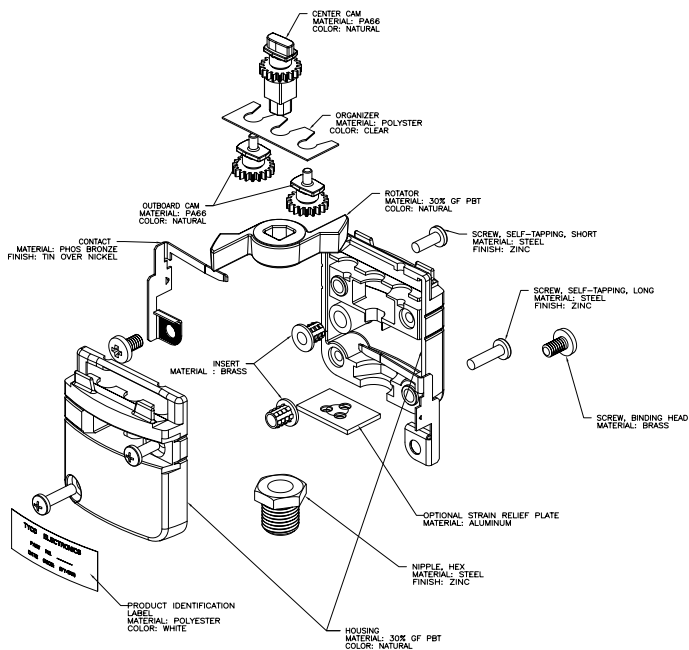

## FOR MORE INFORMATION

[www.tycoelectronics.com/lighting](http://www.tycoelectronics.com/lighting)

### Technical Support

Internet:	<a href="http://www.tycoelectronics.com/help">www.tycoelectronics.com/help</a>
USA:	+1 (800) 522-6752
Canada:	+1 (905) 470-4425
Mexico & Central America:	+52(0) 55-1106-0814
South America:	+55 (0) 11-2103-6000
Germany:	+49 (0) 6251-133-1999
UK:	+44 (0) 800-267266
France:	+33 (0) 1-3420-8686
Netherlands:	+31 (0) 73-6246-999
China:	+86 (0) 400-820-6015

Part numbers in this brochure are RoHS Compliant\*, unless marked otherwise.

\*as defined [www.tycoelectronics.com/leadfree](http://www.tycoelectronics.com/leadfree)

### Tyco Electronics Corporation

Harrisburg, PA

[tycoelectronics.com](http://tycoelectronics.com)

© 2010 Tyco Electronics Corporation All Rights Reserved.

7-1773456-1 4M FP 02/2010

MATE-N-LOK, TE (logo) and Tyco Electronics are trademarks of the Tyco Electronics group of companies and its licensors.

Other products, logos, and Company names mentioned herein may be trademarks of their respective owners.

While Tyco Electronics has made every reasonable effort to ensure the accuracy of the information in this catalog, Tyco Electronics does not guarantee that it is error-free, nor does Tyco Electronics make any other representation, warranty or guarantee that the information is accurate, correct, reliable or current. Tyco Electronics reserves the right to make any adjustments to the information contained herein at any time without notice. Tyco Electronics expressly disclaims all implied warranties regarding the information contained herein, including, but not limited to, any implied warranties of merchantability or fitness for a particular purpose. The dimensions in this catalog are for reference purposes only and are subject to change without notice. Specifications are subject to change without notice. Consult Tyco Electronics for the latest dimensions and design specifications.

