



Specifications

| | | |
|----------------------|---|--|
| Nominal Size | 50 mm (2.00 in) | (See attached drawing) |
| Impedance | 8 Ohm \pm 15% | at 800 Hz 1 V |
| Resonant frequency | 430 Hz \pm 86 Hz | at 1 V |
| Sound pressure level | 89 dB/w \pm 3 dB | 0.25 w 50 cm ave. at 0.8K, 1.0K, 1.2K, 1.5K Hz |
| Response | Fo Hz ~4 KHz max 10 dB | |
| Input power | Nominal 0.25 W | Handling capacity 0.5 W |
| Operation | must be normal at program source 0.25 W | |
| Buzz, rattle, etc. | must be normal at sine wave 1.41 V | |
| Magnet | Size: 13 x 10 mm | |
| Load test | White noise 0.25 W for | 5 hours |
| Heat test | 40 \pm 2° C | 20-50% R.H. 5 hours |
| Humidity test | 40 \pm 2° C | 90-95% R.H. 5 hours |

Frequency Response Curve

| | |
|-----------------------|------------|
| Potentiometer range | 50 dB |
| Rectifier | RMS |
| Lower limit frequency | 20 Hz |
| Wr. speed | 100 mm/sec |

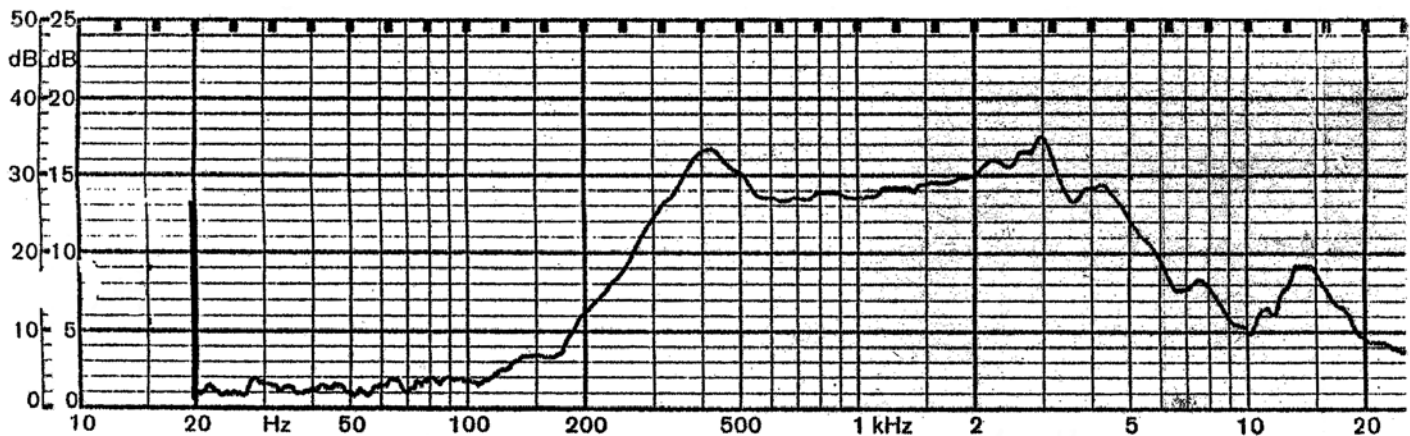

Zero level 60 dB

| REV. | DESCRIPTION | DATE |
|------|-------------|-----------|
| A | NEW DRAWING | 9/15/2006 |

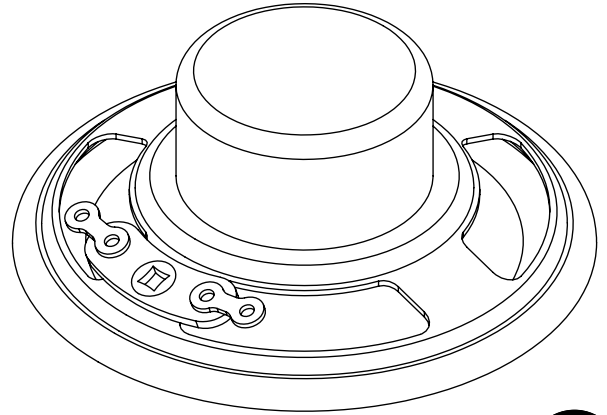
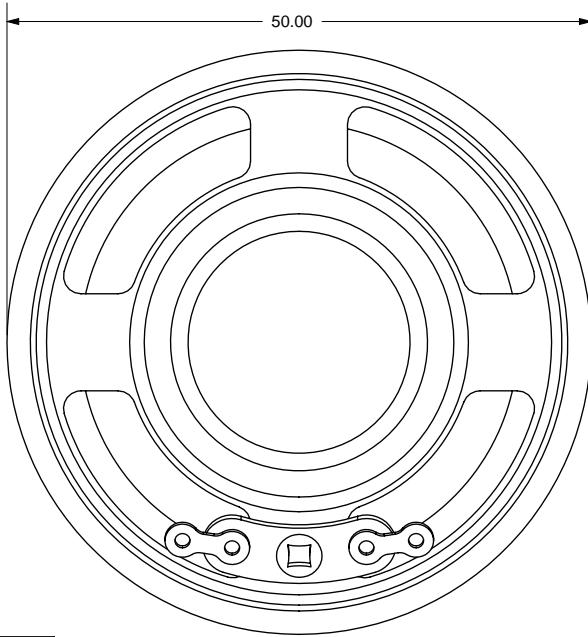
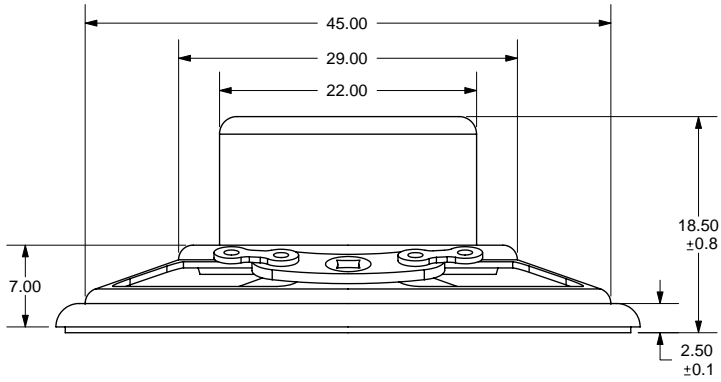

TOLERANCE:
±0.5mm UNLESS OTHERWISE
SPECIFIED



20050 SW 112th Ave.
Tualatin, OR 97062
Phone: 503-643-4899
800-275-4899
Fax: 503-372-1266
Website: www.cui.com

| | | |
|---|--------------------|------------|
| TITLE: Round frame paper cone - alnico magnet | | REV: A |
| PART NO. GA0501 | UNITS: MM [INCHES] | |
| DRAWN BY: ZRJ | APPROVED BY: | SCALE: 2:1 |

PC FILE NAME:
GA0501

COPYRIGHT 2006 BY CUI INC.