



Specifications

Nominal Size	30 mm		
Impedance	8 Ohm \pm 15%	at	1.5 KHz 1 V
Resonant frequency	500 Hz \pm 100 Hz	at	1 V
Sound pressure level	78 dB/w \pm 3 dB	0.2 w 50 cm ave. at 0.8K, 1K, 1.2K, 1.5K Hz	
Response	Fo Hz ~ 6 KHz max 10 dB		
Input power	Nominal 0.2 W	Handling capacity	0.3 W
Operation	must be normal at program source 0.2 W		
Buzz, rattle, etc.	must be normal at sine wave 1.26 V		
Magnet	Size: 9.5 x 1.0 mm		
Load test	White noise	0.2 W for	24 hours
Heat test	60 \pm 2° C	20-50% R.H.	24 hours
Humidity test	40 \pm 2° C	90-95% R.H.	24 hours

Frequency Response Curve

Potentiometer range	50 dB
Rectifier	RMS
Lower limit frequency	20 Hz
Wr. speed	100 mm/sec

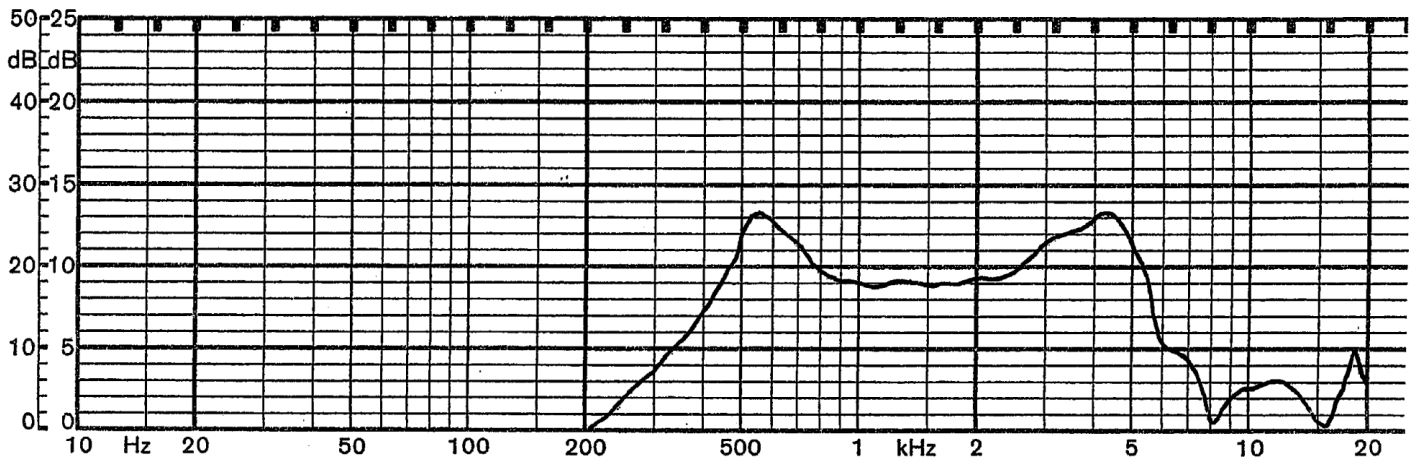

Zero level 60 dB

REV.	DESCRIPTION	DATE
A	NEW DRAWING	7/3/2007

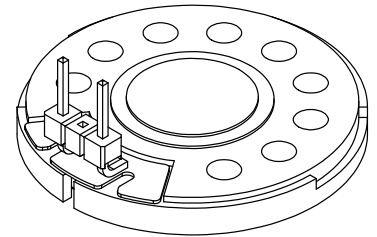
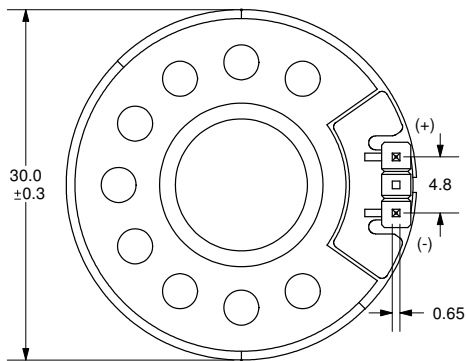
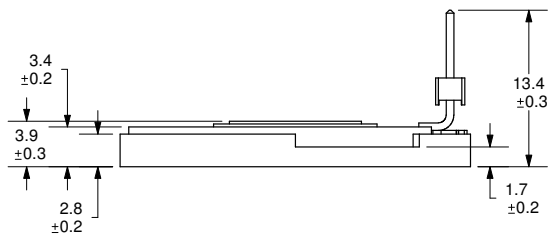

TOLERANCE:
±0.5mm UNLESS OTHERWISE
SPECIFIED



20050 SW 112th Ave.
Tualatin, OR 97062
Phone: 503-612-2300
800-275-4899
Fax: 503-612-2383
Website: www.cui.com

TITLE: LOW PROFILE SPEAKER		REV: A
PART NO. CLS0301MP-1	UNITS: MM [INCHES]	
DRAWN BY: ZRJ	APPROVED BY:	SCALE: 2:1

PC FILE NAME:
CLS0301MP-1

COPYRIGHT 2007 BY CUI INC.