

PART NUMBER: CMT-1102

DESCRIPTION: piezo audio transducer

SPECIFICATONS

operating voltage	25.0 Vp-p max.	
current consumption	4.5 mA max.	at 5 Vp-p, square wave, 4.1 KHz
sound pressure level	73 db min.	at 10 cm / 5 Vp-p, square wave, 4.1 KHz
electrostatic capacitance	12,000 pF ±30%	at 1KHz / 1 V
operating temperature	-40 ~ +80° C	
storage temperature	-40 ~ +80° C	
dimensions	ø11.0 x W9.0 x H1.7 mm	
weight	0.5 g max.	
material	LCP (white)	
terminal	SMD type	
RoHS	yes	

APPEARANCE DRAWING

tolerance: ±0.3

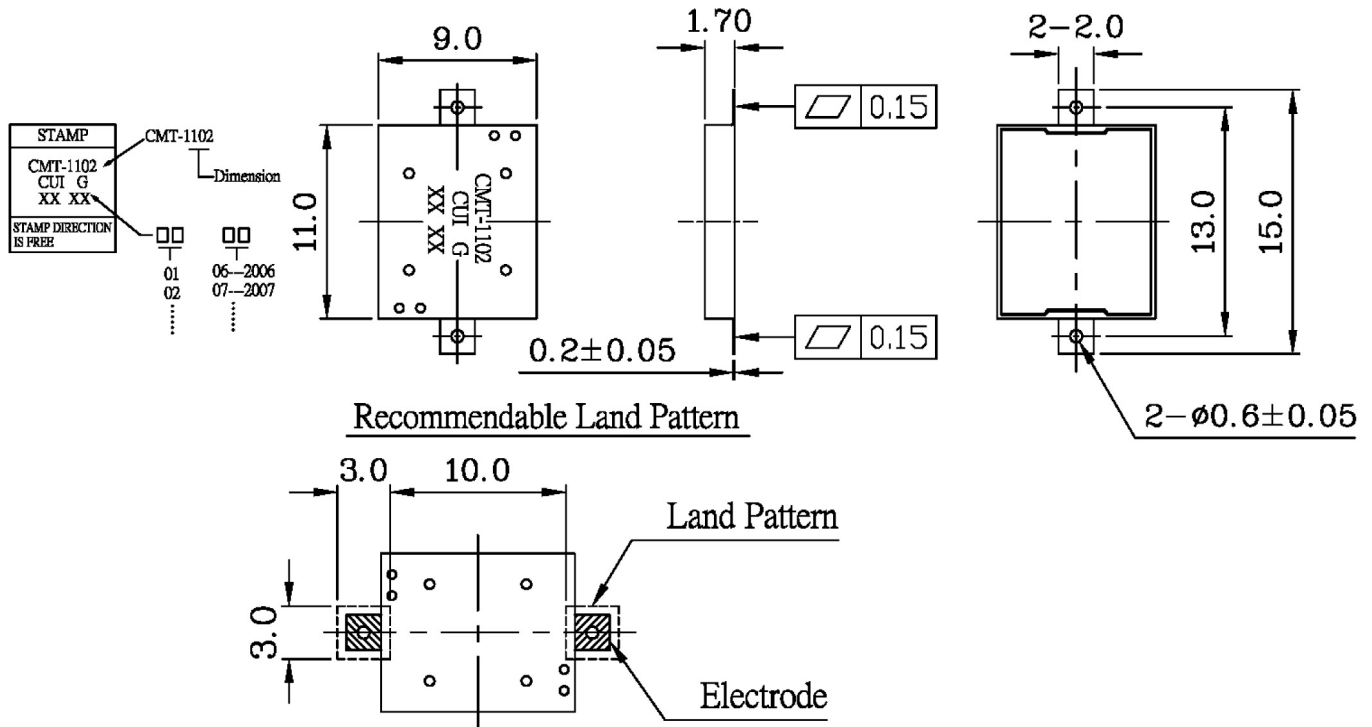

PART NUMBER: CMT-1102

DESCRIPTION: piezo audio transducer

TYPICAL FREQUENCY RESPONSE CURVE

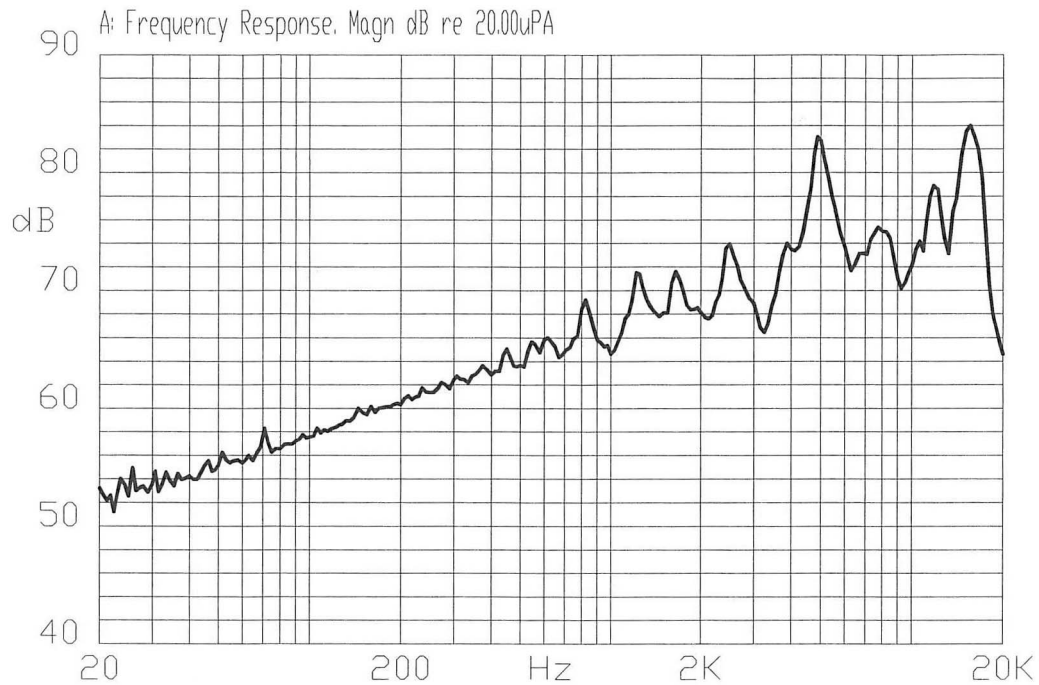

MEASUREMENT METHOD

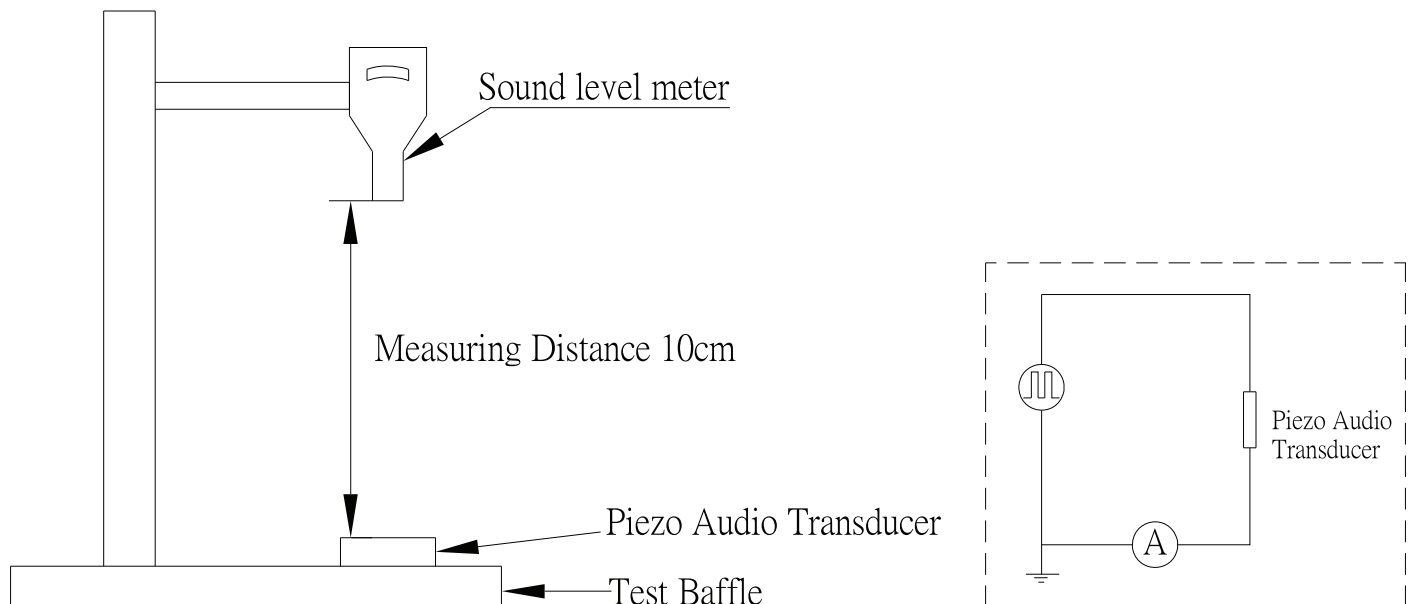

S.P.L. Measuring Circuit
 Input Signal: 5Vp-p, 4.1 KHz, square wave
 Mic: RION S.P.L. meter UC30 or equivalent
 S.G.: Hewlett Packard 33120A function generator or equivalent

PART NUMBER: CMT-1102

DESCRIPTION: piezo audio transducer

MECHANICAL CHARACTERISTICS

item	test condition	evaluation standard
solderability	Lead terminals are immersed in rosin for 5 seconds and then immersed in solder bath of 230 ±5°C for 2 ±0.5 seconds.	95% of the lead pad surface must be covered with solder
soldering heat resistance	1) IR Reflow Pre-heating conditions will be 140~160°C for 60~120 seconds. Ascending time up to 150°C should be longer than 30 seconds. Heating conditions should be within 10 seconds at 230°C min. Peak temperature should be lower than 255°C and then be placed in natural conditions for 1 hour before being measured. 2) Soldering Iron Soldering iron of 270±5°C should be placed 0.5mm above the transducer electrode. Melting solder should be applied to electrode for 3±1 seconds and then be placed in natural conditions for 4 hours before being measured.	No interference in operation.
terminal mechanical strength	For 10 seconds, the force of 9.8N (1.0kg) is applied to each terminal in axial direction.	No damage or cutting off.
vibration	The buzzer should be subjected to a vibration cycle of 10 to 55 Hz for a period of 1 minute. Peak amplitude should be 1.55mm. The vibration test should consist of 2 hours to each of the 3 perpendicular directions.	After the test, the part should meet specifications without any damage in appearance and performance, except SPL. SPL should be within ±10dB compared with the initial measurement.

ENVIRONMENT TEST

item	test condition	evaluation standard
high temp. test	After being placed in a chamber at +80°C for 240 hours.	The buzzer will be measured after being placed at +25°C for 4 hours. The value of the oscillation frequency/current consumption should be ±10% compared to the initial measurements. The SPL should be within ±10dB compared to the initial measurements.
low temp. test	After being placed in a chamber at -40°C for 240 hours.	
humidity test	After being placed in a chamber at +40°C and 90±5% relative humidity for 240 hours.	
temp. cycle test	The part shall be subjected to 5 cycles. One cycle will consist of:	

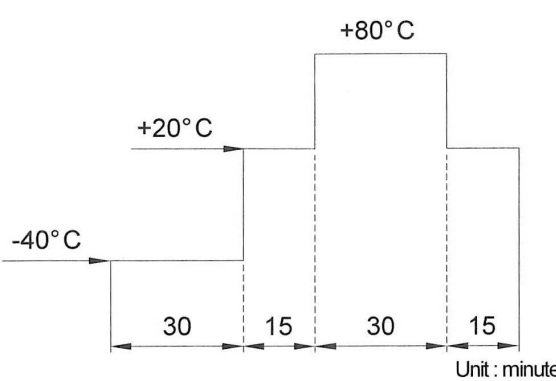

Unit : minute

PART NUMBER: CMT-1102

DESCRIPTION: piezo audio transducer

RELIABILITY TEST

item	test condition	evaluation standard
operating (life test)	<p>1. Continuous life test: The part will be subjected to 48 hours of continuous operation at +65°C with rated voltage applied.</p> <p>2. Intermittent life test: A duty cycle of 1 minute on, 1 minute off, a minimum of 5,000 times at room temp (+25 ±2°C) with rated voltage applied.</p>	<p>The buzzer will be measured after being placed at +25°C for 4 hours. The value of the oscillation frequency/current consumption should be ±10% compared to the initial measurements. The SPL should be within ±10dB compared to the initial measurements.</p>

TEST CONDITIONS

standard test condition	a) temperature: +5 ~ +35°C	b) humidity: 45 - 85%	c) pressure: 860-1060 mbar
judgement test condition	a) temperature: +25 ±2°C	b) humidity: 60 - 70%	c) pressure: 860-1060 mbar

RECOMMENDED TEMPERATURE PROFILE FOR REFLOW OVEN

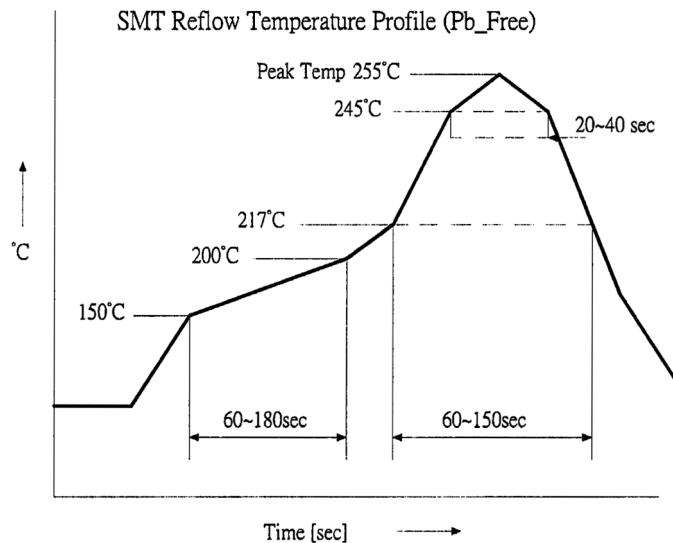

PART NUMBER: CMT-1102

DESCRIPTION: piezo audio transducer

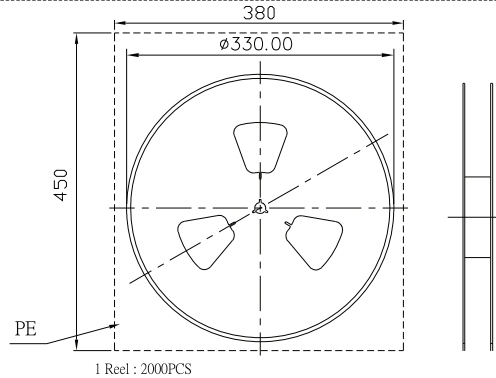
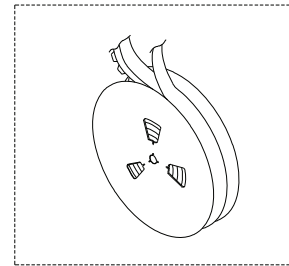
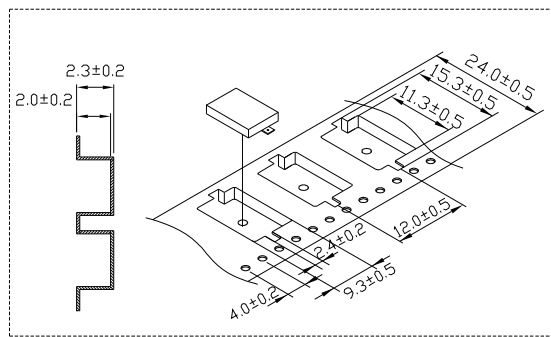
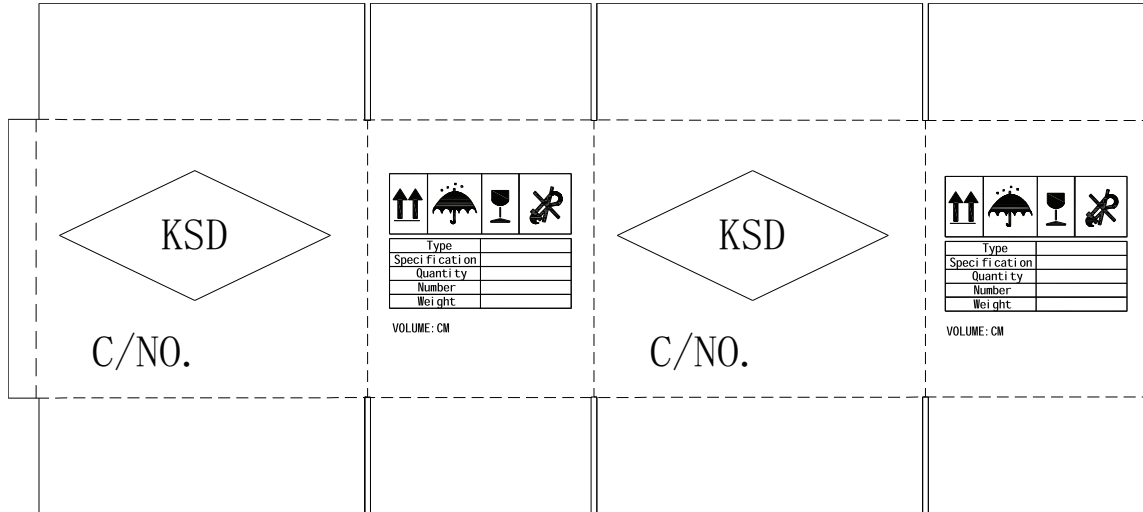
PACKAGING

1. CUI Inv#. 037-4398R
CUI part#. CMT-1102
2. RoHS Compliant

Inner Box	340mmx340mmx40mm	1x2000PCS=2000PCS
Carton Box	350mmx175mmx355mm	5x2000PCS=10000PCS

