

PRODUCT NUMBER
SEE NOTE 3
10007290-XXXXXCXLF

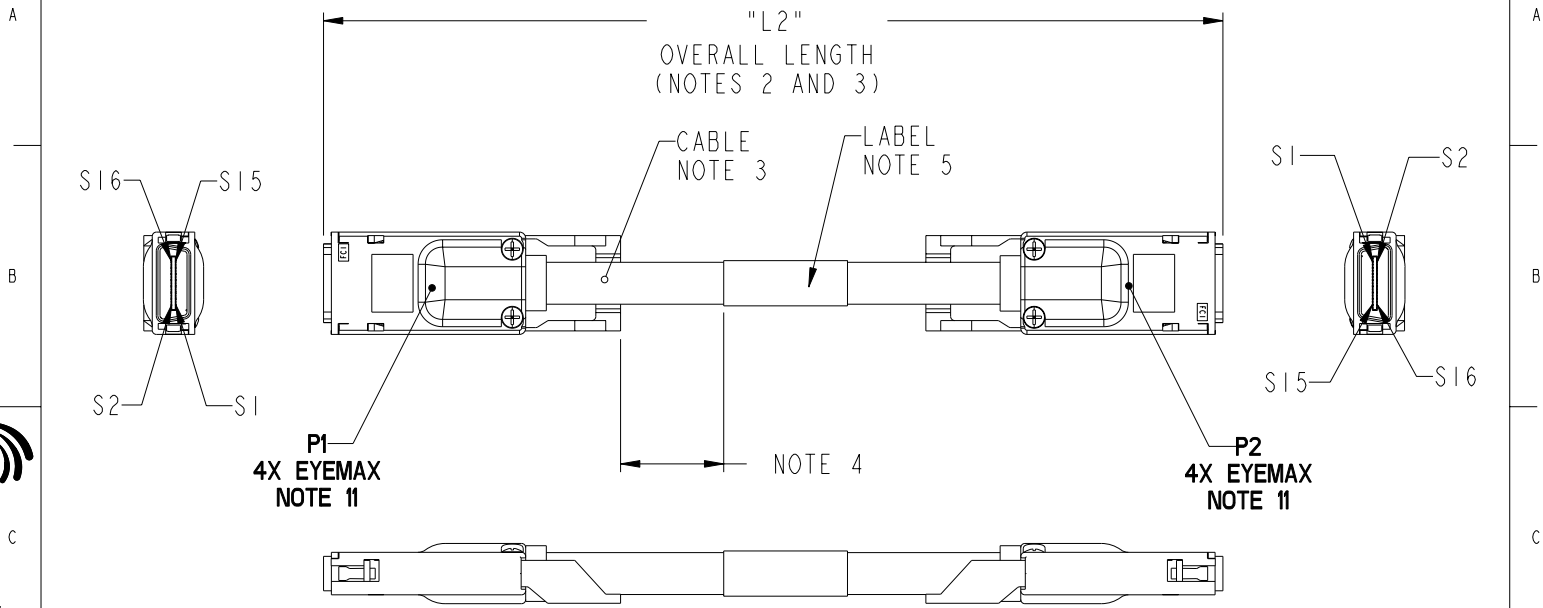

FCJ
Copyright FCJ.

www.fciconnect.com		surface	tolerance std	projection	MM
		TOLERANCES UNLESS OTHERWISE SPECIFIED			
Dr	D. INGRAM	2007-01-04	ANGULAR	size	A4
Eng	C. GROSS	2007-01-04	LINEAR	0.xx	±0.10
Chr	C. GROSS	2007-01-04	0° ±°	ECN	V06-1193
Appr	C. GROSS	2007-01-04	Product family	C&A	Spec ref
FCJ		4X EYEMAX LATCH-STYLE		part no	10007290
		CABLE ASSEMBLY (INFINIBAND™)		Rev.	H
catalog no		-		CUSTOMER	sheet 1 of 3

rev	ecn no	dr	date
H	V06-1193	DAI	2007-01-04

PRODUCT NUMBER
SEE NOTE 3
10007290-XXXXCXLF

PIN OUT/WIRING LIST
SEE NOTE 6

A

B

C

D

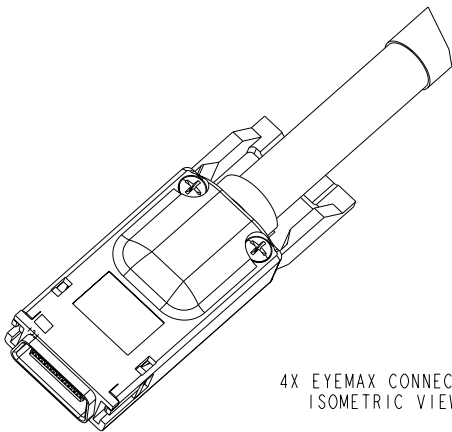

4X EYEMAX CONNECTOR
ISOMETRIC VIEW

P1		P2	
PIN NUMBER	WIRE ID	PIN NUMBER	WIRE ID
GI-G9	GROUND	GI-G9	GROUND
S1	IBtxlp(0)	S16	IBtxOp(0)
S2	IBtxln(0)	S15	IBtxOn(0)
S3	IBtxlp(1)	S14	IBtxOp(1)
S4	IBtxln(1)	S13	IBtxOn(1)
S5	IBtxlp(2)	S12	IBtxOp(2)
S6	IBtxln(2)	S11	IBtxOn(2)
S7	IBtxlp(3)	S10	IBtxOp(3)
S8	IBtxln(3)	S9	IBtxOn(3)
S9	IBtxOp(3)	S8	IBtxln(3)
S10	IBtxOp(2)	S7	IBtxlp(3)
S11	IBtxOn(2)	S6	IBtxln(2)
S12	IBtxOp(2)	S5	IBtxlp(2)
S13	IBtxOn(1)	S4	IBtxln(1)
S14	IBtxOp(1)	S3	IBtxlp(1)
S15	IBtxOn(0)	S2	IBtxln(0)
S16	IBtxOp(0)	S1	IBtxlp(0)

A

B

C

D

	title	4X EYEMAX LATCH-STYLE CABLE ASSEMBLY (INFINIBAND™)	drwg no	10007290	Rev.	H
	catalog no	-	CUSTOMER	sheet 2 of 3		

REV F - 2008-04-17

PRODUCT NUMBER
SEE NOTE 3
10007290-XXXXXCXLF

NOTES:

1. MATING RECEPTACLE DRAWINGS FCI 58368 OR 58369.
 2. UNLESS OTHERWISE SPECIFIED ASSEMBLED LENGTH TOLERANCE =
 < 1 METER = +/- 15.0mm
 > 1 METER TO 10 METER = +/- 2% OF L2
 > 10 METER = +0.00%/ -4% OF L2

3. PART NUMBER DESCRIPTION: PENDING
 10007290-X XX XX C X LF

SIGNAL WIRE
 GAGE (AWG)
 M: 24 AWG
 N: 26 AWG
 P: 28 AWG
 R: 30 AWG

LEAD FREE (SEE NOTE 10)
 E: EQUALIZED
 U: UN-EQUALIZED
 HARDWARE TYPE
 C: PULL TAB

OVERALL LENGTH OF CABLE
 XXXX = XX METERS, XX CENTIMETERS
 EXAMPLES OF XXXX:
 0046 = 0 METERS 46 CENTIMETERS
 0850 = 8 METERS 50 CENTIMETERS

10. LEAD FREE PRODUCTS MEET EUROPEAN UNION DIRECTIVES AND OTHER COUNTRY REGULATIONS AS DESCRIBED IN GS-22-008.

LEAD FREE SOLDER TAIL PLATING 2um (80u") MIN. MATTE TIN OVER 1.27um (50u") MIN. NICKEL UNDERPLATE.

PACKAGING OF LEAD FREE PRODUCTS MEETS LABELING AND PACKAGING SPECIFICATION GS-14-920.

11. CONNECTOR ASSEMBLIES SHOWN ARE FOR REFERENCE ONLY AND MAY NOT SHOW ALL PART DETAIL. REFERENCE CONNECTOR ASSEMBLY DRAWINGS FOR COMPLETE DETAILS.

12. GLOBAL STANDARDS FOR CABLE PACKAGING: GS-14-1093.

13. MATERIALS:
 CABLE: FULLY SHIELDED, 8 DIFFERENTIAL PAIRS
 COVERS: ZINC ALLOY WITH NICKEL OVERPLATE
 CABLE COLLARS AND PULL TABS: PLASTIC
 PLUG ASSEMBLIES: THERMOPLASTIC AND COPPER ALLOY
 LATCH: STAINLESS STEEL
 PCB BOARD: FR4 FIBERGLASS

EXAMPLE: 10007290- M0850CULF = 24 AWG, 8.50 METER, PULL TAB, UNEQUALIZED, LEAD FREE

4. UNLESS OTHERWISE SPECIFIED LABEL POSITION SHALL BE APPROXIMATELY 50mm FROM REAR OF CONNECTOR.

5. LABEL DETAILS:
 -MANUFACTURER CODE OR NAME
 -CUSTOMER P/N OR FCI P/N
 -REVISION
 -DATE CODE WW/YY FORMAT
 -COUNTRY ORIGIN

FONT SHALL BE CLEARLY VISIBLE AND BLACK IN COLOR.

6. ALL CABLE ASSEMBLIES SHALL BE TESTED 100% FOR CONTINUITY AS DEFINED IN WIRING LIST.
 7. UNLESS OTHERWISE SPECIFIED ALL CABLE ASSEMBLIES SHALL BE 100% HI-POT TESTED BY APPLYING 300V FOR MINIMUM OF 10ms, UNLESS ACTIVE COMPONENTS ARE USED IN THIS ASSEMBLY.
 8. OTHER TESTING PERFORMED AS REQUIRED BY PRODUCT SPECIFICATION:GS-12-216. S-12-216 AND CONNECTOR PRODUCT SPECIFICATION GS-12-209.
 9. CABLE ASSEMBLIES SHALL WITHSTAND AN AXIAL LOAD OF 171bs/75N AT A RATE OF 25.4mm PER MINUTE, DURATION OF 1 (ONE) HOUR, WITHOUT DAMAGE TO CABLE OR CONNECTOR. CABLE PRODUCT SPECIFICATION: GS-12-216 CONNECTOR PRODUCT SPECIFICATION: GS-12-209

	4X EYEMAX LATCH-STYLE	10007290	Rev. H
	CABLE ASSEMBLY (INFINIBAND™)	CUSTOMER	sheet 3 of 3
catalog no	-		

REV F - 2008-04-17