

Reflowable Manganese Lithium Coin Batteries (ML-RH series): Individual Specifications

ML414RH

■ Dimensions(mm)

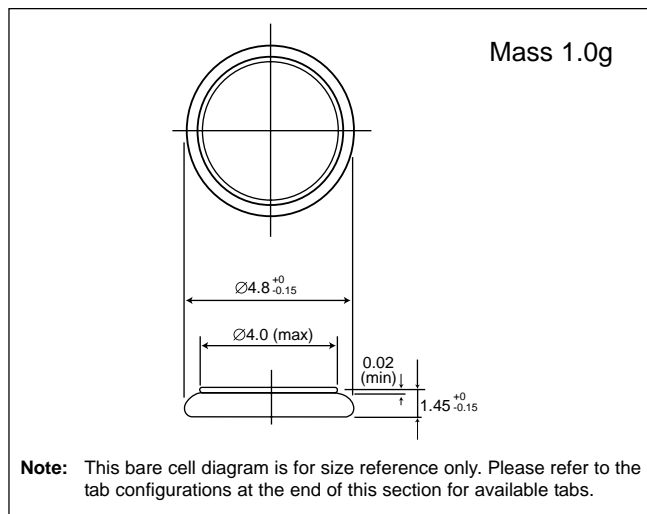

■ Specification

Nominal voltage (V)	3
Nominal capacity (mAh)	1.0*1
Continuous standard load (mA)	0.005
Operating temperature (C)	-20 ~ +60

*1Nominal capacity shown above is based on standard drain and cut off voltage down to 2.0V at 20°C.

■ Discharge characteristics

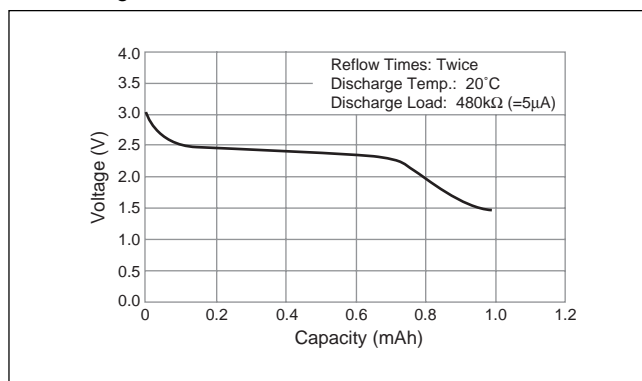

■ Charge Voltage vs. Discharge Capacity

