



2.5V SINGLE DATA RATE 1:10 CLOCK BUFFER TERABUFFER™ JR.

IDT5T9070

FEATURES:

- Optimized for 2.5V LVTTTL
- Guaranteed Low Skew < 25ps (max)
- Very low duty cycle distortion < 300ps (max)
- High speed propagation delay < 2ns. (max)
- Up to 200MHz operation
- Very low CMOS power levels
- Hot insertable and over-voltage tolerant inputs
- 1:10 fanout buffer
- 2.5V V_{DD}
- Available in TSSOP package

APPLICATIONS:

- Clock and signal distribution

DESCRIPTION:

The IDT5T9070 2.5V single data rate (SDR) clock buffer is a single-ended input to ten single-ended outputs buffer built on advanced metal CMOS technology. The SDR clock buffer fanout from a single input to ten single-ended outputs reduces the loading on the preceding driver and provides an efficient clock distribution network.

The IDT5T9070 has two output banks that can be asynchronously enabled/disabled. Multiple power and grounds reduce noise.

FUNCTIONAL BLOCK DIAGRAM

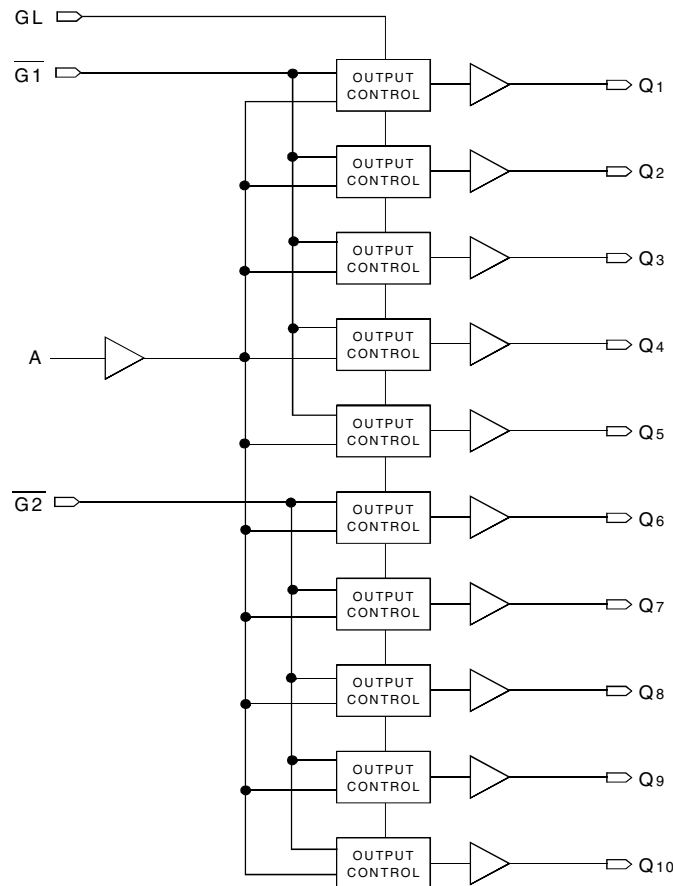

The IDT logo is a registered trademark of Integrated Device Technology, Inc.

INDUSTRIAL TEMPERATURE RANGE

OCTOBER 2002

PIN CONFIGURATION

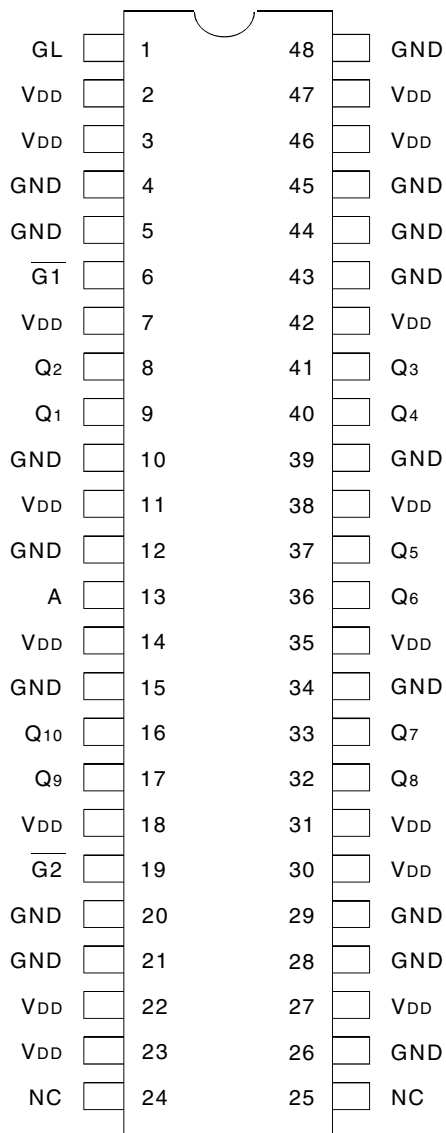

TSSOP
TOP VIEW

ABSOLUTE MAXIMUM RATINGS⁽¹⁾

Symbol	Description	Max	Unit
V _{DD}	Power Supply Voltage	-0.5 to +3.6	V
V _I	Input Voltage	-0.5 to +3.6	V
V _O	Output Voltage	-0.5 to V _{DD} +0.5	V
T _{STG}	Storage Temperature	-65 to +165	°C
T _J	Junction Temperature	150	°C

NOTE:

- Stresses greater than those listed under ABSOLUTE MAXIMUM RATINGS may cause permanent damage to the device. This is a stress rating only and functional operation of the device at these or any other conditions above those indicated in the operational sections of this specification is not implied. Exposure to absolute maximum rating conditions for extended periods may affect reliability.

CAPACITANCE⁽¹⁾ (T_A = +25°C, F = 1.0MHz)

Symbol	Parameter	Min	Typ.	Max.	Unit
C _{IN}	Input Capacitance	—	6	—	pF

NOTE:

- This parameter is measured at characterization but not tested.

RECOMMENDED OPERATING RANGE

Symbol	Description	Min.	Typ.	Max.	Unit
T _A	Ambient Operating Temperature	-40	+25	+85	°C
V _{DD}	Internal Power Supply Voltage	2.3	2.5	2.7	V

PIN DESCRIPTION

Symbol	I/O	Type	Description
A	I	LVTTTL	Clock input
$\overline{G1}$	I	LVTTTL	Gate for outputs Q1 through Q5. When $\overline{G1}$ is LOW, these outputs are enabled. When $\overline{G1}$ is HIGH, these outputs are asynchronously disabled to the level designated by GL ⁽¹⁾ .
$\overline{G2}$	I	LVTTTL	Gate for outputs Q6 through Q10. When $\overline{G2}$ is LOW, these outputs are enabled. When $\overline{G2}$ is HIGH, these outputs are asynchronously disabled to the level designated by GL ⁽¹⁾ .
GL	I	LVTTTL	Specifies output disable level. If HIGH, the outputs disable HIGH. If LOW, the outputs disable LOW.
Qn	O	LVTTTL	Clock outputs
V _{DD}		PWR	Power supply for the device core, inputs, and outputs
GND		PWR	Power supply return for power

- NOTE:**
- Because the gate controls are asynchronous, runt pulses are possible. It is the user's responsibility to either time the gate control signals to minimize the possibility of runt pulses or be able to tolerate them in down stream circuitry.

DC ELECTRICAL CHARACTERISTICS OVER OPERATING RANGE ⁽¹⁾

Symbol	Parameter	Test Conditions	Min.	Typ. ⁽⁴⁾	Max	Unit
I _{IH}	Input HIGH Current	V _{DD} = 2.7V V _I = V _{DD} /GND	—	—	±5	μA
I _{IL}	Input LOW Current	V _{DD} = 2.7V V _I = GND/V _{DD}	—	—	±5	
V _{IK}	Clamp Diode Voltage	V _{DD} = 2.3V, I _{IN} = -18mA	—	-0.7	-1.2	V
V _{IN}	DC Input Voltage		-0.3		+3.6	V
V _{IH}	DC Input HIGH ⁽²⁾		1.7		—	V
V _{IL}	DC Input LOW ⁽³⁾		—		0.7	V
V _{OH}	Output HIGH Voltage	I _{OH} = -12mA	V _{DD} - 0.4		—	V
		I _{OH} = -100μA	V _{DD} - 0.1		—	V
V _{OL}	Output LOW Voltage	I _{OL} = 12mA	—		0.4	V
		I _{OL} = 100μA	—		0.1	V

- NOTES:**
- See RECOMMENDED OPERATING RANGE table.
 - Voltage required to maintain a logic HIGH.
 - Voltage required to maintain a logic LOW.
 - Typical values are at V_{DD} = 2.5V, +25°C ambient.

POWER SUPPLY CHARACTERISTICS

Symbol	Parameter	Test Conditions ⁽¹⁾	Typ.	Max	Unit
I _{DDQ}	Quiescent V _{DD} Power Supply Current	V _{DD} = Max., Reference Clock = LOW Outputs enabled, All outputs unloaded	1.5	2	mA
I _{DDO}	Dynamic V _{DD} Power Supply Current per Output	V _{DD} = Max., V _{DD} = Max., C _L = 0pF	150	200	μA/MHz
I _{TOT}	Total Power V _{DD} Supply Current	V _{DD} = 2.5V., F _{REFERENCE CLOCK} = 100MHz, C _L = 15pF	70	90	mA
		V _{DD} = 2.5V., F _{REFERENCE CLOCK} = 200MHz, C _L = 15pF	100	150	

NOTE:

1. The termination resistors are excluded from these measurements.

INPUT AC TEST CONDITIONS

Symbol	Parameter	Value	Units
V _{IH}	Input HIGH Voltage	V _{DD}	V
V _{IL}	Input LOW Voltage	0	V
V _{TH}	Input Timing Measurement Reference Level ⁽¹⁾	V _{DD} /2	V
t _R , t _F	Input Signal Edge Rate ⁽²⁾	2	V/ns

NOTES:

1. A nominal 1.25V timing measurement reference level is specified to allow constant, repeatable results in an automatic test equipment (ATE) environment.
2. The input signal edge rate of 2V/ns or greater is to be maintained in the 10% to 90% range of the input waveform.

AC ELECTRICAL CHARACTERISTICS OVER OPERATING RANGE⁽⁴⁾

Symbol	Parameter	Min.	Typ.	Max	Unit
Skew Parameters					
t _{SK(O)}	Same Device Output Pin-to-Pin Skew ⁽¹⁾	—	—	25	ps
t _{SK(P)}	Pulse Skew ⁽²⁾	—	—	300	ps
t _{SK(PP)}	Part-to-Part Skew ⁽³⁾	—	—	300	ps
Propagation Delay					
t _{PLH} t _{PHL}	Propagation Delay A to Qn	—	—	2	ns
t _R	Output Rise Time (20% to 80%)	350	—	850	ps
t _F	Output Fall Time (20% to 80%)	350	—	850	ps
f _O	Frequency Range	—	—	200	MHz
Output Gate Enable/Disable Delay					
t _{PGE}	Output Gate Enable to Qn	—	—	3.5	ns
t _{PGD}	Output Gate Enable to Qn Driven to GL Designated Level	—	—	3	ns

NOTES:

1. Skew measured between all outputs under identical input and output transitions and load conditions on any one device.
2. Skew measured is the difference between propagation delay times t_{PHL} and t_{PLH} of any output under identical input and output transitions and load conditions on any one device.
3. Skew measured is the magnitude of the difference in propagation times between any outputs of two devices, given identical transitions and load conditions at identical V_{DD} levels and temperature.
4. Guaranteed by design.

AC TIMING WAVEFORMS

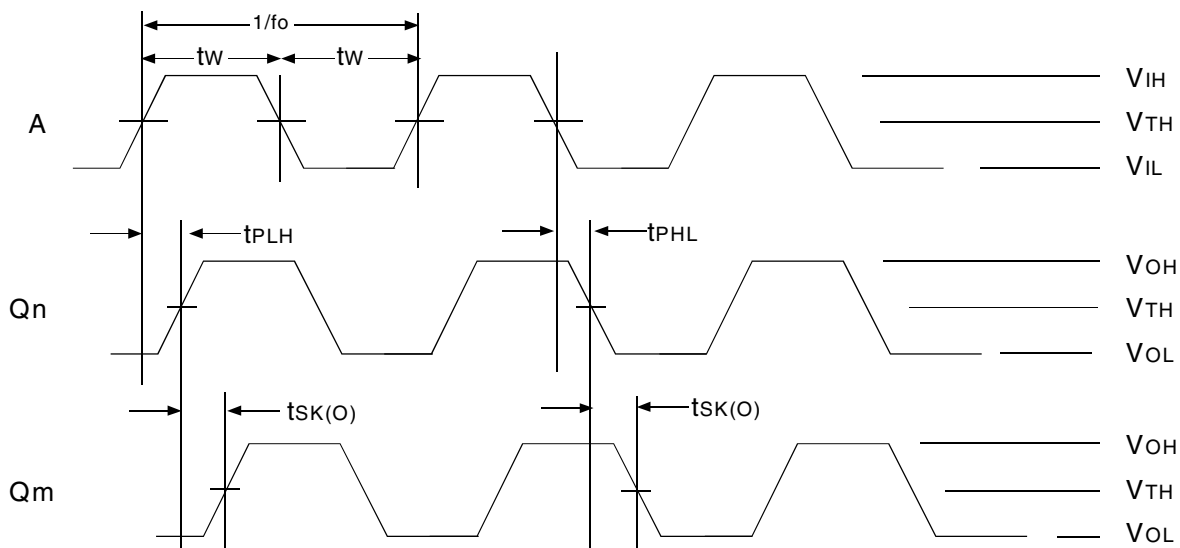

Propagation and Skew Waveforms

NOTE: Pulse Skew is calculated using the following expression:

$$t_{sk(p)} = |t_{PHL} - t_{PLH}|$$

where t_{PHL} and t_{PLH} are measured on the controlled edges of any one output from rising and falling edges of a single pulse. Please note that the t_{PHL} and t_{PLH} shown are not valid measurements for this calculation because they are not taken from the same pulse.

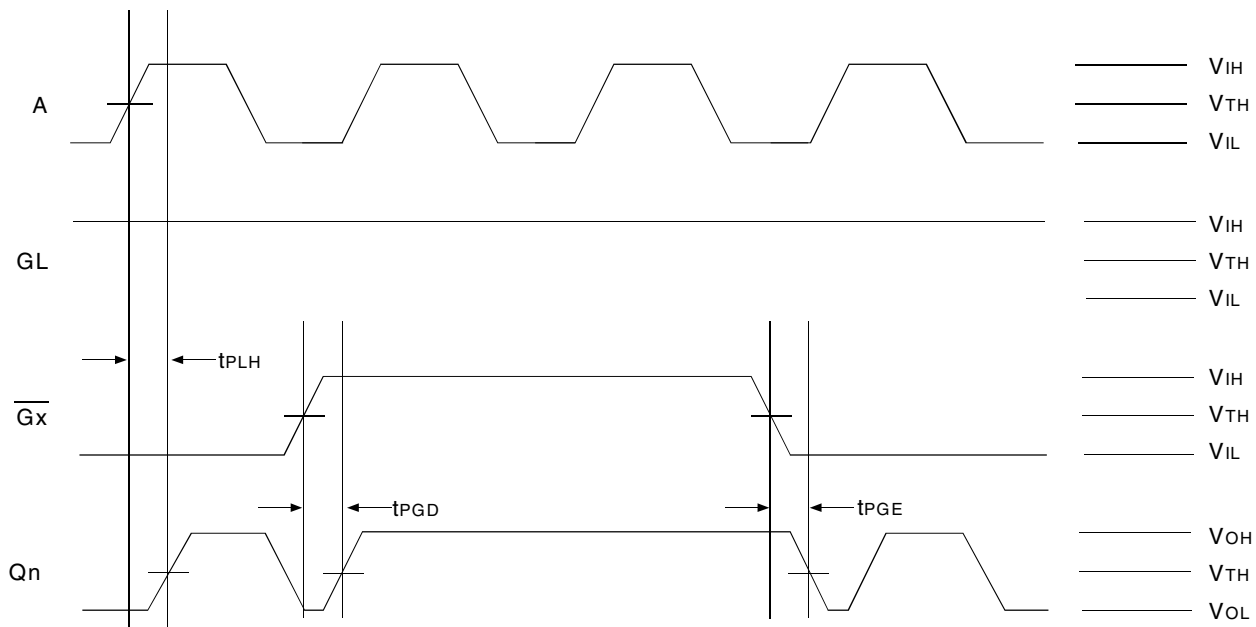

Gate Disable/Enable Runt Pulse Generation

NOTE:

As shown, it is possible to generate runt pulses on gate disable and enable of the outputs. It is the user's responsibility to time their $\overline{G_x}$ signals to avoid this problem.

TEST CIRCUIT AND CONDITIONS

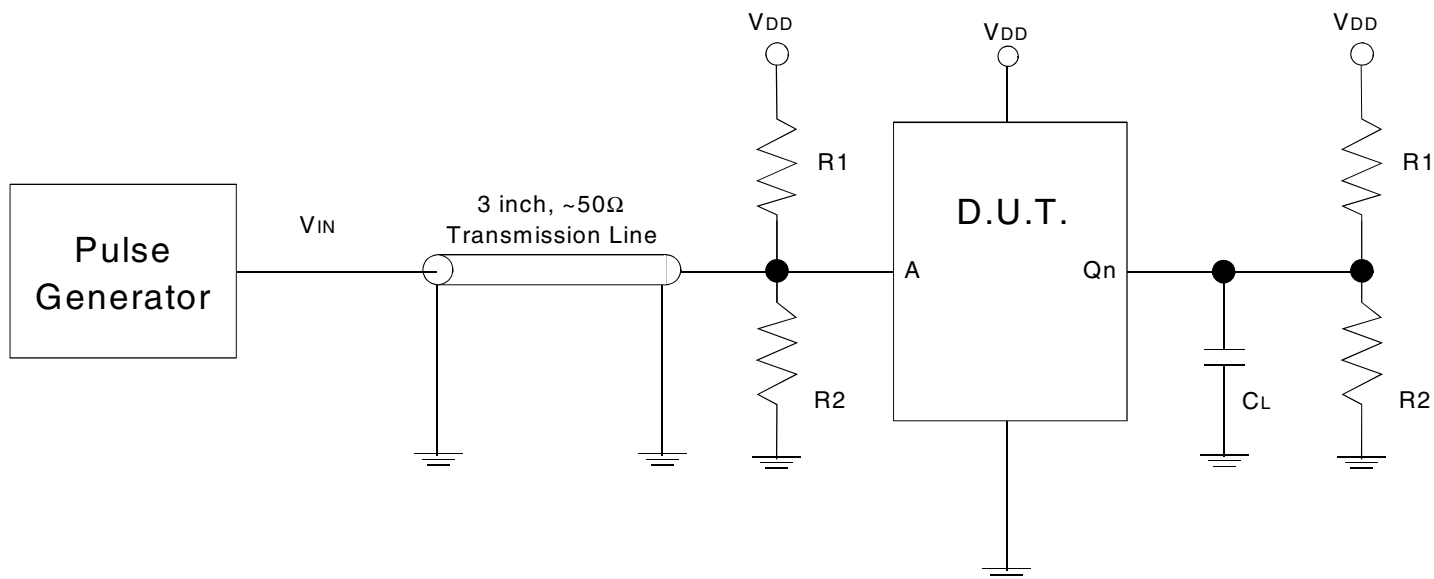

Test Circuit for Input/Output

INPUT/OUTPUT TEST CONDITIONS

Symbol	$V_{DD} = 2.5V \pm 0.2V$	Unit
V_{TH}	$V_{DD} / 2$	V
R1	100	Ω
R2	100	Ω
C_L	15	pF

ORDERING INFORMATION

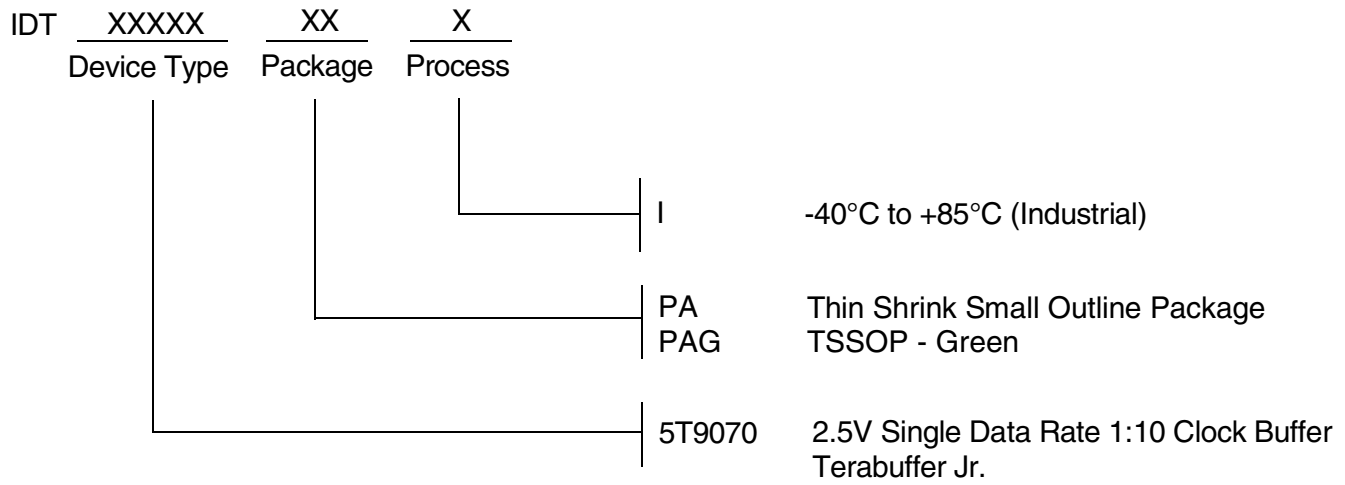

CORPORATE HEADQUARTERS
6024 Silver Creek Valley Road
San Jose, CA 95138

for SALES:
800-345-7015 or 408-284-8200
fax: 408-284-2775
www.idt.com

for Tech Support:
clockhelp@idt.com