



Frequency Generator for Transmeta™ Efficeon™

Recommended Application:

Transmeta Efficeon, ATi M6

Output Features:

- 3 - CPUs @ 3.3V including 1 free running CPUCLK_F
- 7 - PCI @ 3.3V, including 4 free running PCICLK_F
- 1 - 27MHz clock @ 3.3V
- 2 - 48MHz clocks @ 3.3V
- 2 - REF clocks @3.3V

Key Specifications:

- CPU output jitter: < 250ps
- PCI output skew: < 250ps
- CPUT - PCI output skew: 1-3ns
- 27MHz Accuracy < 50ppm
- 48MHz Accuracy < 50ppm

Features:

- Support I2C Index read/write and block read/write operations.
- Uses external 14.318MHz reference input or XTAL.
- Full Load Power consumption reduced >10% compared to reference device
- Power management via SMBus

Functionality

Byte 4b7	Byte 4b6	Byte 4b5	Spread	
			%	
0	0	0	+/-0.3	CENTER
0	0	1	+/-0.6	
0	1	0	+/-0.25	
0	1	1	+/-0.45	
1	0	0	-0.60%	DOWN
1	0	1	-1.20%	
1	1	0	-0.50%	
1	1	1	-0.90%	

Pin Configuration

VDDREF	1	48	REF1
REF0	2	47	VDDCPU
GNDREF	3	46	N/C
X1	4	45	GPUCLK0
X2	5	44	GNDCPU
VDDPCI	6	43	GPUCLK1
PCICLK_F0	7	42	GPUCLK_F
PCICLK_F1	8	41	CPU_STOP#
GNDPCI	9	40	GND
PCICLK0	10	39	N/C
PCICLK1	11	38	OE*
PCICLK_F2	12	37	N/C
PCICLK_F3	13	36	VDD
VDDPCI	14	35	N/C
PCICLK2	15	34	VDD27
GNDPCI	16	33	GND
N/C	17	32	27MHZ
N/C	18	31	N/C
VDDCOR	19	30	N/C
PCI_STOP#	20	29	N/C
**PD#	21	28	GND48
GND48	22	27	VDD48
SDATA	23	26	48MHZ_1
SCLK	24	25	48MHZ_0

48-TSSOP

* Internal Pull-Up Resistor

**No Diode Clamp to VDD



Pin Descriptions

PIN #	PIN NAME	PIN TYPE	DESCRIPTION
1	VDDREF	PWR	Ref. XTAL power supply, nominal 3.3V
2	REF0	OUT	14.318 MHz reference clock.
3	GNDREF	PWR	Ground pin for the REF outputs.
4	X1	IN	Crystal input, Nominally 14.318MHz.
5	X2	OUT	Crystal output, Nominally 14.318MHz
6	VDDPCI	PWR	Power supply for PCI clocks, nominal 3.3V
7	PCICLK_F0	OUT	Free running PCI clock not affected by PCI_STOP#.
8	PCICLK_F1	OUT	Free running PCI clock not affected by PCI_STOP#.
9	GNDPCI	PWR	Ground pin for the PCI outputs
10	PCICLK0	OUT	PCI clock output.
11	PCICLK1	OUT	PCI clock output.
12	PCICLK_F2	OUT	Free running PCI clock not affected by PCI_STOP#.
13	PCICLK_F3	OUT	Free running PCI clock not affected by PCI_STOP#.
14	VDDPCI	PWR	Power supply for PCI clocks, nominal 3.3V
15	PCICLK2	OUT	PCI clock output.
16	GNDPCI	PWR	Ground pin for the PCI outputs
17	N/C	N/C	No Connection.
18	N/C	N/C	No Connection.
19	VDDCOR	PWR	3.3V power for the PLL core.
20	PCI_STOP#	IN	Stops all PCICLKs at logic 0 level, when low. Free running PCICLKs are not effected by this input.
21	**PD#	IN	Asynchronous active low input pin, with 120Kohm internal pull-up resistor, used to power down the device. The internal clocks are disabled and the VCO and the crystal are stopped.
22	GND48	PWR	Ground pin for the 48MHz outputs
23	SDATA	I/O	Data pin for SMBus circuitry, 5V tolerant.
24	SCLK	IN	Clock pin of SMBus circuitry, 5V tolerant.
25	48MHZ_0	OUT	48MHz clock output.
26	48MHZ_1	OUT	48MHz clock output.
27	VDD48	PWR	Power pin for the 48MHz output.3.3V
28	GND48	PWR	Ground pin for the 48MHz outputs
29	N/C	N/C	No Connection.
30	N/C	N/C	No Connection.
31	N/C	N/C	No Connection.
32	27MHZ	OUT	27.0000MHz Video Clock for ATi Chipset
33	GND	PWR	Ground pin.
34	VDD27	PWR	Power pin for the 27MHz output.3.3V
35	N/C	N/C	No Connection.
36	VDD	PWR	Power supply, nominal 3.3V
37	N/C	N/C	No Connection.
38	OE*	IN	Active high input for enabling Memory Channel outputs. 0 = tri-state outputs, 1= enable outputs
39	N/C	N/C	No Connection.
40	GND	PWR	Ground pin.
41	CPU_STOP#	IN	Stops all CPUCLK, except those set to be free running clocks
42	CPUCLK_F	OUT	Free running CPU clock. Not affected by the CPU_STOP#.
43	CPUCLK1	OUT	CPU clock outputs. 3.3V
44	GNDCPU	PWR	Ground pin for the CPU outputs
45	CPUCLK0	OUT	CPU clock outputs. 3.3V
46	N/C	N/C	No Connection.
47	VDDCPU	PWR	Supply for CPU clocks, 3.3V nominal
48	REF1	OUT	14.318 MHz reference clock.

* Internal Pull-Up Resistor

** No diode clamp to VDD.



General Description

Spread spectrum may be enabled through SMBus programming. Spread spectrum typically reduces system EMI by 8dB to 10dB. This simplifies EMI qualification without resorting to board design iterations or costly shielding. The ICS952302 employs a proprietary closed loop design, which tightly controls the percentage of spreading over process and temperature variations.

Block Diagram

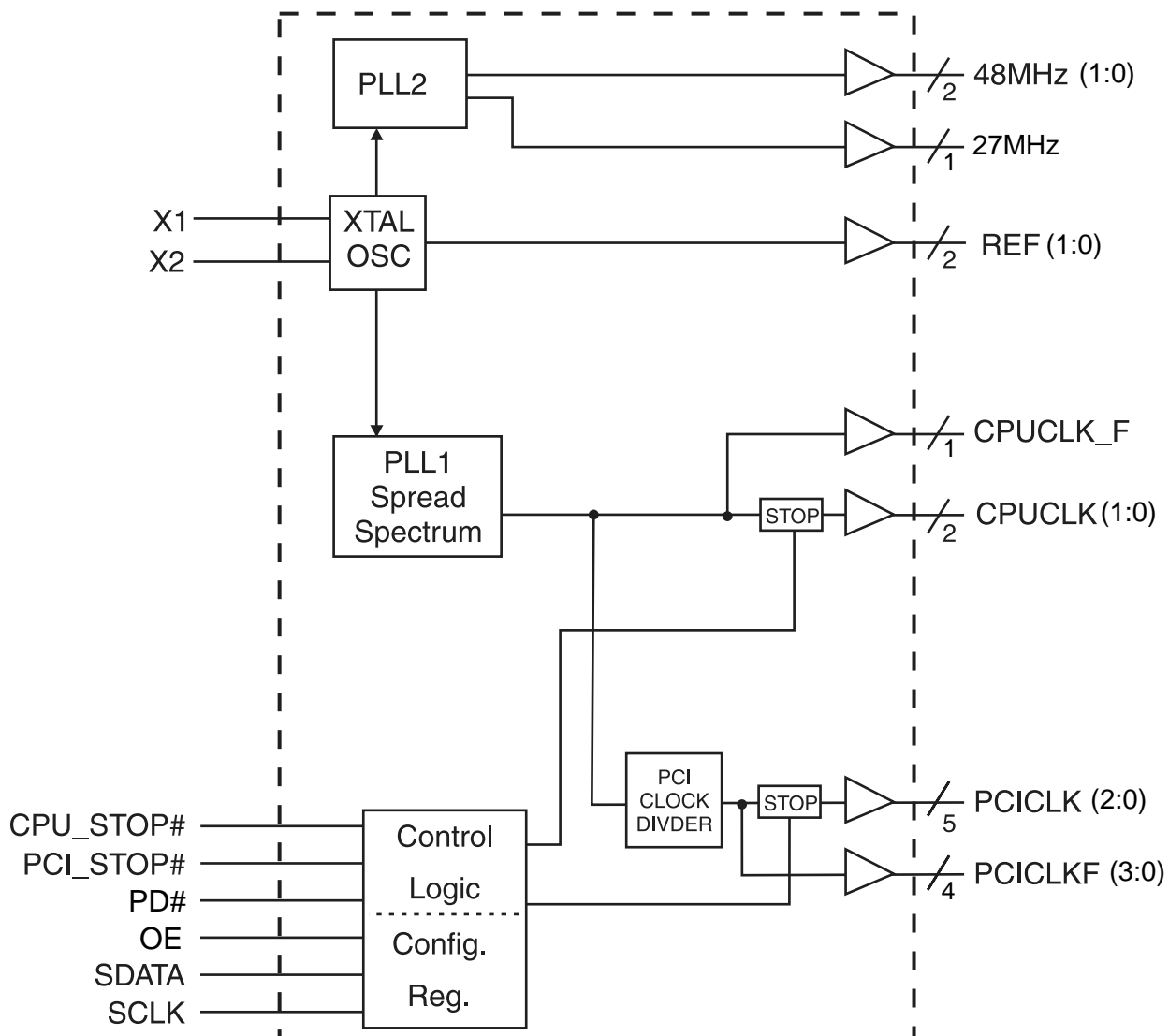



SMBus Table: Output Control Register

Byte 0	Pin #	Name	Control	Type	0	1	PWD
			Function				
Bit 7	42	CPUCLK_F	Output Enable	RW	Disable	Enable	1
Bit 6	45	CPUCLK0	Output Enable	RW	Disable	Enable	1
Bit 5	43	CPUCLK1	Output Enable	RW	Disable	Enable	1
Bit 4	32	27MHZ	Output Enable	RW	Disable	Enable	1
Bit 3	25	48MHZ_0	Output Enable	RW	Disable	Enable	1
Bit 2	26	48MHZ_1	Output Enable	RW	Disable	Enable	1
Bit 1	2	REF0	Output Enable	RW	Disable	Enable	1
Bit 0	48	REF1	Output Enable	RW	Disable	Enable	1

SMBus Table: Output Control Register

Byte 1	Pin #	Name	Control	Type	0	1	PWD
			Function				
Bit 7	7	PCICLK_F0	Test Mode	RW	Disable	Enable	1
Bit 6	8	PCICLK_F1	Output Enable	RW	Disable	Enable	1
Bit 5	12	PCICLK_F2	Output Enable	RW	Disable	Enable	1
Bit 4	13	PCICLK_F3	Output Enable	RW	Disable	Enable	1
Bit 3	10	PCICLK0	Spread Control	RW	Disable	Enable	1
Bit 2	11	PCICLK1	Output Enable	RW	Disable	Enable	1
Bit 1	15	PCICLK2	Output Enable	RW	Disable	Enable	1
Bit 0	-	Spread Spectrum Mode	Spread Control for PLL1	RW	OFF	ON	0

SMBus Table: Output Control Register

Byte 2	Pin #	Name	Control	Type	0	1	PWD
			Function				
Bit 7	42	CPUCLK_F	Allow assertion of CPU_STOP# or setting of CPU_STOP control bit in SMBus register to stop CPU clocks	RW	Free Running	Stoppable	0
Bit 6	45	CPUCLK0		RW	Free Running	Stoppable	1
Bit 5	43	CPUCLK1		RW	Free Running	Stoppable	1
Bit 4	-	Reserved	Reserved	RW	-	-	x
Bit 3	-	Reserved	Reserved	RW	-	-	x
Bit 2	(note)	CPU_STOP	Stop all CPU clocks	RW	Enable	Disable	1
Bit 1	-	Reserved	Reserved	RW	-	-	x
Bit 0	20, 41	CPU_STOP# PCI_STOP#	H/w or S/w Select	RW	H/W	I2C	1

Note: Byte2bit2=0 (Enable) to stop all CPUCLK's ONLY when Byte2 bit(5:7) at STOPPABLE MODE

SMBus Table: Output Control Register

Byte 3	Pin #	Name	Control	Type	0	1	PWD
			Function				
Bit 7	7	PCICLK_F0	Allow assertion of PCI_STOP# or setting of PCI_STOP control bit in SMBus register to stop PCI clocks	RW	Free Running	Stoppable	0
Bit 6	8	PCICLK_F1		RW	Free Running	Stoppable	0
Bit 5	12	PCICLK_F2		RW	Free Running	Stoppable	0
Bit 4	13	PCICLK_F3		RW	Free Running	Stoppable	0
Bit 3	10	PCICLK0		RW	Free Running	Stoppable	1
Bit 2	11	PCICLK1		RW	Free Running	Stoppable	1
Bit 1	15	PCICLK2		RW	Free Running	Stoppable	1
Bit 0	-	PCI_STOP	Stop all PCI clocks	RW	Enable	Disable	1



SMBus Table: Spread Spectrum Control Register

Byte 4	Pin #	Name	Control Function	Type	0	1	PWD
Bit 7	-	Spread Position	Center or Down SS	RW	Center	Down	1
Bit 6	-	SS1	Spread Bit 1	RW	See SS Table		0
Bit 5	-	SS2	Spread Bit 2	RW			0
Bit 4	-	Reserved					-
Bit 3	-	Reserved					-
Bit 2	-	Reserved					-
Bit 1	-	Reserved					-
Bit 0	-	Reserved					-

SMBus Table: Control Register

Byte 5	Pin #	Name	Control Function	Type	0	1	PWD
Bit 7	-	Reserved					-
Bit 6	-	Reserved					-
Bit 5	-	Reserved					-
Bit 4	-	Reserved					-
Bit 3	-	Reserved					-
Bit 2	-	Reserved					-
Bit 1	-	Reserved					-
Bit 0	-	Reserved					-

SMBus Table: Control Register

Byte 6	Pin #	Name	Control Function	Type	0	1	PWD
Bit 7	-	Reserved					-
Bit 6	-	Reserved					-
Bit 5	-	Reserved					-
Bit 4	-	Reserved					-
Bit 3	-	Reserved					-
Bit 2	-	Reserved					-
Bit 1	-	Reserved					-
Bit 0	-	Reserved					-

SMBus Table: Vendor & Revision ID Register

Byte 7	Pin #	Name	Control Function	Type	0	1	PWD
Bit 7	-	RID3	REVISION ID	R	-	-	x
Bit 6	-	RID2		R	-	-	x
Bit 5	-	RID1		R	-	-	x
Bit 4	-	RID0		R	-	-	x
Bit 3	-	VID3	VENDOR ID	R	-	-	0
Bit 2	-	VID2		R	-	-	0
Bit 1	-	VID1		R	-	-	0
Bit 0	-	VID0		R	-	-	1



Absolute Maximum Ratings

Supply Voltage	5.5 V
Logic Inputs	GND -0.5 V to $V_{DD} + 0.5$ V
Ambient Operating Temperature	0°C to +70°C
Case Temperature	115°C
Storage Temperature	-65°C to +150°C

Stresses above those listed under *Absolute Maximum Ratings* may cause permanent damage to the device. These ratings are stress specifications only and functional operation of the device at these or any other conditions above those listed in the operational sections of the specifications is not implied. Exposure to absolute maximum rating conditions for extended periods may affect product reliability.

Electrical Characteristics - Input/Supply/Common Output Parameters

$T_A = 0 - 70^\circ\text{C}$; Supply Voltage $V_{DD} = 3.3$ V +/-5% (unless otherwise stated)

PARAMETER	SYMBOL	CONDITIONS	MIN	TYP	MAX	UNITS
Input High Voltage	V_{IH}		2		$V_{DD} + 0.3$	V
Input Low Voltage	V_{IL}		$V_{SS} - 0.3$		0.8	V
Input High Current	I_{IH}	$V_{IN} = V_{DD}$			5	mA
Input Low Current	I_{IL1}	$V_{IN} = 0$ V; Inputs with no pull-up resistors	-5			mA
Input Low Current	I_{IL2}	$V_{IN} = 0$ V; Inputs with pull-up resistors	-200			mA
Operating Supply Current	$I_{DD(OP)}$	$C_L =$ (full load); 66MHz		102	150	mA
Power Down Supply Current	I_{DDPD}	$C_L = 0$ pF; With input address to Vdd or GND		320	600	µA
Input frequency	F_i	$V_{DD} = 3.3$ V;	11	14.3132	16	MHz
Input Capacitance ¹	C_{IN}	Logic Inputs			5	pF
	C_{INX}	X1 & X2 pins	27		45	pF
Clk Stabilization ¹	T_{STAB}	From $V_{DD} = 3.3$ V to 1% target Freq.		3	5.5	ms
Skew ¹	$T_{CPU-PCI}$	$V_T = 1.5$ V	1	1.5	4	ns

¹Guaranteed by design, not 100% tested in production.



Electrical Characteristics - CPU

T_A = 0 - 70°C; V_{DD} = 3.3 V +/-5%; C_L = 10 - 20 pF (unless otherwise stated)

PARAMETER	SYMBOL	CONDITIONS	MIN	TYP	MAX	UNITS
Output High Voltage	V _{OH2B}	I _{OH} = -20 mA	2.4	2.9		V
Output Low Voltage	V _{OL2B}	I _{OL} = 12 mA		0.25	0.4	V
Output High Current	I _{OH2B}	V _{OUT} = 1 V		-67	-29	mA
		V _{OUT} = 3.135V	-23	-8		
Output Low Current	I _{OL2B}	V _{OUT} = 1.95 V	27	56		mA
		V _{OUT} = 0.4V		23	30	
Rise Time ¹	t _{r2B}	V _{OL} = 0.4 V, V _{OH} = 2.4 V	1	1.4	2	ns
Fall Time ¹	t _{f2B}	V _{OH} = 2.4 V, V _{OL} = 0.4 V	1	1.4	2	ns
Duty Cycle ¹	d _{I2B}	V _T = 1.5 V	45	51.5	55	%
Skew ¹	t _{sk2B}	V _T = 1.5 V		60	175	ps
Jitter, Cycle-to-cycle ¹	t _{j_{cyc-cyc2B}}	V _T = 1.5 V		175	250	ps

¹Guaranteed by design, not 100% tested in production.

Electrical Characteristics - PCICLK, PCICLK_F

T_A = 0 - 70°C; V_{DD} = 3.3 V +/-5%; C_L = 10 - 20 pF (unless otherwise stated)

PARAMETER	SYMBOL	CONDITIONS	MIN	TYP	MAX	UNITS
Output High Voltage	V _{OH2B}	I _{OH} = -20 mA	2.4	2.9		V
Output Low Voltage	V _{OL2B}	I _{OL} = 12 mA		0.25	0.4	V
Output High Current	I _{OH2B}	V _{OUT} = 1 V		-67	-29	mA
		V _{OUT} = 3.135V	-23	-8		
Output Low Current	I _{OL2B}	V _{OUT} = 1.95 V	27	56		mA
		V _{OUT} = 0.4V		23	30	
Rise Time ¹	t _{r2B}	V _{OL} = 0.4 V, V _{OH} = 2.4 V	1	1.3	2	ns
Fall Time ¹	t _{f2B}	V _{OH} = 2.4 V, V _{OL} = 0.4 V	1	1.2	2	ns
Duty Cycle ¹	d _{I2B}	V _T = 1.5 V	45	50.5	55	%
Skew ¹	t _{sk2B}	V _T = 1.5 V		68	250	ps
Jitter, Cycle-to-cycle ¹	t _{j_{cyc-cyc2B}}	V _T = 1.5 V		100	250	ps

¹Guaranteed by design, not 100% tested in production.



Electrical Characteristics - 27MHz

$T_A = 0 - 70^\circ\text{C}$; $V_{DD} = 3.3\text{ V} \pm 5\%$; $C_L = 10 - 20\text{ pF}$ (unless otherwise stated)

PARAMETER	SYMBOL	CONDITIONS	MIN	TYP	MAX	UNITS
Frequency Accuracy	F_{ACC}	REF Out = 14.31818MHz	-50	0	50	ppm
Output High Voltage	V_{OH2B}	$I_{OH} = -20\text{ mA}$	2.4	2.9		V
Output Low Voltage	V_{OL2B}	$I_{OL} = 12\text{ mA}$		0.25	0.4	V
Output High Current	I_{OH2B}	$V_{OUT} = 1\text{ V}$		-67	-29	mA
		$V_{OUT} = 3.135\text{ V}$	-23	-8		
Output Low Current	I_{OL2B}	$V_{OUT} = 1.95\text{ V}$	27	56		mA
		$V_{OUT} = 0.4\text{ V}$		23	30	
Rise Time ¹	t_{r2B}	$V_{OL} = 0.4\text{ V}$, $V_{OH} = 2.4\text{ V}$	1	1.1	2	ns
Fall Time ¹	t_{f2B}	$V_{OH} = 2.4\text{ V}$, $V_{OL} = 0.4\text{ V}$	1	1.2	2	ns
Duty Cycle ¹	d_{f2B}	$V_T = 1.5\text{ V}$	45	51	55	%
Jitter, Cycle-to-cycle ¹	$t_{jcy-cyc2B}$	$V_T = 1.5\text{ V}$		340	400	ps

¹Guaranteed by design, not 100% tested in production.

Electrical Characteristics - 48MHz

$T_A = 0 - 70^\circ\text{C}$; $V_{DD} = 3.3\text{ V} \pm 5\%$; $C_L = 10 - 20\text{ pF}$ (unless otherwise stated)

PARAMETER	SYMBOL	CONDITIONS	MIN	TYP	MAX	UNITS
Frequency Accuracy	F_{ACC}	REF Out = 14.31818MHz	-50	0	50	ppm
Output High Voltage	V_{OH2B}	$I_{OH} = -20\text{ mA}$	2.4	2.9		V
Output Low Voltage	V_{OL2B}	$I_{OL} = 12\text{ mA}$		0.25	0.4	V
Output High Current	I_{OH2B}	$V_{OUT} = 1\text{ V}$		-67	-29	mA
		$V_{OUT} = 3.135\text{ V}$	-23	-8		
Output Low Current	I_{OL2B}	$V_{OUT} = 1.95\text{ V}$	27	56		mA
		$V_{OUT} = 0.4\text{ V}$		23	30	
Rise Time ¹	t_{r2B}	$V_{OL} = 0.4\text{ V}$, $V_{OH} = 2.4\text{ V}$	1	1.1	2	ns
Fall Time ¹	t_{f2B}	$V_{OH} = 2.4\text{ V}$, $V_{OL} = 0.4\text{ V}$	1	1.5	2	ns
Duty Cycle ¹	d_{f2B}	$V_T = 1.5\text{ V}$	45	52	55	%
Jitter, Cycle-to-cycle ¹	$t_{jcy-cyc2B}$	$V_T = 1.5\text{ V}$		200	350	ps

¹Guaranteed by design, not 100% tested in production.



Electrical Characteristics - REF

$T_A = 0 - 70^{\circ}\text{C}$; $V_{DD} = 3.3\text{ V} \pm 5\%$; $C_L = 10 - 30\text{ pF}$ (unless otherwise stated)

PARAMETER	SYMBOL	CONDITIONS	MIN	TYP	MAX	UNITS
Frequency Accuracy	F_{ACC}	REF Out = 14.31818MHz	-50	0	50	ppm
Output High Voltage	V_{OH2B}	$I_{OH} = -20\text{ mA}$	2.4	2.9		V
Output Low Voltage	V_{OL2B}	$I_{OL} = 12\text{ mA}$		0.25	0.4	V
Output High Current	I_{OH2B}	$V_{OUT} = 1\text{ V}$		-67	-29	mA
		$V_{OUT} = 3.135\text{V}$	-23	-8		
Output Low Current	I_{OL2B}	$V_{OUT} = 1.95\text{ V}$	27	56		mA
		$V_{OUT} = 0.4\text{V}$		23	30	
Rise Time ¹	t_{r2B}	$V_{OL} = 0.4\text{ V}, V_{OH} = 2.4\text{ V}$	1	1.3	2	ns
Fall Time ¹	t_{f2B}	$V_{OH} = 2.4\text{ V}, V_{OL} = 0.4\text{ V}$	1	1.7	2	ns
Duty Cycle ¹	d_{f2B}	$V_T = 1.5\text{ V}$	45	53	55	%
Jitter, Cycle-to-cycle ¹	$t_{jyc-cyc2B}$	$V_T = 1.5\text{ V}$		270	500	ps

¹Guaranteed by design, not 100% tested in production.



General SMBus serial interface information for the ICS952302

How to Write:

- Controller (host) sends a start bit.
- Controller (host) sends the write address $D2_{(H)}$
- ICS clock will **acknowledge**
- Controller (host) sends the beginning byte location = N
- ICS clock will **acknowledge**
- Controller (host) sends the data byte count = X
- ICS clock will **acknowledge**
- Controller (host) starts sending **Byte N through Byte N + X - 1** (see Note 2)
- ICS clock will **acknowledge** each byte **one at a time**
- Controller (host) sends a Stop bit

How to Read:

- Controller (host) will send start bit.
- Controller (host) sends the write address $D2_{(H)}$
- ICS clock will **acknowledge**
- Controller (host) sends the beginning byte location = N
- ICS clock will **acknowledge**
- Controller (host) will send a separate start bit.
- Controller (host) sends the read address $D3_{(H)}$
- ICS clock will **acknowledge**
- ICS clock will send the data byte count = X
- ICS clock sends **Byte N + X - 1**
- ICS clock sends **Byte 0 through byte X**
- Controller (host) will need to acknowledge each byte
- Controller (host) will send a not acknowledge bit
- Controller (host) will send a stop bit

Index Block Write Operation		
Controller (Host)		ICS (Slave/Receiver)
T	starT bit	
Slave Address $D2_{(H)}$		
WR	WRite	
Beginning Byte = N		ACK
Data Byte Count = X		ACK
Beginning Byte N		X Byte
	○	
	○	
	○	
	○	
Byte N + X - 1		ACK
P	stoP bit	

Index Block Read Operation		
Controller (Host)		ICS (Slave/Receiver)
T	starT bit	
Slave Address $D2_{(H)}$		
WR	WRite	
Beginning Byte = N		ACK
Repeat starT		ACK
Slave Address $D3_{(H)}$		
RD	ReaD	ACK
Data Byte Count = X		
ACK		X Byte
ACK		
	○	
	○	
	○	
Byte N + X - 1		
N	Not acknowledge	
P	stoP bit	

Shared Pin Operation - Input/Output Pins

The I/O pins designated by (input/output) serve as dual signal functions to the device. During initial power-up, they act as input pins. The logic level (voltage) that is present on these pins at this time is read and stored into a 5-bit internal data latch. At the end of Power-On reset, (see AC characteristics for timing values), the device changes the mode of operations for these pins to an output function. In this mode the pins produce the specified buffered clocks to external loads.

To program (load) the internal configuration register for these pins, a resistor is connected to either the VDD (logic 1) power supply or the GND (logic 0) voltage potential. A 10 Kilohm (10K) resistor is used to provide both the solid CMOS programming voltage needed during the power-up programming period and to provide an insignificant load on the output clock during the subsequent operating period.

Figure 1 shows a means of implementing this function when a switch or 2 pin header is used. With no jumper is installed the pin will be pulled high. With the jumper in place the pin will be pulled low. If programmability is not necessary, than only a single resistor is necessary. The programming resistors should be located close to the series termination resistor to minimize the current loop area. It is more important to locate the series termination resistor close to the driver than the programming resistor.

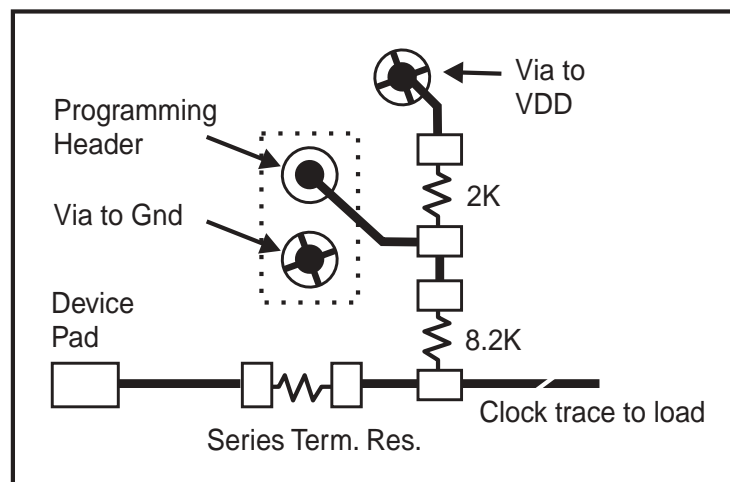

Fig. 1



PD# Timing Diagram

The power down selection is used to put the part into a very low power state without turning off the power to the part. PD# is an asynchronous active low input. This signal needs to be synchronized internal to the device prior to powering down the clock synthesizer.

Internal clocks are not running after the device is put in power down. When PD# is active low all clocks need to be driven to a low value and held prior to turning off the VCOs and crystal. The power up latency needs to be less than 4 mS. The power down latency should be as short as possible but conforming to the sequence requirements shown below. PCI_STOP# and CLK_STOP# are considered to be don't cares during the power down operations. The REF and 48MHz clocks are expected to be stopped in the LOW state as soon as possible. Due to the state of the internal logic, stopping and holding the REF clock outputs in the LOW state may require more than one clock cycle to complete.

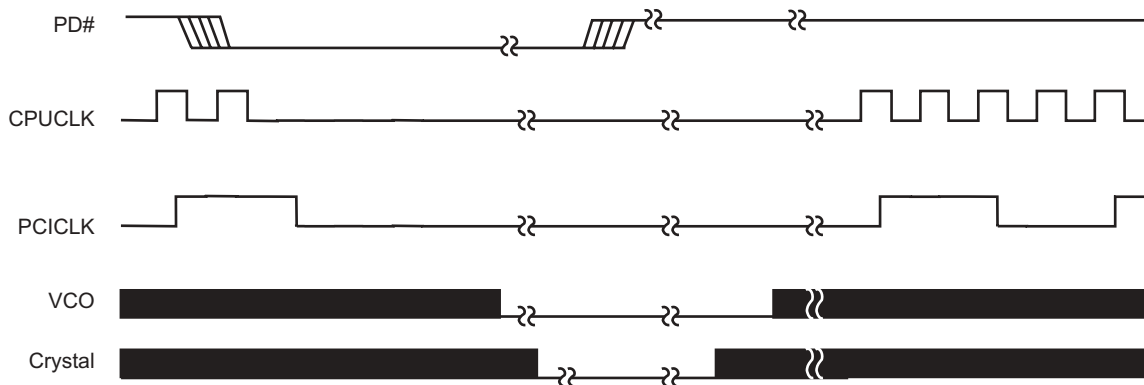

Notes:

1. All timing is referenced to the Internal CPUCLK (defined as inside the ICS952302 device).
2. As shown, the outputs Stop Low on the next falling edge after PD# goes low.
3. PD# is an asynchronous input and metastable conditions may exist. This signal is synchronized inside this part.
4. The shaded sections on the VCO and the Crystal signals indicate an active clock.



CLK_STOP# Timing Diagram

CLK_STOP# is an asynchronous input to the clock synthesizer. It is used to turn off the CPU clocks for low power operation. CLK_STOP# is synchronized by the ICS952302. The minimum that the CPU clock is enabled (CLK_STOP# high pulse) is 100 CPU clocks. All other clocks will continue to run while the CPU clocks are disabled. The CPU clocks will always be stopped in a low state and start in such a manner that guarantees the high pulse width is a full pulse. CPU clock on latency is less than 4 CPU clocks and CPU clock off latency is less than 4 CPU clocks.

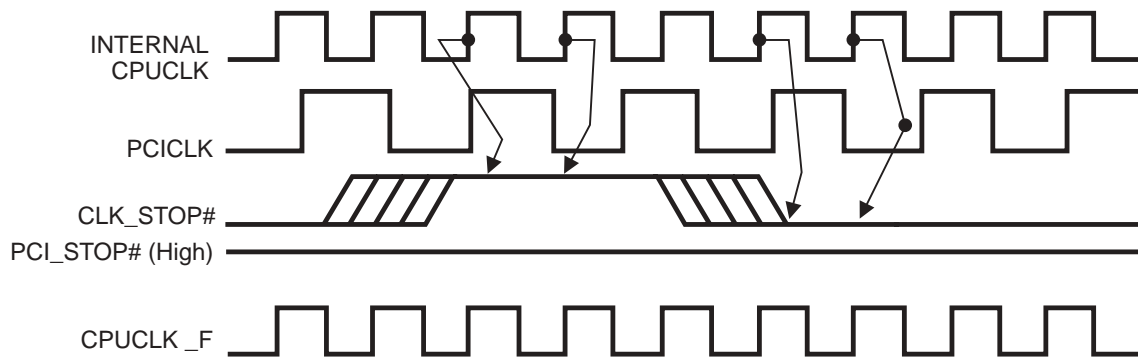

Notes:

1. All timing is referenced to the internal CPU clock.
2. CLK_STOP# is an asynchronous input and metastable conditions may exist. This signal is synchronized to the CPU clocks inside the ICS952302.
3. CLK_STOP# signal.
4. All other clocks continue to run undisturbed.



PCI_STOP# Timing Diagram

PCI_STOP# is an asynchronous input to the ICS952302. It is used to turn off the PCICLK clocks for low power operation. PCI_STOP# is synchronized by the ICS952302 internally. The minimum that the PCICLK clocks are enabled (PCI_STOP# high pulse) is at least 10 PCICLK clocks. PCICLK clocks are stopped in a low state and started with a full high pulse width guaranteed. PCICLK clock on latency cycles are only three rising PCICLK clocks, off latency is one PCICLK clock.

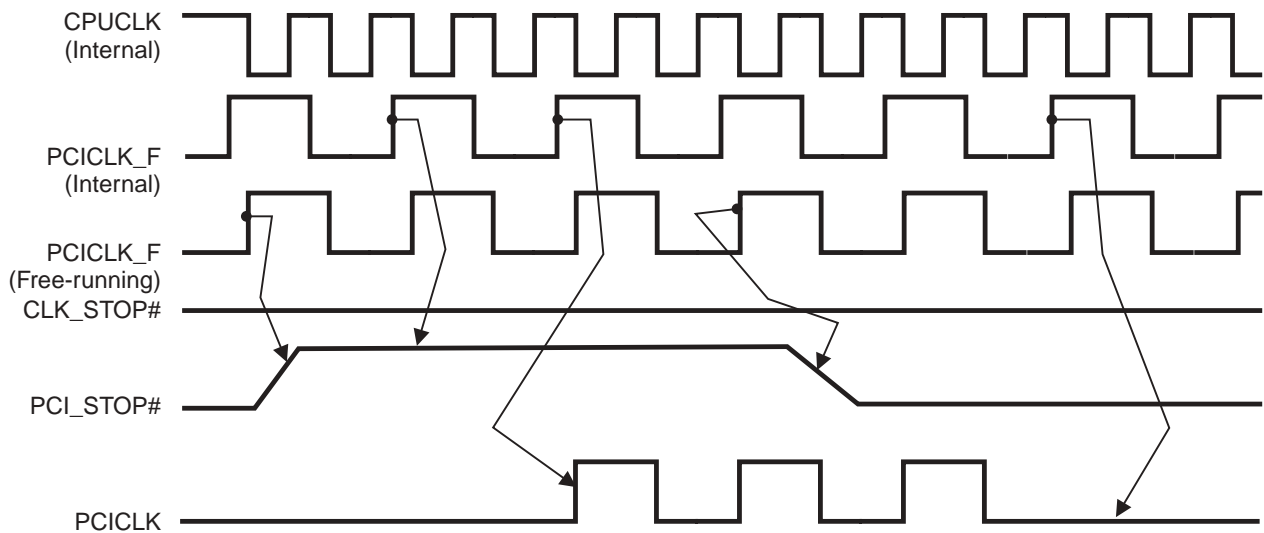

Notes:

1. All timing is referenced to the Internal CPUCLK (defined as inside the ICS952302 device.)
2. PCI_STOP# is an asynchronous input, and metastable conditions may exist. This signal is required to be synchronized inside the ICS952302.
3. All other clocks continue to run undisturbed.
4. CLK_STOP# is shown in a high (true) state.

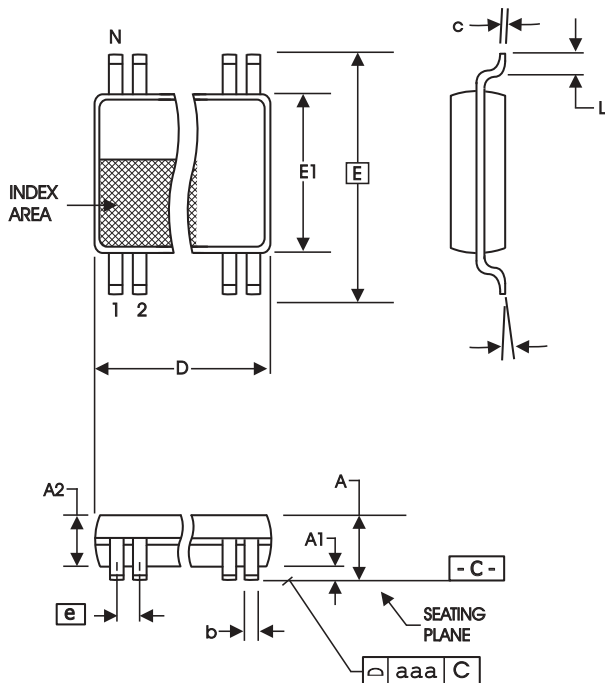

(240 mil) (0.020 mil)
6.10 mm. Body, 0.50 mm. pitch TSSOP

SYMBOL	In Millimeters		In Inches	
	COMMON DIMENSIONS	COMMON DIMENSIONS	COMMON DIMENSIONS	COMMON DIMENSIONS
	MIN	MAX	MIN	MAX
A	--	1.20	--	.047
A1	0.05	0.15	.002	.006
A2	0.80	1.05	.032	.041
b	0.17	0.27	.007	.011
c	0.09	0.20	.0035	.008
D	SEE VARIATIONS		SEE VARIATIONS	
E	8.10 BASIC		0.319 BASIC	
E1	6.00	6.20	.236	.244
e	0.50 BASIC		0.020 BASIC	
L	0.45	0.75	.018	.030
N	SEE VARIATIONS		SEE VARIATIONS	
α	0°	8°	0°	8°
aaa	--	0.10	--	.004

VARIATIONS

N	D mm.		D (inch)	
	MIN	MAX	MIN	MAX
48	12.40	12.60	.488	.496

Reference Doc.: JEDEC Publication 95, MO-153
10-0039

Ordering Information

ICS952302yGLF-T

Example:

ICS XXXX y G LF-T

