

## GENERAL DESCRIPTION



The ICS87604I is a 1:4 PCI/PCI-X Clock Generator. The ICS87604I has a selectable REF\_IN or crystal input. The REF\_IN input accepts LVCMOS or LVTTTL input levels. The ICS87604I has a fully integrated PLL along with frequency configurable clock and feedback outputs for multiply-ing and regenerating clocks with “zero delay”. The PLL’s VCO has an operating range of 250MHz - 500MHz, allowing this device to be used in a variety of general purpose clocking applications. For PCI/PCI-X applications in particular, the VCO frequency should be set to 400MHz. This can be accomplished by supplying 33.33MHz, 25MHz, 20MHz, or 16.66MHz on the reference clock or crystal input and by selecting ÷12, ÷16, ÷20, or ÷24, respectively as the feedback divide value. The divider on the output bank can then be configured to generate 33.33MHz (÷12), 66.66MHz (÷6), 100MHz (÷4), or 133.33MHz (÷3).

The ICS87604I is characterized to operate with its core supply at 3.3V and the bank supply at 3.3V or 2.5V. The ICS87604I is packaged in a small 6.1mm x 9.7mm TSSOP body, making it ideal for use in space-constrained applications.

## BLOCK DIAGRAM

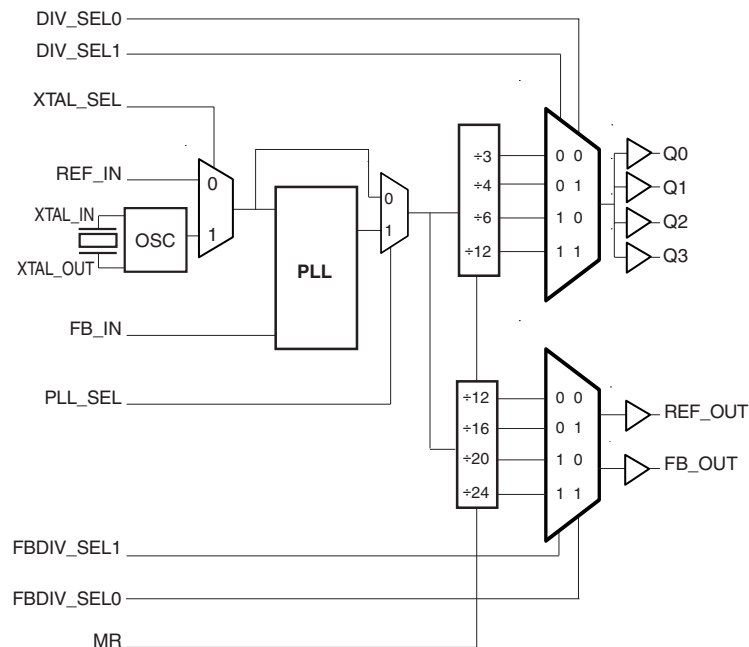

## FEATURES

- Fully integrated PLL
- Four LVCMOS/LVTTTL outputs, 15Ω typical output impedance
- Selectable crystal oscillator interface or LVCMOS/LVTTTL REF\_IN clock input
- Maximum output frequency: 166.67MHz
- Maximum crystal input frequency: 38MHz
- Maximum REF\_IN input frequency: 41.67MHz
- Individual banks with selectable output dividers for generating 33.33MHz, 66.66MHz, 100MHz and 133.33MHz
- Separate feedback control for generating PCI / PCI-X frequencies from a 16.66MHz or 20MHz crystal, or 25MHz or 33.33MHz reference frequency
- VCO range: 250MHz to 500MHz
- Cycle-to-cycle jitter: 120ps (maximum)
- Period jitter, RMS: 20ps (maximum)
- Output skew: 65ps (maximum)
- Static phase offset: 160ps ± 160ps
- Voltage Supply Modes:
  - $V_{DD}/V_{DDA}/V_{DDO}$   
3.3/3.3/3.3
  - 3.3/3.3/2.5
- -40°C to 85°C ambient operating temperature
- Available in both standard (RoHS 5 and lead-free (RoHS 6) packages

## PIN ASSIGNMENT

V <sub>DD</sub>	1	28	FBDIV_SEL1
FB_IN	2	27	FBDIV_SEL0
GND	3	26	DIV_SEL1
FB_OUT	4	25	DIV_SEL0
REF_OUT	5	24	nc
V <sub>DDO</sub>	6	23	MR
Q3	7	22	nc
Q2	8	21	GND
GND	9	20	GND
Q1	10	19	nc
Q0	11	18	REF_IN
V <sub>DDO</sub>	12	17	XTAL_OUT
PLL_SEL	13	16	XTAL_IN
V <sub>DDA</sub>	14	15	XTAL_SEL

**ICS87604I**  
**28-Lead TSSOP, 240MIL**  
 6.1mm x 9.7mm x 0.92mm  
 body package  
**G Package**  
 Top View

TABLE 1. PIN DESCRIPTIONS

Number	Name	Type		Description
1	V <sub>DD</sub>	Power		Core supply pin.
2	FB_IN	Input	Pulldown	Feedback input to phase detector for generating clocks with "zero delay". LVCMOS / LVTTTL interface levels.
3, 9, 20, 21	GND	Power		Power supply ground.
4	FB_OUT	Output		Feedback output. Connect to FB_IN. LVCMOS / LVTTTL interface levels.
5	REF_OUT	Output		Reference clock output. LVCMOS / LVTTTL interface levels.
6, 12	V <sub>DDO</sub>	Power		Output supply pin
7, 8, 10, 11	Q3, Q2, Q1, Q0	Output		Clock outputs. 15Ω typical output impedance. LVCMOS / LVTTTL interface levels.
13	PLL_SEL	Input	Pullup	Selects between PLL and bypass mode. When HIGH, selects PLL. When LOW, selects reference clock. LVCMOS / LVTTTL interface levels.
14	V <sub>DDA</sub>	Power		Analog supply pin. See Applications Note for filtering.
15	XTAL_SEL	Input	Pullup	Selects between crystal oscillator or reference clock as the PLL reference source. Selects XTAL inputs when HIGH. Selects REF_IN when LOW. LVCMOS / LVTTTL interface levels.
16, 17	XTAL_IN, XTAL_OUT	Input		Crystal oscillator interface. XTAL_IN is the input. XTAL_OUT is the output.
18	REF_IN	Input	Pulldown	Reference clock input. LVCMOS / LVTTTL interface levels.
19, 22, 24	nc	Unused		No connect.
23	MR	Input	Pulldown	Active HIGH Master Reset. When logic HIGH, the internal dividers are reset causing the outputs go low. When logic LOW, the internal dividers and the outputs are enabled. LVCMOS / LVTTTL interface levels.
25, 26	DIV_SEL0, DIV_SEL1	Input	Pulldown	Selects divide value for clock outputs as described in Table 3. LVCMOS / LVTTTL interface levels.
27, 28	FBDIV_SEL0, FBDIV_SEL1	Input	Pulldown	Selects divide value for reference clock output and feedback output. LVCMOS / LVTTTL interface levels.

NOTE: *Pullup* and *Pulldown* refer to internal input resistors. See Table 2, Pin Characteristics, for typical values.

TABLE 2. PIN CHARACTERISTICS

Symbol	Parameter	Test Conditions	Minimum	Typical	Maximum	Units
C <sub>IN</sub>	Input Capacitance			4		pF
R <sub>PULLUP</sub>	Input Pullup Resistor				51	kΩ
R <sub>PULLDOWN</sub>	Input Pulldown Resistor				51	kΩ
C <sub>PD</sub>	Power Dissipation Capacitance (per output); NOTE 1	V <sub>DD</sub> , V <sub>DDA</sub> , V <sub>DDO</sub> = 3.465V			9	pF
		V <sub>DD</sub> , V <sub>DDA</sub> = 3.465V; V <sub>DDO</sub> = 2.625V			11	pF
R <sub>OUT</sub>	Output Impedance			15		Ω

**TABLE 3A. OUTPUT CONTROL PIN FUNCTION TABLE**

Inputs	Outputs	
MR	Q0:Q3	FB_OUT, REF_OUT
1	LOW	LOW
0	Active	Active

**TABLE 3B. OPERATING MODE FUNCTION TABLE**

Inputs	Operating Mode
PLL_SEL	
0	Bypass
1	PLL

**TABLE 3C. PLL INPUT FUNCTION TABLE**

Inputs	
XTAL_SEL	PLL Input
0	REF_IN
1	XTAL Oscillator

**TABLE 3D. CONTROL FUNCTION TABLE**

Inputs					Outputs		
					PLL_SEL=1	Frequency	
FBDIV_SEL1	FBDIV_SEL0	DIV_SEL1	DIV_SEL0	Reference Frequency Range (MHz)	Q0:Q3	Q0:Q3 (MHz)	FB_OUT (MHz)
0	0	0	0	16.67 - 41.67	x 4	66.68 - 166.68	16.67 - 41.67
0	0	0	1	16.67 - 41.67	x 3	50 - 125	16.67 - 41.67
0	0	1	0	16.67 - 41.67	x 2	33.34 - 83.34	16.67 - 41.67
0	0	1	1	16.67 - 41.67	x 1	16.67 - 41.67	16.67 - 41.67
0	1	0	0	12.5 - 31.25	x 5.33	66.63 - 166.56	12.5 - 31.25
0	1	0	1	12.5 - 31.25	x 4	50 - 125	12.5 - 31.25
0	1	1	0	12.5 - 31.25	x 2.667	33.34 - 83.34	12.5 - 31.25
0	1	1	1	12.5 - 31.25	x 1.33	16.63 - 41.56	12.5 - 31.25
1	0	0	0	10 - 25	x 6.667	66.67 - 166.68	10 - 25
1	0	0	1	10 - 25	x 5	50 - 125	10 - 25
1	0	1	0	10 - 25	x 3.33	33.30 - 83.25	10 - 25
1	0	1	1	10 - 25	x 1.66	16.60 - 41.50	10 - 25
1	1	0	0	8.33 - 20.83	x 8	66.64 - 166.64	8.33 - 20.83
1	1	0	1	8.33 - 20.83	x 6	50 - 125	8.33 - 20.83
1	1	1	0	8.33 - 20.83	x 4	33.32 - 83.32	8.33 - 20.83
1	1	1	1	8.33 - 20.83	x 2	16.66 - 41.66	8.33 - 20.83

NOTE: VCO frequency range for all configurations above is 250MHz to 500MHz.

**ABSOLUTE MAXIMUM RATINGS**

Supply Voltage, $V_{DD}$	4.6V
Inputs, $V_I$	
XTAL_IN	0V to $V_{DD}$
Other Inputs	-0.5V to $V_{DD} + 0.5V$
Outputs, $V_O$	-0.5V to $V_{DDO} + 0.5V$
Package Thermal Impedance, $\theta_{JA}$	64.5°C/W (0 mps)
Storage Temperature, $T_{STG}$	-65°C to 150°C

NOTE: Stresses beyond those listed under Absolute Maximum Ratings may cause permanent damage to the device. These ratings are stress specifications only. Functional operation of product at these conditions or any conditions beyond those listed in the *DC Characteristics* or *AC Characteristics* is not implied. Exposure to absolute maximum rating conditions for extended periods may affect product reliability.

**TABLE 4A. POWER SUPPLY DC CHARACTERISTICS,  $V_{DD} = V_{DDA} = 3.3V \pm 5\%$ ,  $V_{DDO} = 3.3V \pm 5\%$  OR  $2.5V \pm 5\%$ ,  $T_A = -40^\circ\text{C}$  TO  $85^\circ\text{C}$** 

Symbol	Parameter	Test Conditions	Minimum	Typical	Maximum	Units
$V_{DD}$	Core Supply Voltage		3.135	3.3	3.465	V
$V_{DDA}$	Analog Supply Voltage		3.135	3.3	3.465	V
$V_{DDO}$	Output Supply Voltage		3.135	3.3	3.465	V
$I_{DD}$	Power Supply Current				185	mA
$I_{DDA}$	Analog Supply Current				15	mA
$I_{DDO}$	Output Supply Current				20	mA

**TABLE 4B. LVCMOS/LVTTL DC CHARACTERISTICS,  $V_{DD} = V_{DDA} = 3.3V \pm 5\%$ ,  $V_{DDO} = 3.3V \pm 5\%$  OR  $2.5V \pm 5\%$ ,  $T_A = -40^\circ\text{C}$  TO  $85^\circ\text{C}$** 

Symbol	Parameter	Test Conditions	Minimum	Typical	Maximum	Units
$V_{IH}$	Input High Voltage	MR, DIV_SEL0, DIV_SEL1, FBDIV_SEL0, FBDIV_SEL1, XTAL_SEL, FB_IN, PLL_SEL	2		$V_{DD} + 0.3$	V
		REF_IN	2		$V_{DD} + 0.3$	V
$V_{IL}$	Input Low Voltage	MR, DIV_SEL0, DIV_SEL1, FBDIV_SEL0, FBDIV_SEL1, XTAL_SEL, FB_IN, PLL_SEL	-0.3		0.8	V
		REF_IN	-0.3		1.3	V
$I_{IH}$	Input High Current	DIV_SEL0, DIV_SEL1, FBDIV_SEL0, FBDIV_SEL1, MR, FB_IN	$V_{DD} = V_{IN} = 3.465V$		150	$\mu\text{A}$
		XTAL_SEL, PLL_SEL	$V_{DD} = V_{IN} = 3.465V$		5	$\mu\text{A}$
$I_{IL}$	Input Low Current	DIV_SEL0, DIV_SEL1, FBDIV_SEL0, FBDIV_SEL1, MR, FB_IN	$V_{DD} = 3.465V$ , $V_{IN} = 0V$	-5		$\mu\text{A}$
		XTAL_SEL, PLL_SEL	$V_{DD} = 3.465V$ , $V_{IN} = 0V$	-150		$\mu\text{A}$
$V_{OH}$	Output High Voltage; NOTE 1	$V_{DD} = V_{IN} = 3.465V$	2.6			V
		$V_{DD} = V_{IN} = 2.625V$	1.8			V
$V_{OL}$	Output Low Voltage; NOTE 1	$V_{DD} = V_{IN} = 3.465V$ or $2.625V$			0.5	V

NOTE 1: Outputs terminated with  $50\Omega$  to  $V_{DDO}/2$ . See Parameter Measurement Information section, "3.3V Output Load Test Circuit".

**TABLE 5. CRYSTAL CHARACTERISTICS**

Parameter	Test Conditions	Minimum	Typical	Maximum	Units
Mode of Oscillation		Fundamental			
Frequency		10		38	MHz
Equivalent Series Resistance (ESR)				50	$\Omega$
Shunt Capacitance			7		pF
Drive Level				1	mW

**TABLE 6. PLL INPUT REFERENCE CHARACTERISTICS,  $V_{DD} = V_{DDA} = V_{DDO} = 3.3V \pm 5\%$ ,  $T_A = -40^\circ\text{C}$  TO  $85^\circ\text{C}$** 

Symbol	Parameter	Test Conditions	Minimum	Typical	Maximum	Units
$f_{REF}$	Reference Frequency		8.33		41.67	MHz

**TABLE 7A. AC CHARACTERISTICS,  $V_{DD} = V_{DDA} = V_{DDO} = 3.3V \pm 5\%$ ,  $T_A = -40^\circ\text{C}$  TO  $85^\circ\text{C}$** 

Symbol	Parameter	Test Conditions	Minimum	Typical	Maximum	Units
$f_{MAX}$	Output Frequency				166.67	MHz
$t(\emptyset)$	Static Phase Offset; NOTE 1	FREF = 25MHz	0	160	325	ps
$t_{sk(o)}$	Output Skew; NOTE 2, 5				65	ps
$f_{jit(cc)}$	Cycle-to-Cycle Jitter; 5				120	ps
$f_{jit(per)}$	Period Jitter, RMS; NOTE 3, 5, 6				20	ps
$t_{sl(o)}$	Slew Rate		1		4	V/ns
$t_L$	PLL Lock Time				10	ms
$t_R / t_F$	Output Rise/Fall Time	20% to 80%	200		700	ps
odc	Output Duty Cycle; NOTE 4		48		52	%

NOTE: All parameters measured with feedback and output dividers set to DIV by 12 unless otherwise noted.

NOTE: Electrical parameters are guaranteed over the specified ambient operating temperature range, which is established when the device is mounted in a test socket with maintained transverse airflow greater than 500 lfm. The device will meet specifications after thermal equilibrium has been reached under these conditions.

NOTE 1: Defined as the time difference between the input reference clock and the average feedback input signal when the PLL is locked and the input reference frequency is stable. Measured at  $V_{DD}/2$ .

NOTE 2: Defined as skew between outputs at the same supply voltage and with equal load conditions. Measured at  $V_{DDO}/2$ .

NOTE 3: Jitter performance using LVCMOS inputs.

NOTE 4: Measured using REF\_IN. For XTAL input, refer to Application Note.

NOTE 5: This parameter is defined in accordance with JEDEC Standard 65.

NOTE 6: This parameter is defined as an RMS value.

**TABLE 7B. AC CHARACTERISTICS,  $V_{DD} = V_{DDA} = 3.3V \pm 5\%$ ,  $V_{DDO} = 2.5V \pm 5\%$ ,  $T_A = -40^\circ\text{C}$  TO  $85^\circ\text{C}$** 

Symbol	Parameter	Test Conditions	Minimum	Typical	Maximum	Units
$f_{MAX}$	Output Frequency				166.67	MHz
$t(\emptyset)$	Static Phase Offset; NOTE 1	FREF = 25MHz	-365	-105	160	ps
$t_{sk(o)}$	Output Skew; NOTE 2, 5				50	ps
$f_{jit(cc)}$	Cycle-to-Cycle Jitter; 5				170	ps
$f_{jit(per)}$	Period Jitter, RMS; NOTE 3, 5, 6				20	ps
$t_{sl(o)}$	Slew Rate		1		4	V/ns
$t_L$	PLL Lock Time				10	ms
$t_R / t_F$	Output Rise/Fall Time	20% to 80%	200		700	ps
odc	Output Duty Cycle; NOTE 4		48		52	%

See Table 7A for notes.

# PARAMETER MEASUREMENT INFORMATION

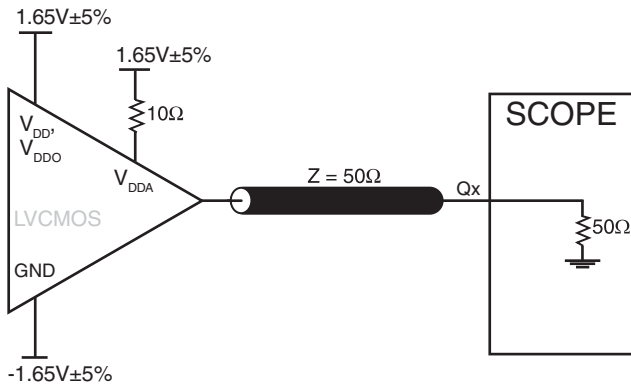

**3.3V OUTPUT LOAD AC TEST CIRCUIT**

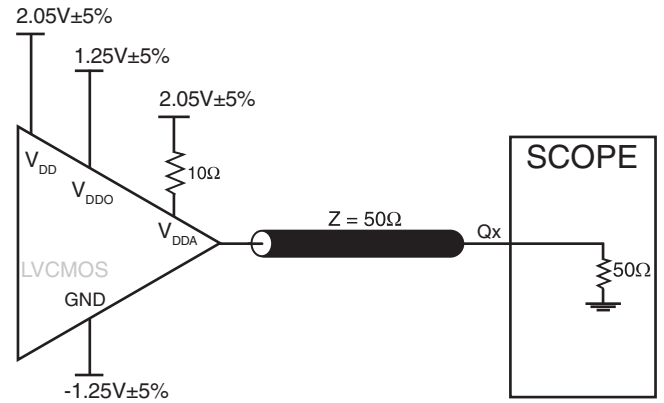

**3.3V/2.5V OUTPUT LOAD AC TEST CIRCUIT**

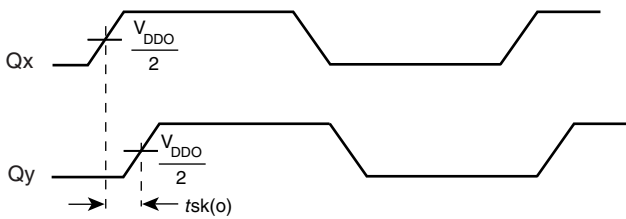

**OUTPUT SKEW**

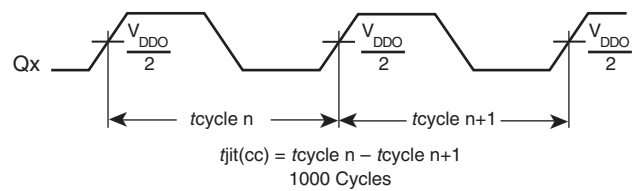

**CYCLE-TO-CYCLE JITTER**

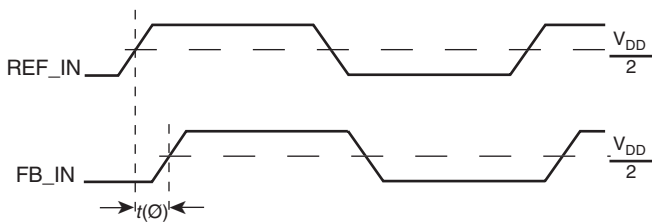

**STATIC PHASE OFFSET**

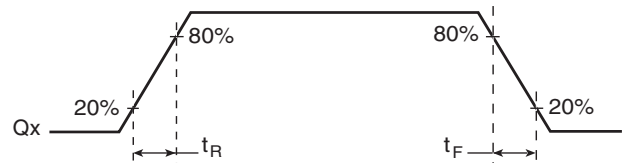

**OUTPUT RISE/FALL TIME**

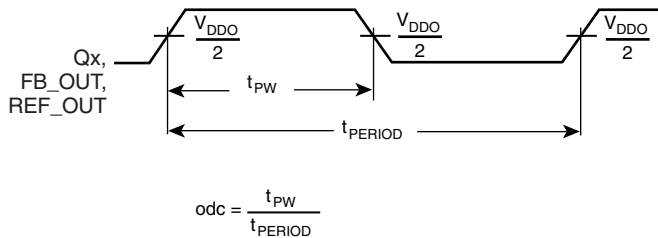

**OUTPUT PULSE WIDTH/PULSE WIDTH PERIOD**

## APPLICATION INFORMATION

### POWER SUPPLY FILTERING TECHNIQUES

As in any high speed analog circuitry, the power supply pins are vulnerable to random noise. To achieve optimum jitter performance, power supply isolation is required. The ICS87604I provides separate power supplies to isolate any high switching noise from the outputs to the internal PLL.  $V_{DD}$ ,  $V_{DDA}$ , and  $V_{DDO}$  should be individually connected to the power supply plane through vias, and  $0.01\mu\text{F}$  bypass capacitors should be used for each pin. *Figure 1* illustrates this for a generic  $V_{DD}$  pin and also shows that  $V_{DDA}$  requires that an additional  $10\Omega$  resistor along with a  $10\mu\text{F}$  bypass capacitor be connected to the  $V_{DDA}$  pin. The  $10\Omega$  resistor can also be replaced by a ferrite bead.

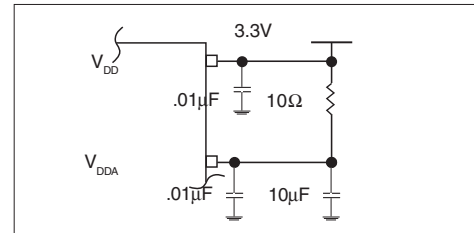

FIGURE 1. POWER SUPPLY FILTERING

### RECOMMENDATIONS FOR UNUSED INPUT AND OUTPUT PINS

#### INPUTS:

##### CRYSTAL INPUT

For applications not requiring the use of the crystal oscillator input, both XTAL\_IN and XTAL\_OUT can be left floating. Though not required, but for additional protection, a  $1\text{k}\Omega$  resistor can be tied from XTAL\_IN to ground.

##### REF\_CLK INPUT

For applications not requiring the use of the reference clock, it can be left floating. Though not required, but for additional protection, a  $1\text{k}\Omega$  resistor can be tied from the REF\_CLK to ground.

##### LVC MOS CONTROL PINS

All control pins have internal pull-ups or pull-downs; additional resistance is not required but can be added for additional protection. A  $1\text{k}\Omega$  resistor can be used.

#### OUTPUTS:

##### LVC MOS OUTPUTS

All unused LVC MOS output can be left floating. There should be no trace attached.

### CRYSTAL INPUT INTERFACE

The ICS87604I has been characterized with  $18\text{pF}$  parallel resonant crystals. The capacitor values, C1 and C2, shown in *Figure 2* below were determined using a  $25\text{MHz}$ ,  $18\text{pF}$  parallel resonant crystal and were chosen to minimize the frequency ppm error. The optimum C1 and C2 values can be slightly adjusted for optimum frequency accuracy.

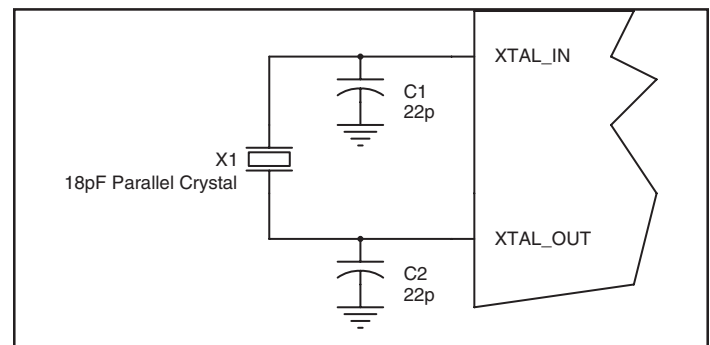
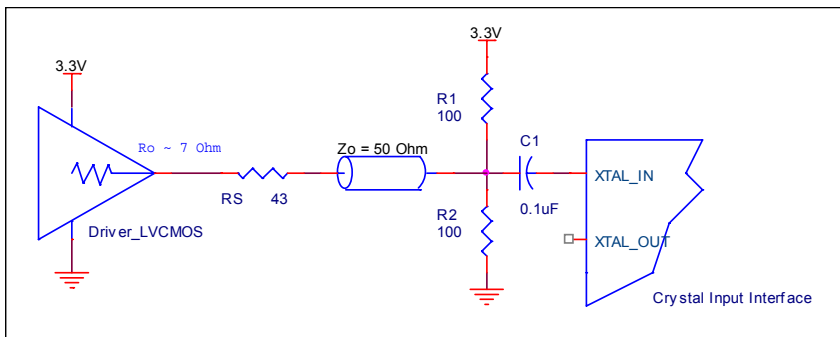

FIGURE 2. CRYSTAL INPUT INTERFACE

## OVERDRIVING THE CRYSTAL INTERFACE

The XTAL\_IN input can be overdriven by an LVCMOS driver or by one side of a differential driver through an AC coupling capacitor. The XTAL\_OUT pin can be left floating. The amplitude of the input signal should be between 500mV and 1.8V and the slew rate should not be less than .2V/nS. For 3.3V LVCMOS inputs, the amplitude must be reduced from full swing to at least half the swing in order to prevent signal interference with the power rail and to reduce internal noise. *Figure 3A* shows an example of the interface diagram for a high speed 3.3V LVCMOS driver. This configuration requires that the sum of the output impedance of the driver ( $R_o$ ) and the series resistance ( $R_s$ ) equals the transmission line impedance. In addition, matched termination at the crystal input will attenuate the signal in half. This can be done

in one of two ways. First,  $R_1$  and  $R_2$  in parallel should equal the transmission line impedance. For most 50 applications,  $R_1$  and  $R_2$  can be 100 $\Omega$ . This can also be accomplished by removing  $R_1$  and changing  $R_2$  to 50 $\Omega$ . The values of the resistors can be increased to reduce the loading for slower and weaker LVCMOS driver. *Figure 2* shows an example of the interface diagram for an LVPECL driver. This is a standard LVPECL termination with one side of the driver feeding the XTAL\_IN input. It is recommended that all components in the schematics be placed in the layout. Though some components might not be used, they can be utilized for debugging purposes. The datasheet specifications are characterized and guaranteed by using a quartz crystal as the input.



**FIGURE 3A. GENERAL DIAGRAM FOR LVCMOS DRIVER TO XTAL INPUT INTERFACE**

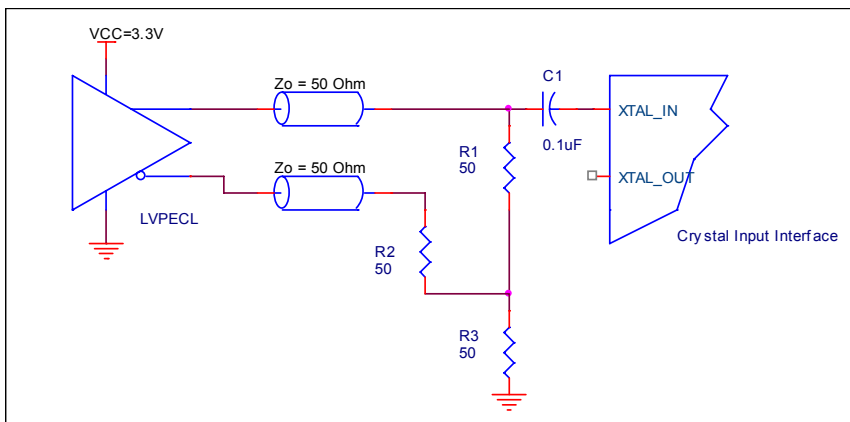

**FIGURE 3B. GENERAL DIAGRAM FOR LVPECL DRIVER TO XTAL INPUT INTERFACE**



**SCHEMATIC EXAMPLE**

Figure 4 shows a schematic example of the ICS87604I. Series termination is shown in this schematic. Additional LVCMOS termination approaches are shown in the LVCMOS Termination Application Note. In this example, an 18 pF parallel resonant 25MHz crystal is used. The C1=22pF and C2=22pF are recommended for frequency accuracy. For

different board layout, the C1 and C2 values may be slightly adjusted for optimizing frequency accuracy. The logic control inputs are either pull up or pull down depending on the application requirement. If there is space available, it is recommended to provide spare footprints as shown in the schematic for flexibility of choosing pull up or pull down.

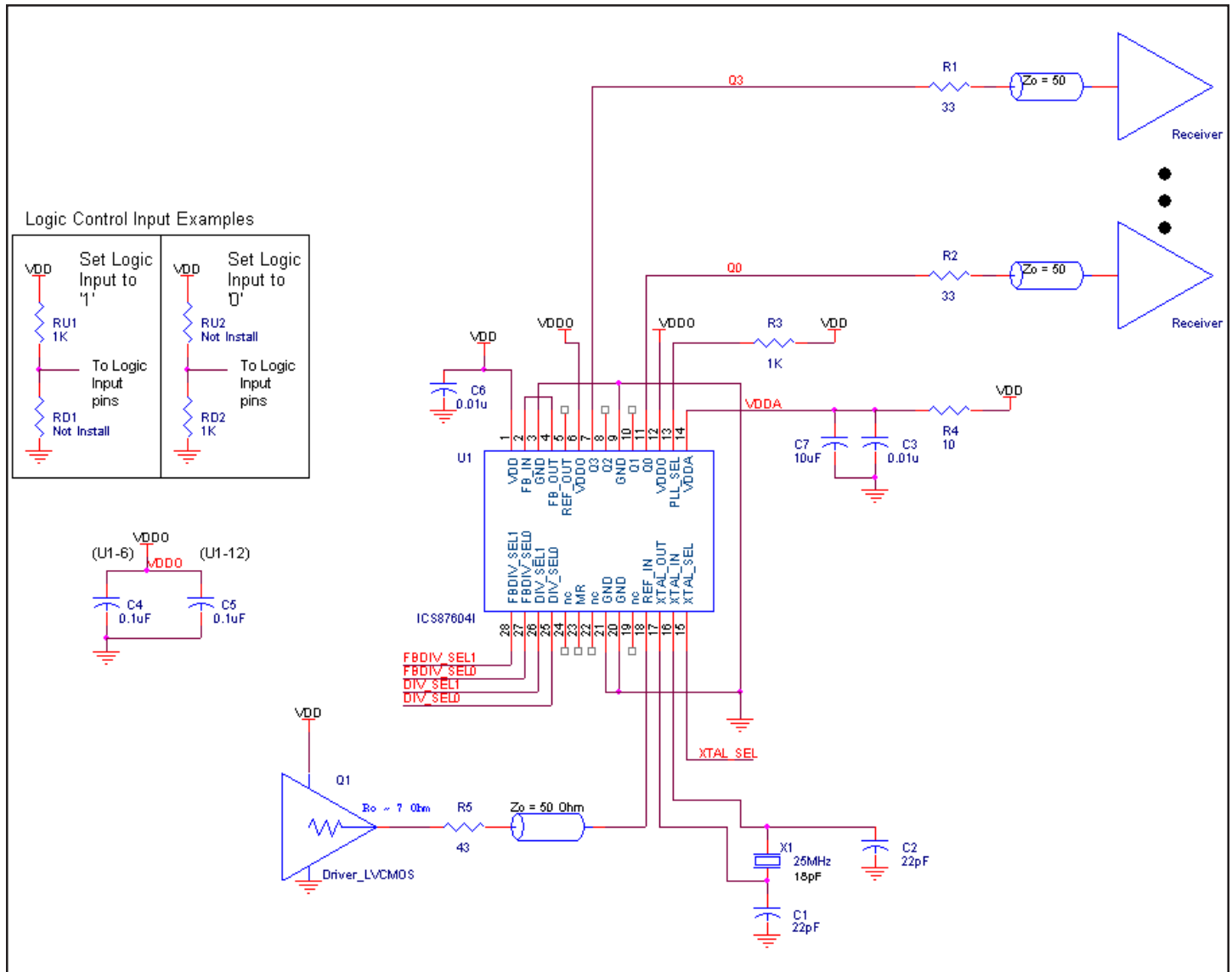

**FIGURE 4. ICS87604I SCHEMATIC EXAMPLE**

## RELIABILITY INFORMATION

TABLE 8.  $\theta_{JA}$  VS. AIR FLOW TABLE FOR 28 LEAD TSSOP

$\theta_{JA}$ by Velocity (Linear Feet per Minute)			
	0	1	2.5
Multi-Layer PCB, JEDEC Standard Test Boards	64.5°C/W	60.4°C/W	58.5°C/W

**TRANSISTOR COUNT**

The transistor count for ICS87604I is: 5495

## PACKAGE OUTLINE AND PACKAGE DIMENSIONS

PACKAGE OUTLINE - G SUFFIX FOR 28 LEAD TSSOP

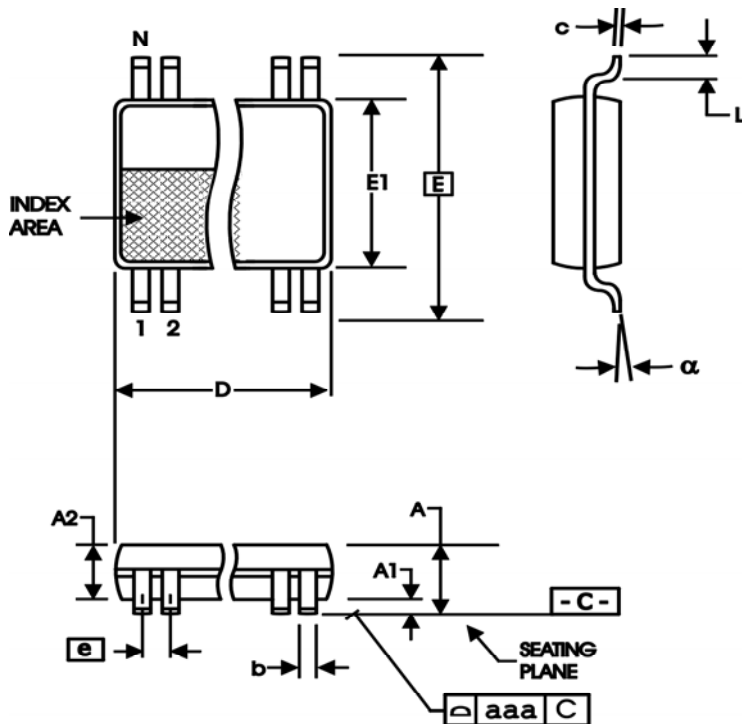

TABLE 9. PACKAGE DIMENSIONS

SYMBOL	Millimeters	
	Minimum	Maximum
N	28	
A	--	1.20
A1	0.05	0.15
A2	0.80	1.05
b	0.19	0.30
c	0.09	0.20
D	9.60	9.80
E	8.10 BASIC	
E1	6.00	6.20
e	0.65 BASIC	
L	0.45	0.75
alpha	0°	8°
aaa	--	0.10

Reference Document: JEDEC Publication 95, MO-153

**TABLE 10. ORDERING INFORMATION**

Part/Order Number	Marking	Package	Shipping Packaging	Temperature
87604AGI	ICS87604AGI	28 Lead TSSOP	tube	-40°C to 85°C
87604AGIT	ICS87604AGI	28 Lead TSSOP	1000 tape & reel	-40°C to 85°C
87604AGILF	ICS87604AGILF	28 Lead "Lead-Free" TSSOP	tube	-40°C to 85°C
87604AGILFT	ICS87604AGILF	28 Lead "Lead-Free" TSSOP	1000 tape & reel	-40°C to 85°C

NOTE: Parts that are with an "LF" suffix to the part number are the Pb-Free configuration and are RoHS compliant.

While the information presented herein has been checked for both accuracy and reliability, Integrated Device Technology, Incorporated (IDT) assumes no responsibility for either its use or for infringement of any patents or other rights of third parties, which would result from its use. No other circuits, patents, or licenses are implied. This product is intended for use in normal commercial and industrial applications. Any other applications such as those requiring high reliability or other extraordinary environmental requirements are not recommended without additional processing by IDT. IDT reserves the right to change any circuitry or specifications without notice. IDT does not authorize or warrant any IDT product for use in life support devices or critical medical instruments.

REVISION HISTORY SHEET				
Rev	Table	Page	Description of Change	Date
A	T7A & T7B	5	AC Characteristics Tables - corrected note sequence.	3/18/05
A	10	10	Ordering Information Table - added marking.	4/12/05
B	T5	1	Pin Assignment and General Description - corrected package dimension.	3/8/06
		5	Crystal Characteristics - added Drive Level.	
		6	Updated Output Load AC Test Circuit Diagrams.	
		8	Application Information - added <i>LVTMOS to XTAL Interface</i> and <i>Recommendations for Unused Input and Output Pins</i> sections.	
	T9	10	Package Dimensions - corrected "E" and "E1" dimensions.	
B	T9	1	Pin Assignment and General Description - corrected package dimension.	8/18/06
		10	Package Dimensions - corrected "E" and "E1" dimensions.	
B		4	Absolute Maximum Ratings - updated Package Thermal Impedance.	1/11/08
		9	Added Schematic Layout.	
		10	Reliability Information - updated Package Thermal Impedance.	
B	T7A	1	Pin Assignment, corrected 173-MIL to 240-MIL.	4/1/10
	T10	5	AC Characteristics Table, added Thermal Note.	
		8	Updated the <i>Overdriving the Crystal Interface</i> section.	
		11	Ordering Information Table - deleted "ICS" prefix from Part/Order Number column. Added new Header/Footer in datasheet.	



[www.IDT.com](http://www.IDT.com)

6024 Silver Creek Valley Road  
San Jose, CA 95138

**Sales**

800-345-7015 (inside USA)  
+408-284-8200 (outside  
USA)

Fax: 408-284-2775

[www.IDT.com/go/contactIDT](http://www.IDT.com/go/contactIDT)

**Technical Support**

[netcom@idt.com](mailto:netcom@idt.com)  
+480-763-2056

DISCLAIMER Integrated Device Technology, Inc. (IDT) and its subsidiaries reserve the right to modify the products and/or specifications described herein at any time and at IDT's sole discretion. All information in this document, including descriptions of product features and performance, is subject to change without notice. Performance specifications and the operating parameters of the described products are determined in the independent state and are not guaranteed to perform the same way when installed in customer products. The information contained herein is provided without representation or warranty of any kind, whether express or implied, including, but not limited to, the suitability of IDT's products for any particular purpose, an implied warranty of merchantability, or non-infringement of the intellectual property rights of others. This document is presented only as a guide and does not convey any license under intellectual property rights of IDT or any third parties.

IDT's products are not intended for use in life support systems or similar devices where the failure or malfunction of an IDT product can be reasonably expected to significantly affect the health or safety of users. Anyone using an IDT product in such a manner does so at their own risk, absent an express, written agreement by IDT.

Integrated Device Technology, IDT and the IDT logo are registered trademarks of IDT. Other trademarks and service marks used herein, including protected names, logos and designs, are the property of IDT or their respective third party owners.

Copyright 2010. All rights reserved.