

### PRODUCT DESCRIPTION

The SP 200 features a 200mV d.c. measurement range with auto-zero and auto-polarity. Decimal points are user selectable. The SP 200 features a negative rail generator which enables the meter to measure a signal referenced to its own power supply GND. LED backlighting ensures excellent readability under low light conditions. The module is easily fitted into the panel, using the fixing clip provided. The module's low cost means it will suit high and low volume applications. The design of the panel meter's housing ensures splash proofing using the supplied seal.

### FEATURES

- 9.75mm (0.38") Digit Height
- 200mV d.c. Full Scale Reading
- 350µA @ +5V d.c. Power Supply
- Auto-zero and Auto-polarity
- Programmable Decimal Points
- LED Backlighting
- Low Battery Warning
- Splash Proof



### TYPICAL APPLICATIONS

- Precision Instrumentation Systems
- Power Supply Monitoring
- Test Boxes
- Panel-Mount Indication
- Low Power Voltage Measurement

### ORDERING INFORMATION

Standard Meter	Stock Number <b>SP 200</b>
----------------	-------------------------------

### ELECTRICAL SPECIFICATIONS

Specification	Min.	Typ.	Max.	Unit
Accuracy (overall error) *		0.1		% (±1 count)
Linearity			±1	count
Sample rate		2.5		samples/sec
Operating temperature range	0		50	°C
Temperature stability		100		ppm/°C
Supply voltage	3.5	5	5.25	V
Supply current		350		µA
Backlight current @ 5V d.c.		40	80	mA
Input leakage current (Vin = 0V)		1	10	pA

\* To ensure maximum accuracy, re-calibrate periodically.

### SAFETY

To comply with the Low Voltage Directive (LVD 93/68/EEC), input voltages to the module's pins must not exceed 60Vdc. The user must ensure that the incorporation of the panel meter into the user's equipment conforms to the relevant sections of BS EN 61010 (Safety Requirements for Electrical Equipment for Measuring, Control and Laboratory Use).

### DIMENSIONS

All dimensions in mm (inches)

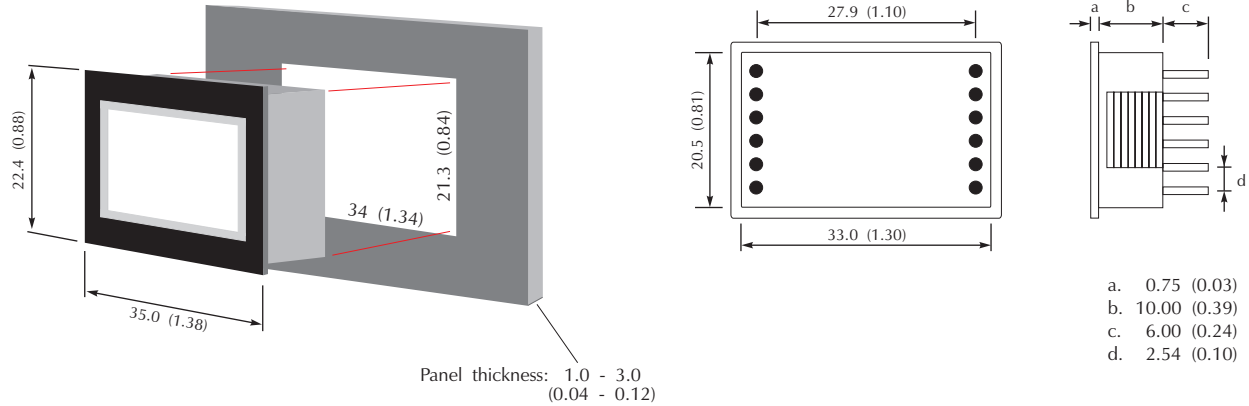

### PANEL FITTING

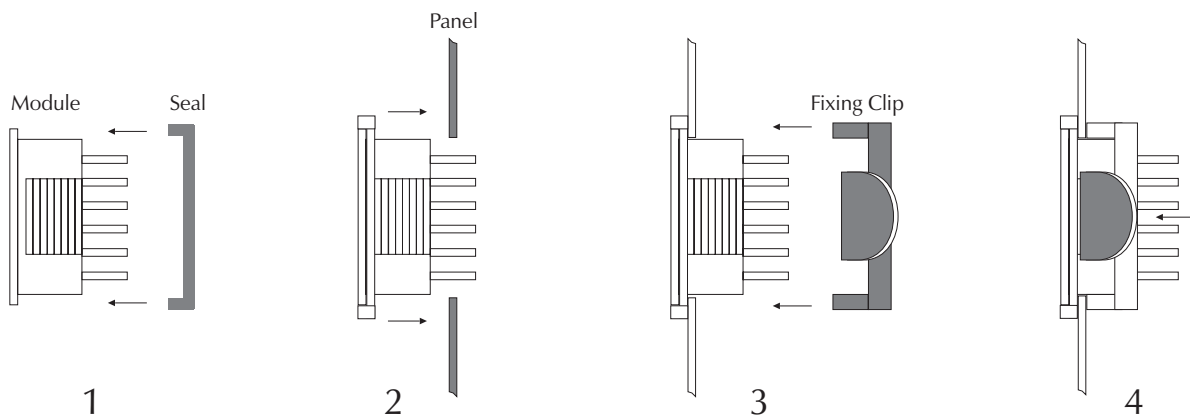

### FUNCTIONAL BLOCK DIAGRAM

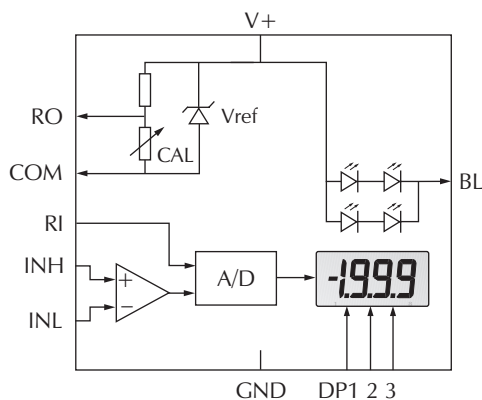

### PIN CONFIGURATION (rear view)

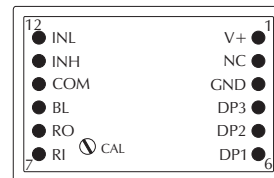

## CIRCUIT DIAGRAM

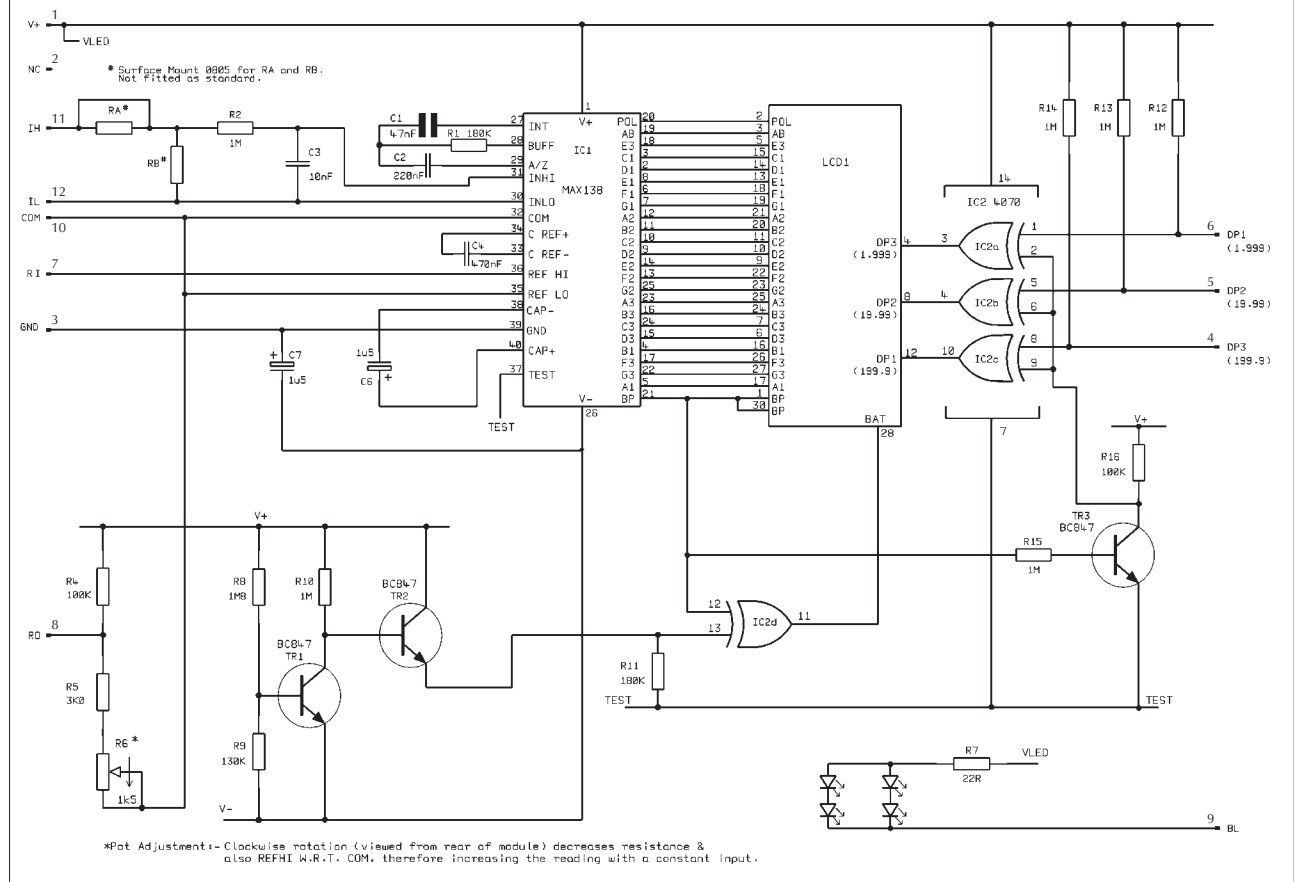

## PIN FUNCTIONS

1. V+ Positive power supply to the meter and LED backlighting.
2. NC Not connected.
3. GND 0V power supply connection to the meter.
4. DP3 Connect to GND to display DP3 (199.9).
5. DP2 Connect to GND to display DP2 (19.99).
6. DP1 Connect to GND to display DP1 (1.999).
7. RI Reference voltage input for the meter's A/D converter.
8. RO Precision reference voltage output. Connect to RI for normal operation.
9. BL Connect to GND to switch on the LED backlighting.
10. COM Ground for analogue section of A/D converter.  
It is actively held at 2.8V below V+ and must not be allowed to sink excessive current (>100µA) by, for instance, connecting to a higher voltage.
11. IH Positive measuring input.  
IH must be no closer than 1.5V to either the positive or negative supply.
12. IL Negative measuring input.  
IL must be no closer than 1.5V to the positive supply.

### Note:

A negative supply is generated internally and mirrors the positive supply. For example: if V+ is +5V, then the internally generated V- is -5V. When measuring with the input referenced to the same supply rail as that of the panel meter, then the limitations on the input range are (V- + 1.5V) to (V+ - 1.5V).

### SCALING

Two resistors Ra and Rb may be used to alter the full scale reading (FSR) of the meter - see table. The meter will have to be recalibrated by adjusting the calibration potentiometer on the rear of the module.

	FSR	Ra	Rb
Voltage Vin	2V	910k	100k
	20V	1M	10k
	200V	1M	1k
	2000V*	1M	100R
Current Iin	200µA	0R	1k
	2mA	0R	100R
	20mA	0R	10R
	200mA	0R	1R

\*Ensure that Ra is rated for high voltage use.

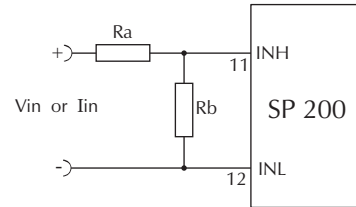

### APPLICATIONS

Do not connect more than one meter to the same power supply if the meters cannot use the same signal ground. Taking any input beyond the power supply rails will damage the meter.

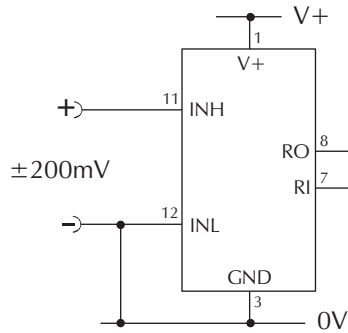

Measuring a single ended input voltage referenced to supply, i.e. the input voltage and the meter's power supply share the same 0V rail.

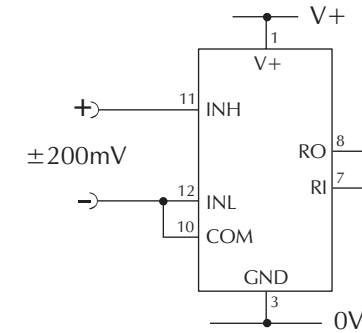

Measuring an input voltage referenced to a floating supply, i.e. the input voltage and the meter's power supply are isolated from each other.

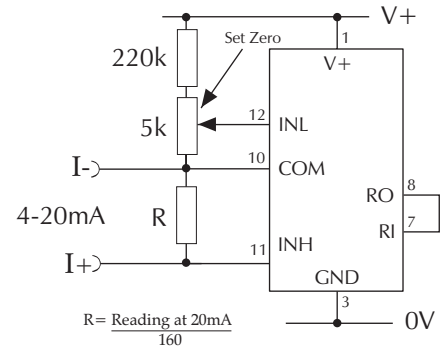

Measuring a 4-20mA loop current. The meter's power supply must be isolated from the 4-20mA current loop.

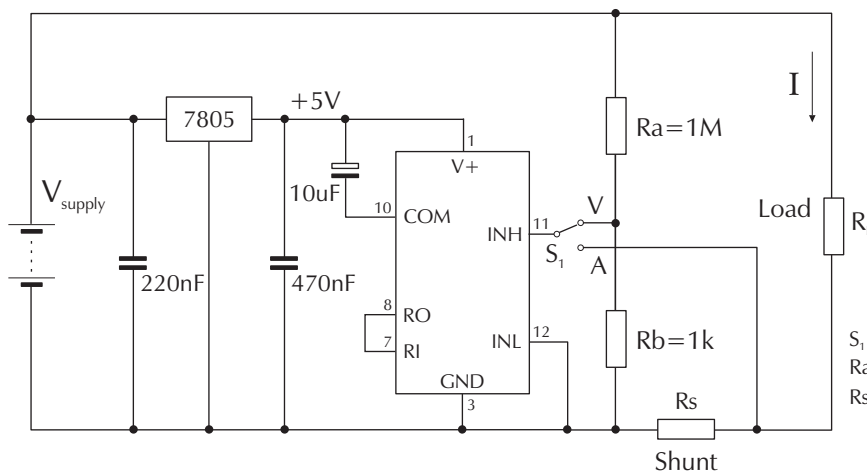

Measuring supply voltage and current to a load.  
Display DP1, DP2 or DP3 by connecting to GND, as required.

S<sub>1</sub> selects between voltage and current display.  
Ra and Rb shown scaled for 200V<sub>FSR</sub>.  
 $R_s = \frac{200\text{mV}}{I}$  (e.g. 0.1Ω for 2A range)