

VPI - PANEL MOUNTING & WIRING

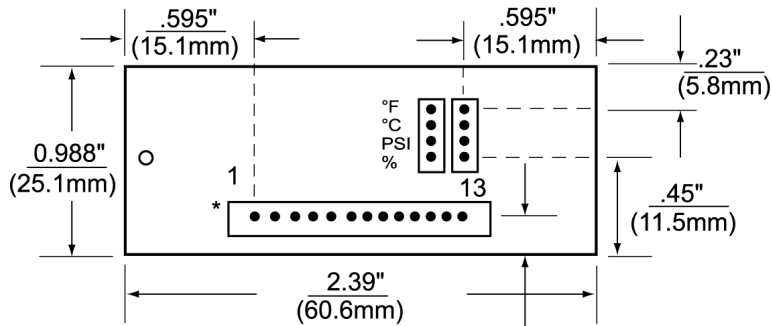

*NOTE:
(13) .025" square pins on .1" centers

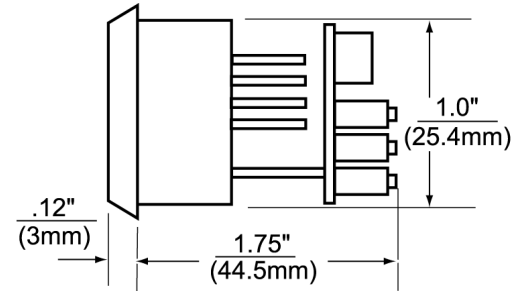
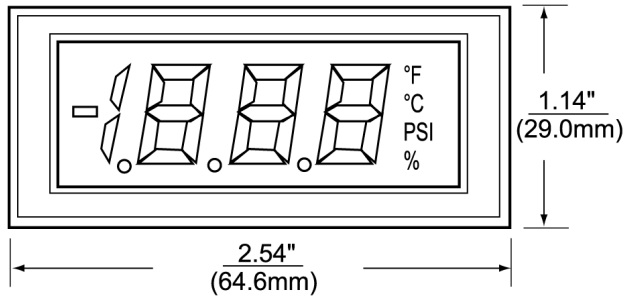
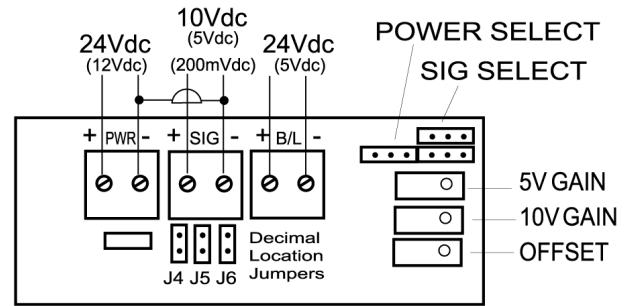
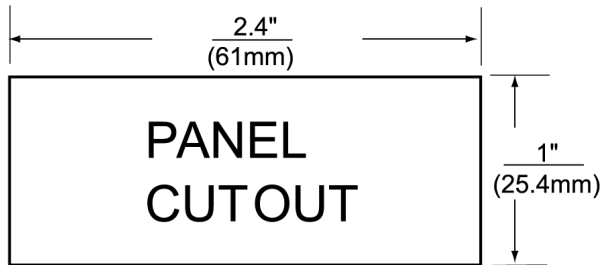

(upper)
WIRING

Decimal Point Selection

1. Locate jumpers J4 through J6 in the middle of the circuit board unit.
2. Jumper the appropriate decimal location as follows:
 - J4 - 000.0
 - J5 - 00.00
 - J6 - 0.000
 - None - 0000