

Flat Pack Pins Wiring

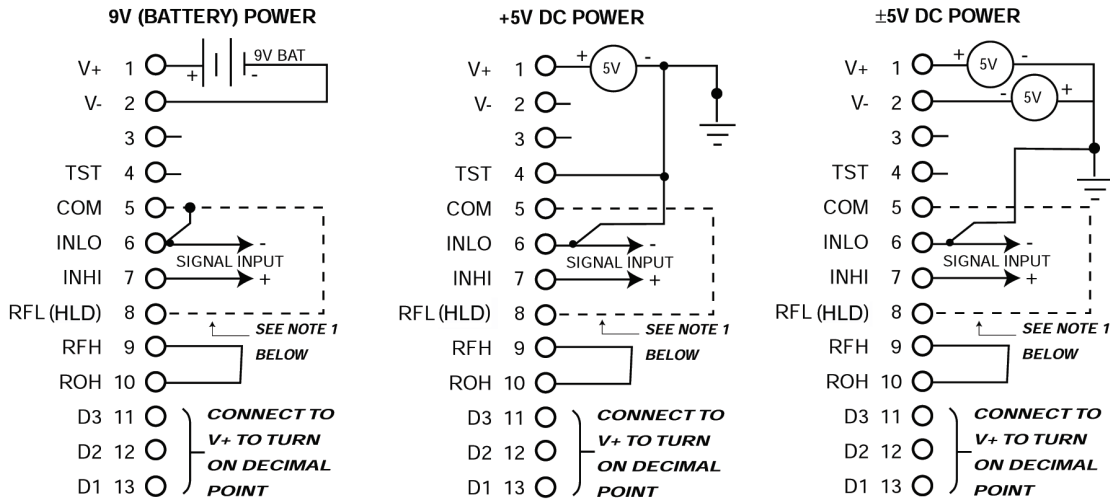

NOTES:

1. On DPMs with the hold option, DO NOT connect "COM" & "RFL".
2. Isolate the input from supply with 9V connection shown.
3. The common mode range of the input on ±5V & +5V powered DPMs is ±2V max
4. DO NOT solder pins.
5. The 5V backlight power supply is separate from that of the DPM.
Connect the supply returns together to reduce noise.
6. CAUTION: The DPM part number must match the correct supply voltage.

IS-006

Rev. 3H06

