



INTERNATIONAL HEADQUARTERS
20 Willow Springs Circle, York, Pa. 17402, (717) 767-6511 FAX: (717) 764-0839
Web site- <http://www.redlion-controls.com> E-mail- sales@redlion-controls.com

EUROPEAN HEADQUARTERS
892 Plymouth Road, Slough, Berkshire SL1 4LP
ENGLAND +44 1753 696888 FAX: +44 1753 696339

SUB-CUB-R - COMPLETE 6-DIGIT COMPONENT RATE INDICATOR/FREQUENCY METER

- LSI COUNTER CHIP WITH TIME BASE CHIP AND 0.35" (9 mm) HIGH LCD DISPLAY
- SNAP MOUNTS DIRECTLY ONTO P.C. BOARD
- SOLDERLESS, ELASTOMERIC INTERCONNECTS
- ULTRA LOW POWER, 25 μ A AT 3 V (Typical)
- SELECTABLE TIME BASE FROM 3.9 MSEC TO 15.9 SEC
- FREQUENCY DOUBLING CAPABILITY
- SELECTABLE DECIMAL POINT POSITIONS
- MASTER RESET TO SYNCHRONIZE TIME BASE WITH EXTERNAL FUNCTIONS



DESCRIPTION

As a completely self-contained tachometer/display module, the SUB-CUB-R can be treated as a component just like any other I.C. The module contains a custom monolithic counter/driver chip, a custom time base chip, and a 6-digit Liquid Crystal Display. The time base of the SUB-CUB-R is determined by the logic level of the Time Base Inputs and is selectable from approx 0.0039 second up to approximately 15.9 seconds in .0039 second increments. The SUB-CUB-R also allows for the selection of a decimal point position. The Master Reset input allows the user to synchronize the SUB-CUB-R time base with external operations.

This module is ideal for internal "on board" applications where a readout of

rate or frequency is needed within a circuit enclosure for maintenance, diagnostic, tune-up, or other data readout requirements. The SUB-CUB-R can also be mounted with a convenient bezel kit to provide a very flexible and economical panel instrument.

The SUB-CUB-R snap-mounts directly on to any 1/16" P.C. Board that has been etched to provide a mating interconnect pattern with two mounting holes and a polarizing "key" hole. Interconnections to the P.C. Board as well as internal connections are made with elastomeric connectors that provide corrosion-proof, gas-tight interface contacts for high reliability.

MOUNTING & DIMENSIONS

Snap in mounting on the P.C. Board is facilitated by two, split, lock-ramp pins which engage mounting holes drilled in the P.C. Board. The silicone rubber elastomeric connectors compress to accommodate P.C. Board thickness variation of ± 0.005 ".

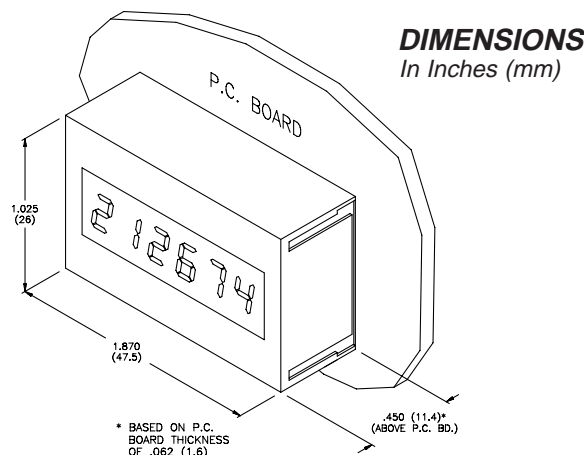
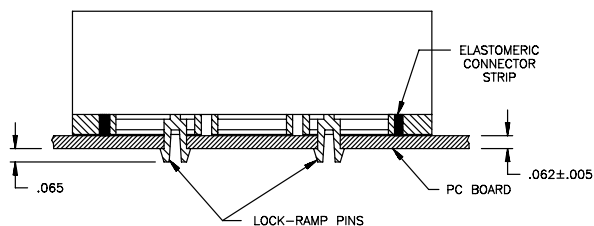

P.C. BOARD LAYOUT

P.C. Board pads may be gold or tin-lead plated. Pad surface must be flat without excessive tin-lead build-up. (Layout view is from SUB-CUB-R mounting side of board.) Pad area must be clean and free of contaminants so that proper electrical contact can be made.

Note: All hole size tolerances ± 0.003 " (0.08 mm)
All other tolerances ± 0.005 " (0.13 mm)

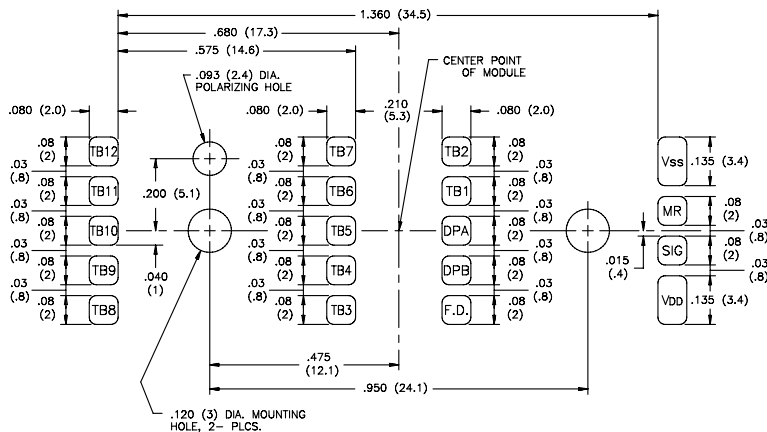

DEVICE CONNECTIONS

TB12 - CMOS *Pulsed Pull-up Latched input. When input is connected to V_{SS} , 8 seconds is added to the total time base period. When input is connected to V_{DD} or left open, no time is added to the total time base period.

TB11 - CMOS *Pulsed Pull-up Latched input. Adds 4 seconds to the total time base period when input is connected to V_{SS} .

TB10 - CMOS *Pulsed Pull-up Latched input. Adds 2 seconds to the total time base period when input is connected to V_{SS} .

TB9 - CMOS *Pulsed Pull-up Latched input. Adds 1 second to the total time base period when input is connected to V_{SS} .

TB8 - CMOS *Pulsed Pull-up Latched input. Adds 1/2 second to the total time base period when input is connected to V_{SS} .

TB7 - CMOS *Pulsed Pull-up Latched input. Adds 1/4 second to the total time base period when input is connected to V_{SS} .

TB6 - CMOS *Pulsed Pull-up Latched input. Adds 1/8 second to the total time base period when input is connected to V_{SS} .

TB5 - CMOS *Pulsed Pull-up Latched input. Adds 1/16 second to the total time base period when input is connected to V_{SS} .

TB4 - CMOS *Pulsed Pull-up Latched input. Adds 1/32 second to the total time base period when input is connected to V_{SS} .

TB3 - CMOS *Pulsed Pull-up Latched input. Adds 1/64 second to the total time base period when input is connected to V_{SS} .

TB2 - CMOS *Pulsed Pull-up Latched input. Adds 1/128 second to the total time base period when input is connected to V_{SS} .

TB1 - CMOS *Pulsed Pull-up Latched input. Adds 1/256 second to the total time base period when input is connected to V_{SS} .

DPA - CMOS *Pulsed Pull-up Latched input. When used along with DPB, selects the position of the decimal point.

DPB - CMOS *Pulsed Pull-up Latched input. When used along with DPA, selects the position of the decimal point.

FD - CMOS *Pulsed Pull-up Latched input. When input is connected to V_{SS} , Frequency Doubling is disabled. When input is connected to V_{DD} or left open, Frequency Doubling is enabled.

MR - CMOS Internally Pulled-up input. When input is connected to V_{SS} , Master Reset will terminate the present time base period. When MR is allowed to go high, the next time base period will begin. In normal use, MR is connected to V_{DD} or left open. Note that this is not a Pulsed Pull-up Latched input.

* See section on "Pulsed Pull-Up Latched Inputs" for more information.

Note: For maximum noise immunity, connect all TB inputs to either V_{DD} or V_{SS} , whichever is appropriate. Inputs left open may change states in some noisy environments.

BLOCK DIAGRAM

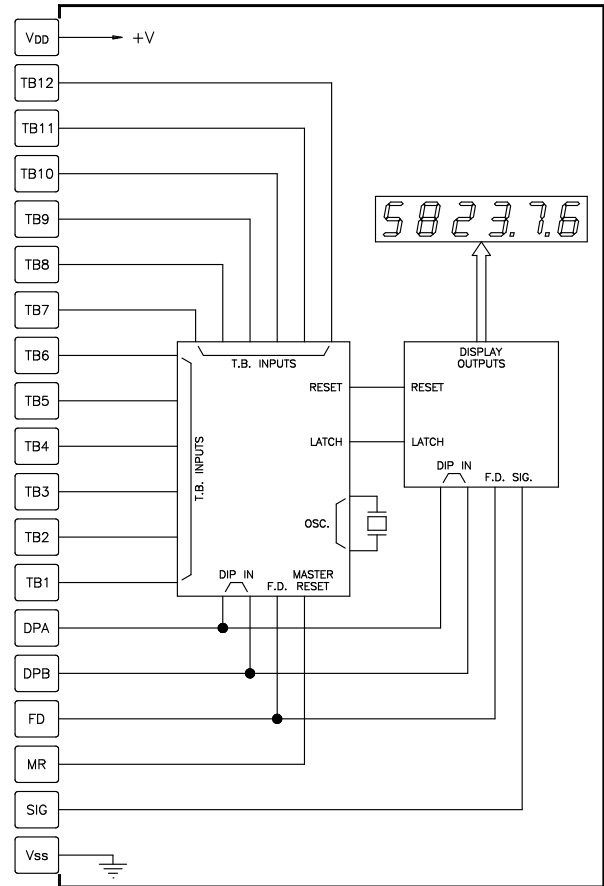

SIG. - CMOS Schmidt trigger input. Counter chip increments on the falling edge of the Signal input when F.D. is connected to V_{SS} (disabled). Counter chip increments on both rising and falling edges of the Signal input when F.D. is connected to V_{DD} or left open (enabled).

V_{DD} - +2.5 to 6.0 VDC Supply

V_{SS} - Common for D.C. Supply and Inputs.

CAUTION

This device contains CMOS circuitry which requires special anti-static handling to the same degree required by standard CMOS integrated circuits. Units should be stored in the conductive packaging used to ship the devices. Containers should be opened and units handled only on a conductive table top by personnel wearing wrist-strap grounding equipment. These devices have the same protection circuits as standard CMOS devices to prevent damage to inputs due to nominal over-voltage.

MAXIMUM RATINGS (VOLTAGE REF. TO V_{SS})

RATING	SYMBOL	VALUE	UNIT
DC Supply Voltage	V_{DD}	-0.5 to +6.5	VDC
Input Voltage, All Inputs	V_I	-0.5 to ($V_{DD} + 0.5$)	VDC
Operating Temperature*	T_A	-35 to +85	°C
Storage Temperature	T_{STG}	-35 to +85	°C

* Extended high and low temperature ranges available, consult factory.

ELECTRICAL CHARACTERISTICS $V_{DD} = 5 \text{ V} \pm 10\%$ UNLESS OTHERWISE SPECIFIED

SYMBOL	PARAMETER	MIN.	TYP.	MAX.	UNIT	TEST CONDITION
V_{DD}	Supply Voltage	2.5		6.0	VDC	
I_{DD}	Supply Current			55	μA	10 KHz signal, 1 second time base. All other inputs high.
I_{DDQ}	Supply Current			45	μA	1 second time base. All other inputs high.
V_{SIH}	Input High Voltage	3.9	3.0		VDC	Signal input only.
V_{SIL}	Input Low Voltage		0.9	0.5	VDC	Signal input only.
V_{IH}	Input High Voltage		2.2		VDC	All other inputs.
V_{IL}	Input Low Voltage		2.1		VDC	All other inputs.
I_{SIL}	Input Leakage		0.01	0.1	μA	$V_{DD} \geq V_{IN} \geq V_{SS}$ Signal input only.
I_{IH}	Input High Current (source)	50		200	μA	All other inputs.
fc	Signal Frequency			500	KHz	
R_{PU}	Pull Up Resistance		50		K Ω	All pull-up inputs.
T_{ACC}	Time Base Accuracy	0.05			%	All time ranges.

TIME BASE SELECTION

The SUB-CUB-R has a time base selection range of approx. 3.9 msec to 15.9 seconds in 3.906 msec (1/256 second) increments. The minimum time base setting is obtained by pulling only the TB1 input low while the maximum time base is obtained by pulling all TB inputs low. Therefore, a specific time base is achieved by adding the appropriate individual time base increments. The time base increment total is computed according to the following formula:

$$\frac{\text{TIME BASE INCREMENT}}{\text{TOTAL (TBIT)}} = \frac{\text{DR} \times \text{DDP} \times 15,360}{\text{RPM} \times \text{PPR}}$$

WHERE:

DR = Desired Reading
 DDP = Display Decimal Point
 RPM = Revolutions Per Minute
 PPR = Pulses Per Revolution

DDP:

0 = 1 The Display Decimal Point (DDP) value is
 0.0 = 10 determined by the desired decimal point
 0.00 = 100 placement in the readout.

TIME BASE INPUT	TIME BASE INCREMENT
TB1	1
TB2	2
TB3	4
TB4	8
TB5	16
TB6	32

TIME BASE INPUT	TIME BASE INCREMENT
TB7	64
TB8	128
TB9	256
TB10	512
TB11	1024
TB12	2048

EXAMPLE: Find the appropriate Time Base input settings for a desired display reading with a fixed shaft speed.

DESIRED READING (DR) = 250.0
 REVOLUTIONS PER MINUTE (RPM) = 1250
 PULSES PER REVOLUTION (PPR) = 50

$$\text{TBIT} = \frac{250.0 \times 10 \times 15,360}{1250 \times 50} = \frac{38,400,000}{62,500} = 614.4$$

TBIT = 614 (round off to the nearest whole number)

TIME BASE INPUT	REMAINDER NEEDED
TB10 (512)	614 - 512 = 102
TB7 (64)	102 - 64 = 38
TB6 (32)	38 - 32 = 6
TB3 (4)	6 - 4 = 2
TB2 (2)	2 - 2 = 0

As shown above, Time base inputs TB10, TB7, TB6, TB3, TB2 are pulled low to generate the desired time base. The actual time base in seconds is calculated by dividing the TBIT Total by 256.

$$614/256 = 2.398 \text{ sec.}$$

FREQUENCY DOUBLING

FD is the Frequency Doubling input. When it is in the high state or left open, twice the number of input pulses are registered on the readout. This doubling of the signal input rate allows the Time Base Increment Total (TBIT) to be halved, thus allowing for a faster update time for a given display value. If this input is in the low state, Frequency Doubling is disabled.

DECIMAL POINT SELECTION

The selection of the Decimal Point is accomplished by the DPA and DPB inputs. The table below shows the logic states which should be used to obtain the desired decimal point location. The SUB-CUB-R has leading zero blanking. Note that a change in decimal point position will only occur at the end of the present time base period.

DPB	DPA	D.P. LOCATION
Low	Low	Factory Test Mode Only
Low	High/Open	0
High/Open	Low	0.0
High/Open	High/Open	0.00

PULSED PULL-UP LATCHED INPUTS

The Time base inputs, the Decimal Point inputs, and the Frequency Doubling inputs are designed to be actuated by wired or switched connection to Common or by switching an open collector of a transistor to Common. A pull-up resistance is provided for all of these inputs. To keep current consumption to a minimum, this input circuit has been designed to latch the present state of the inputs, allowing the pull-up resistance to be switched on and off, thus reducing current consumption. The following is a description of the sequence of events for these inputs (*Refer to the drawing below*):

At the end of a previous time base, a 30.5 µsec pulse is generated within the time base chip which will cause Q1 to switch ON the input's pull-up resistance. During this time, if the input is being held low, the input will provide a sourcing current pulse thru Q1. The level of the input (*either low or high*) is sensed by the input's Latching Circuit. When the pulse is terminated, the Latching Circuit will hold the input at its present state.

If an input, which is presently in the high state, is pulled low, the Latching Circuit will respond immediately and latch the input in the low state. If an input is presently held in the low state, and is allowed to float, the Latching Circuit cannot respond until the end of the time base; at which time, the Pulsed Pull-up resistance will pull the input high. The Latching Circuit will then latch the high state. A Master Reset (MR) will terminate the present time base and allow new TB inputs to be latched.

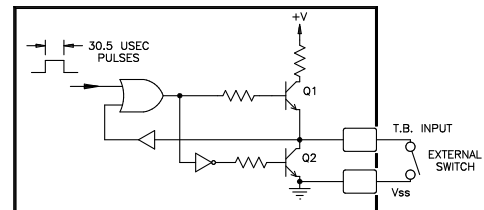

TYPICAL APPLICATIONS

FLOW RATE

The SUB-CUB-R, along with some signal conditioning circuitry, can be used as a flow indicator to measure the flow of liquid. A flow gage with a magnetic type output is used to sense the rotation of the impeller, and its output is fed through an amplifier circuit to the SIG input. Since the output of the flow gage is an A.C. voltage, diodes D1 and D2 are used to clamp the output signal swing to within ± 0.7 volts of the supply voltage. Diode D3 is used to prevent the voltage from rising above 6.0 VDC to prevent damaging the SUB-CUB-R. The time base of the SUB-CUB-R is set to 0.5 sec (*TB8 is connected to V_{SS}*). Frequency doubling is enabled (*FD is connected to V_{DD}*). This will allow the meter to produce the appearance of a 1 second time base which updates twice a second. The time base of the SUB-CUB-R can be varied to produce different time bases required for different fluids. A second position decimal point is selected (*DPA and DPB are connected to V_{DD}*).

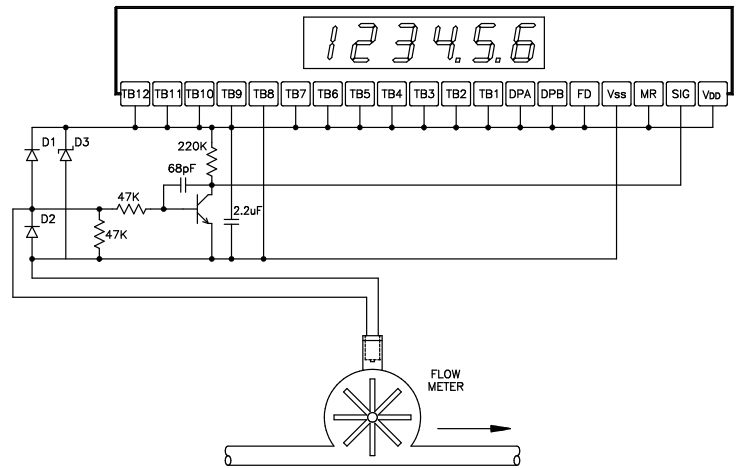

DISPLAY FOR SPEED OF SMALL PRINTING PRESS

The SUB-CUB-R can be used to indicate the speed of the web of a small printing press in both tenths of feet per minute and in tenths of meters per minute. When the press is running at its maximum rate, the web is turning at a rate of 1800 RPM, and the press is running at 250 feet per minute (*76.2 meters per minute*). The drive control produces a signal of 60 pulses per revolution of web. To align the registration marks in the set-up mode, the press speed is only 25 feet per minute.

The controller for the press provides a logic pulse which corresponds to its speed. This logic pulse is fed through a buffer to the Signal input of the SUB-CUB-R. The time base is determined by the position of the Selector switch. In the first position, the SUB-CUB-R display will read out in tenths of feet per minute. In the second position, the display will be in tenths of meters. Note that Frequency Doubling is used to reduce the update time of the SUB-CUB-R. The first decimal point is turned on by the logic levels of DPA and DPB.

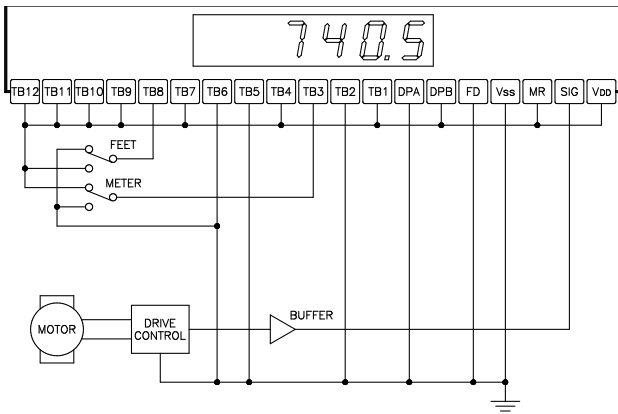

To determine the proper TB input settings for both feet per minute and for meters per minute, use the following formula.

$$\text{TIME BASE INCREMENT TOTAL (TBIT)} = \frac{\text{DR} \times \text{DDP} \times 15,360}{\text{RPM} \times \text{PPR}}$$

For Feet Per Minute:

$$\begin{aligned} \text{TBIT} &= \frac{250.0 \times 10 \times 15,360}{1800 \times 60} \\ &= 355.6 \\ &= 177.8 (\div 2 \text{ when using F.D.}) \\ &= 178 \text{ (rounded off to the nearest whole number)} \end{aligned}$$

$$\text{TBIT} = 178$$

TB8	- 128	Needed = 50
TB6	- 32	Needed = 18
TB5	- 16	Needed = 2
TB2	- 2	Needed = 0

For Meters Per Minute:

$$\begin{aligned} \text{TBIT} &= \frac{76.20 \times 10 \times 15,360}{1800 \times 60} \\ &= 108.4 \\ &= 54.2 (\div 2 \text{ when using F.D.}) \\ &= 54 \text{ (rounded off to the nearest whole number)} \end{aligned}$$

$$\text{TBIT} = 178$$

TB6	- 32	Needed = 22
TB5	- 16	Needed = 6
TB3	- 4	Needed = 2
TB2	- 2	Needed = 0

SUB-CUB-R PROTOTYPING BOARD (P/N DMOSCB04)

This board is a handy way of doing experimental and prototyping work with the SUB-CUB-R. It easily plugs onto standard 0.1" spacing bread boards. This in turn, greatly simplifies bread board work.

SUB-CUB-R
PROTOTYPING
BOARD
P/N DMOSCB04

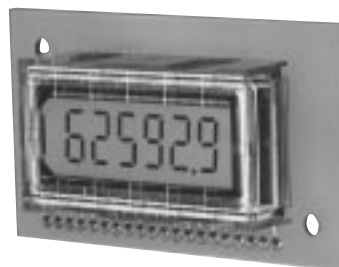

PANEL BEZEL KIT FOR THE SUB-CUB-R (P/N HWK60000)

This kit provides a convenient way to adapt the SUB-CUB-R for panel mounting. The kit includes the black plastic bezel, the panel and internal window gaskets, P.C. Board, 12" ribbon cable and mounting screws.



ASSEMBLY

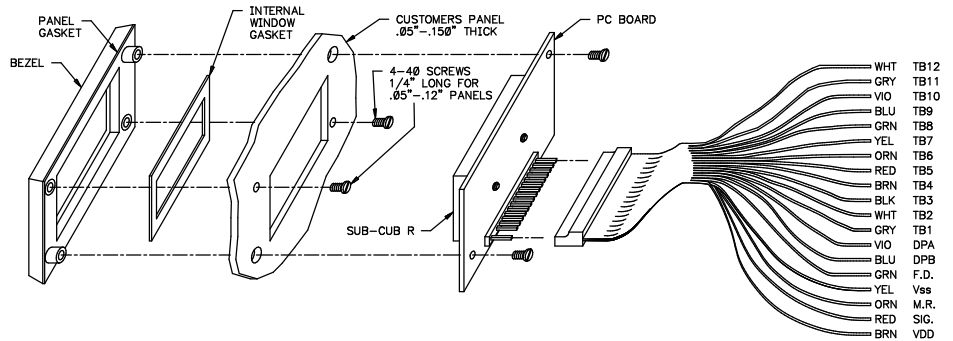

DIMENSIONS & PANEL CUT-OUT "In inches (mm)

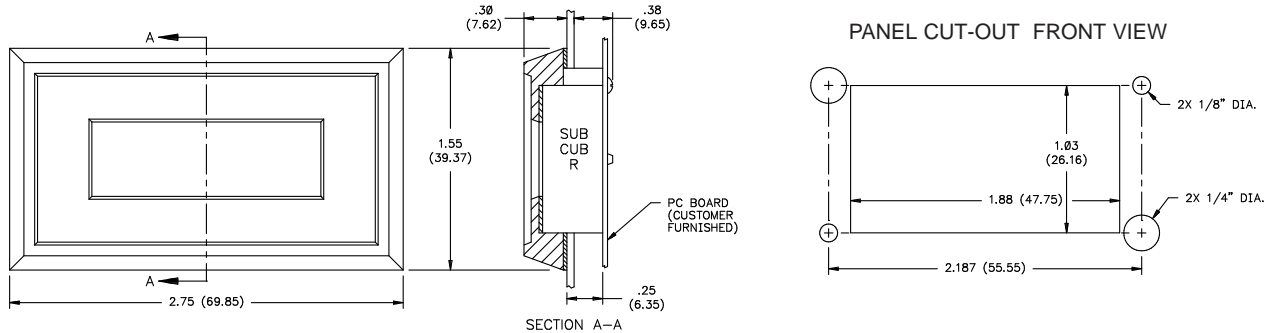

ORDERING INFORMATION

MODEL NO.	DESCRIPTION	PART NUMBER
SCUBR	SUB-CUB Rate Indicator Module	SCUBR200
HWK 6	*Panel Bezel Kit with P.C. Board & Cable	HWK60000
-	*Prototype P.C. Board	DMOSCB04

* Does not include SUB-CUB-R Display/Rate Indicator Module.
Order SUB-CUB-R separately.