

NC4 Flat type
(PC board type)



NC2 Flat type
(PC board type)



NC4 Slim type
(Plug-in type)



NC2 Slim type
(PC board type)

FEATURES

1. Compact, slim design

Use of high-performance flat electromagnetic design achieves 10.9 mm .429 inch profile, flat type thin package. Slim type, with width of 11.2 mm .441 inch, enables high-density mounting on PC boards.

2. High reliability

Provides stable contact pressure needed for card lift-off contact driver method. The use of Ac clad twin contacts provides stable contact resistance and ensures high contact reliability.

3. Compatible with all major safety standards

UL and CSA certified, and complies with Japanese Electrical Appliance and Material Control Law.

4. Socket and terminal are available.

TYPICAL APPLICATIONS

1. Information processing and telecom equipment such as computers and terminal devices.
2. Gas hot air heating equipment and air conditioners.
3. Timer, temperature controller and other equipment that requires form factor reduction.
4. Transmission and measuring devices such as facsimile machines and electronic counting devices.
5. Control panels for industrial equipment such as machine tools, factory automation devices, and NC machines.

Compliance with RoHS Directive

ORDERING INFORMATION

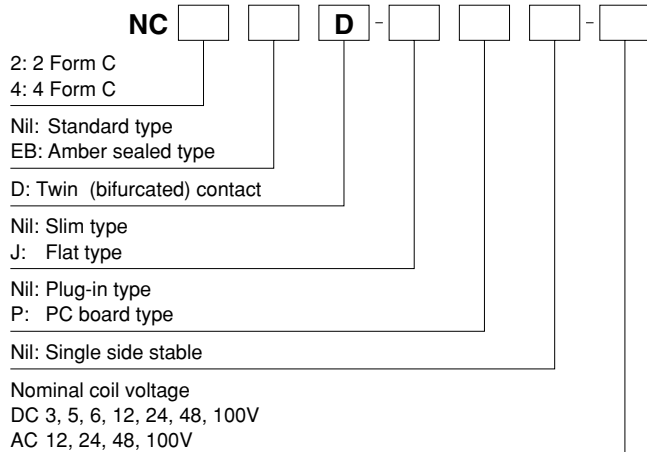

Notes: 1. Certified by UL and CSA
2. Amber sealed types are sealed and filled with inert gas (nitrogen gas).
Sealed construction with terminals, case and base sealed shut with sealing resin.

TYPES

1. Standard type

1) Flat type

Contact arrangement	Nominal coil voltage	PC board type	
		Plug-in type	Part No.
2 Form C	12V AC	NC2D-JP-AC12V	NC2D-JP-AC12V
	24V AC	NC2D-JP-AC24V	NC2D-JP-AC24V
	48V AC	NC2D-JP-AC48V	NC2D-JP-AC48V
	100V AC	NC2D-JP-AC100V	NC2D-JP-AC100V
	3V DC	NC2D-JP-DC3V	NC2D-JP-DC3V
	5V DC	NC2D-JP-DC5V	NC2D-JP-DC5V
	6V DC	NC2D-JP-DC6V	NC2D-JP-DC6V
	12V DC	NC2D-JP-DC12V	NC2D-JP-DC12V
	24V DC	NC2D-JP-DC24V	NC2D-JP-DC24V
	48V DC	NC2D-JP-DC48V	NC2D-JP-DC48V
4 Form C	100V DC	NC2D-JP-DC100V	NC2D-JP-DC100V
	12V AC	NC4D-JP-AC12V	NC4D-JP-AC12V
	24V AC	NC4D-JP-AC24V	NC4D-JP-AC24V
	48V AC	NC4D-JP-AC48V	NC4D-JP-AC48V
	100V AC	NC4D-JP-AC100V	NC4D-JP-AC100V
	3V DC	NC4D-JP-DC3V	NC4D-JP-DC3V
	5V DC	NC4D-JP-DC5V	NC4D-JP-DC5V
	6V DC	NC4D-JP-DC6V	NC4D-JP-DC6V
	12V DC	NC4D-JP-DC12V	NC4D-JP-DC12V
	24V DC	NC4D-JP-DC24V	NC4D-JP-DC24V
4 Form C	48V DC	NC4D-JP-DC48V	NC4D-JP-DC48V
	100V DC	NC4D-JP-DC100V	NC4D-JP-DC100V

Standard packing: Carton: 20 pcs.; Case: 200 pcs.

2) Slim type

Contact arrangement	Nominal coil voltage	Plug-in type		PC board type	
		Plug-in type	Part No.	PC board type	Part No.
2 Form C	12V AC	NC2D-AC12V	NC2D-AC12V	NC2D-P-AC12V	NC2D-P-AC12V
	24V AC	NC2D-AC24V	NC2D-AC24V	NC2D-P-AC24V	NC2D-P-AC24V
	48V AC	NC2D-AC48V	NC2D-AC48V	NC2D-P-AC48V	NC2D-P-AC48V
	100V AC	NC2D-AC100V	NC2D-AC100V	NC2D-P-AC100V	NC2D-P-AC100V
	3V DC	NC2D-DC3V	NC2D-DC3V	NC2D-P-DC3V	NC2D-P-DC3V
	5V DC	NC2D-DC5V	NC2D-DC5V	NC2D-P-DC5V	NC2D-P-DC5V
	6V DC	NC2D-DC6V	NC2D-DC6V	NC2D-P-DC6V	NC2D-P-DC6V
	12V DC	NC2D-DC12V	NC2D-DC12V	NC2D-P-DC12V	NC2D-P-DC12V
	24V DC	NC2D-DC24V	NC2D-DC24V	NC2D-P-DC24V	NC2D-P-DC24V
	48V DC	NC2D-DC48V	NC2D-DC48V	NC2D-P-DC48V	NC2D-P-DC48V
4 Form C	100V DC	NC2D-DC100V	NC2D-DC100V	NC2D-P-DC100V	NC2D-P-DC100V
	12V AC	NC4D-AC12V	NC4D-AC12V	NC4D-P-AC12V	NC4D-P-AC12V
	24V AC	NC4D-AC24V	NC4D-AC24V	NC4D-P-AC24V	NC4D-P-AC24V
	48V AC	NC4D-AC48V	NC4D-AC48V	NC4D-P-AC48V	NC4D-P-AC48V
	100V AC	NC4D-AC100V	NC4D-AC100V	NC4D-P-AC100V	NC4D-P-AC100V
	3V DC	NC4D-DC3V	NC4D-DC3V	NC4D-P-DC3V	NC4D-P-DC3V
	5V DC	NC4D-DC5V	NC4D-DC5V	NC4D-P-DC5V	NC4D-P-DC5V
	6V DC	NC4D-DC6V	NC4D-DC6V	NC4D-P-DC6V	NC4D-P-DC6V
	12V DC	NC4D-DC12V	NC4D-DC12V	NC4D-P-DC12V	NC4D-P-DC12V
	24V DC	NC4D-DC24V	NC4D-DC24V	NC4D-P-DC24V	NC4D-P-DC24V
4 Form C	48V DC	NC4D-DC48V	NC4D-DC48V	NC4D-P-DC48V	NC4D-P-DC48V
	100V DC	NC4D-DC100V	NC4D-DC100V	NC4D-P-DC100V	NC4D-P-DC100V

Standard packing: Carton: 20 pcs.; Case: 200 pcs.

NC

2. Amber type

1) Flat type

Contact arrangement	Nominal coil voltage	PC board type	
		Part No.	
2 Form C	3V DC	NC2EBD-JP-DC3V	
	5V DC	NC2EBD-JP-DC5V	
	6V DC	NC2EBD-JP-DC6V	
	12V DC	NC2EBD-JP-DC12V	
	24V DC	NC2EBD-JP-DC24V	
	48V DC	NC2EBD-JP-DC48V	
	100V DC	NC2EBD-JP-DC100V	
4 Form C	3V DC	NC4EBD-JP-DC3V	
	5V DC	NC4EBD-JP-DC5V	
	6V DC	NC4EBD-JP-DC6V	
	12V DC	NC4EBD-JP-DC12V	
	24V DC	NC4EBD-JP-DC24V	
	48V DC	NC4EBD-JP-DC48V	
	100V DC	NC4EBD-JP-DC100V	

Standard packing: Carton: 20 pcs.; Case: 200 pcs.

2) Slim type

Contact arrangement	Nominal coil voltage	Plug-in type	PC board type
		Part No.	Part No.
2 Form C	3V DC	NC2EBD-DC3V	NC2EBD-P-DC3V
	5V DC	NC2EBD-DC5V	NC2EBD-P-DC5V
	6V DC	NC2EBD-DC6V	NC2EBD-P-DC6V
	12V DC	NC2EBD-DC12V	NC2EBD-P-DC12V
	24V DC	NC2EBD-DC24V	NC2EBD-P-DC24V
	48V DC	NC2EBD-DC48V	NC2EBD-P-DC48V
	100V DC	NC2EBD-DC100V	NC2EBD-P-DC100V
4 Form C	3V DC	NC4EBD-DC3V	NC4EBD-P-DC3V
	5V DC	NC4EBD-DC5V	NC4EBD-P-DC5V
	6V DC	NC4EBD-DC6V	NC4EBD-P-DC6V
	12V DC	NC4EBD-DC12V	NC4EBD-P-DC12V
	24V DC	NC4EBD-DC24V	NC4EBD-P-DC24V
	48V DC	NC4EBD-DC48V	NC4EBD-P-DC48V
	100V DC	NC4EBD-DC100V	NC4EBD-P-DC100V

Standard packing: Carton: 20 pcs.; Case: 200 pcs.

* For sockets, see page 88.

RATING

1. Coil data

1) Single side stable type (AC)

No. of poles	Nominal coil voltage	Pick-up voltage (at 20°C 68°F)	Drop-out voltage (at 20°C 68°F)	Nominal operating current [±10%] (at 20°C 68°F)	Coil inductance		Nominal operating power	Max. applied voltage (at 50°C 122°F)
					N.C. condition	N.O. condition		
2 Form C	12V AC	80%V or less of nominal voltage (Initial)	10%V or more of nominal voltage (Initial)	41.5mA	—	—	0.50VA	110%V of nominal voltage
	24V AC			22.5mA	—	—	0.54VA	
	48V AC			14.0mA	—	—	0.67VA	
	100V AC			10.5mA	—	—	1.05VA	
4 Form C	12V AC	80%V or less of nominal voltage (Initial)	10%V or more of nominal voltage (Initial)	92mA	—	—	1.10VA	110%V of nominal voltage
	24V AC			45mA	—	—	1.08VA	
	48V AC			22.5mA	—	—	1.08VA	
	100V AC			13.0mA	—	—	1.30VA	

2) Single side stable (DC)

No. of poles	Nominal coil voltage	Pick-up voltage (at 20°C 68°F)	Drop-out voltage (at 20°C 68°F)	Nominal operating current [±10%] (at 20°C 68°F)	Coil resistance [±10%] (at 20°C 68°F)	Nominal operating power	Coil inductance		Max. applied voltage (at 50°C 122°F)*
							N.C. condition	N.O. condition	
2 Form C	3V DC	80%V or less of nominal voltage (Initial)	10%V or more of nominal voltage (Initial)	120mA	25Ω	360mW	24.2mH	30.0mH	135%V of nominal voltage
	5V DC			72mA	69.4Ω	360mW	69.5mH	86.0mH	
	6V DC			60mA	100Ω	360mW	99.4mH	123mH	
	12V DC			30mA	400Ω	360mW	388mH	480mH	
	24V DC			15mA	1,600Ω	360mW	1,590mH	1,970mH	
	48V DC			7.5mA	6,400Ω	360mW	6,270mH	7,680mH	
	100V DC			7.4mA	13,500Ω	740mW	9,470mH	11,700mH	110%V of nominal voltage
4 Form C	3V DC	80%V or less of nominal voltage (Initial)	10%V or more of nominal voltage (Initial)	240mA	12.5Ω	720mW	12.8mH	15.8mH	110%V of nominal voltage
	5V DC			144mA	34.7Ω	720mW	34.3mH	42.4mH	
	6V DC			120mA	50Ω	720mW	50.7mH	62.7mH	
	12V DC			60mA	200Ω	720mW	203mH	252mH	
	24V DC			30mA	800Ω	720mW	812mH	1,000mH	
	48V DC			15mA	3,200Ω	720mW	2,820mH	3,480mH	
	100V DC			7.4mA	13,500Ω	740mW	14,100mH	17,400mH	

* At 20°C 68°F (Amber type)

2. Specifications

Characteristics	Item	Specifications				
		DC		AC		
		Single side stable	Single side stable	Single side stable	Single side stable	
Contact	Arrangement	2 Form C		4 Form C		
	Contact resistance (Initial)	Max. 50 mΩ (By voltage drop 6 V DC 1A)		Max. 50 mΩ (By voltage drop 6 V DC 1A)		
	Contact material	Au-clad AgNi type		Au-clad AgNi type		
Rating	Nominal switching capacity (resistive load)	Standard: 5A 250V AC, 5A 30V DC Amber: 3A 250V AC, 5A 30V DC		Standard: 4A 250V AC, 5A 30V DC Amber: 2A 250V AC, 5A 30V DC		
	Max. switching power (resistive load)	Standard: 1,250VA, 150W Amber: 750VA, 150W		Standard: 1,000VA, 150W Amber: 500VA, 150W		
	Max. switching voltage	250 V AC				
	Max. switching current	Standard: 5A Amber: 3A (AC), 5A (DC)		Standard: 4A Amber: 2A (AC), 5A (DC)		
	Nominal operating power	360mW (740mW: 100V DC)	0.50VA to 1.05VA	720mW*2	1.08VA to 1.30VA	
	Min. switching capacity (Reference value)*1	100μA 1V DC		100μA 1VDC		
	Electrical characteristics	Insulation resistance (Initial)	Min. 100MΩ (at 500V DC) Measurement at same location as "Breakdown voltage" section.			
Breakdown voltage (Initial)		Between open contacts	1,000 Vrms for 1min. (Detection current: 10mA.)			
		Between contact sets	1,000 Vrms for 1min. (Detection current: 10mA.)			
		Between contact and coil	2,000 Vrms for 1min. (Detection current: 10mA.)			
Temperature rise (coil)		Max. 65°C [Max. 85°C (100V AC)] (By resistive method, nominal coil voltage)				
Operate time (at 20°C 68°F)		Max. 20ms	Max. 30ms*3	Max. 20ms	Max. 30ms*3	
Release time (at 20°C 68°F)	Max. 10ms	Max. 40ms*3	Max. 10ms	Max. 40ms*3		
Mechanical characteristics	Shock resistance	Functional	Min. 98 m/s ² (Half-wave pulse of sine wave: 11 ms; detection time: 10μs.)			
		Destructive	Min. 980 m/s ² (Half-wave pulse of sine wave: 6 ms.)			
	Vibration resistance	Functional	10 to 55 Hz at double amplitude of 1 mm (Detection time: 10μs.)			
	Destructive	10 to 55 Hz at double amplitude of 2 mm				
Expected life	Mechanical	Min. 5×10 ⁷	Min. 10 ⁷	Min. 5×10 ⁷	Min. 10 ⁷	
	Electrical (resistive load)	Standard: Min. 10 ⁵ (5A 250V AC), Min. 5×10 ⁵ (5A 30V DC) Amber: Min. 10 ⁵ (3A 250V AC), Min. 5×10 ⁵ (5A 30V DC)		Standard: Min. 10 ⁵ (4A 250V AC), Min. 5×10 ⁵ (5A 30V DC) Amber: Min. 10 ⁵ (2A 250V AC), Min. 5×10 ⁵ (5A 30V DC)		
Conditions	Conditions for operation, transport and storage*4 (Not freezing and condensing at low temperature)	-40°C to +70°C -40°F to +158°F (Max. 48V DC), -40°C to +55°C -40°F to +131°F (100V DC)	-40°C to +60°C -40°F to +140°F*5	-40°C to +55°C -40°F to +131°F	-40°C to +40°C -40°F to +104°F	
	Max. Operating speed	50 cps				
Unit weight	16 g .56 oz			18 g .63 oz		

Notes: *1 This value can change due to the switching frequency, environmental conditions, and desired reliability level, therefore it is recommended to check this with the actual load.

*2. 100V DC: 740mW

*3. For the AC type, the operate and release time differs depending on the phase of the input and cutoff times.

*4. The upper limit of the ambient temperature is the maximum temperature that can satisfy the coil temperature rise value. Refer to Usage, transport and storage conditions in NOTES.

*5. 100V DC: -40°C to +40°C -40°F to +104°F

REFERENCE DATA (Standard type)

1.-(1) Life curve
(AC/DC load 2 Form C, 4 Form C)

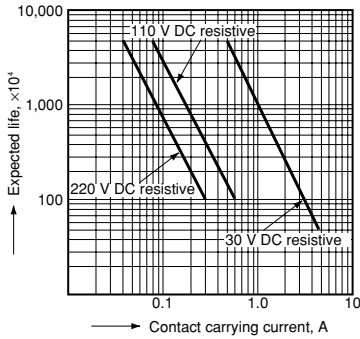

1.-(2) Life curve (AC/DC load 2 Form C)

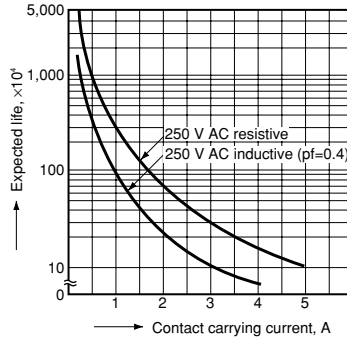

1.-(3) Life curve (AC/DC load 4 Form C)

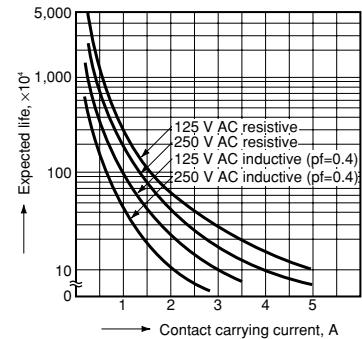

2. Temperature rise characteristics
(single side stable)

Measured portion: Inside the coil

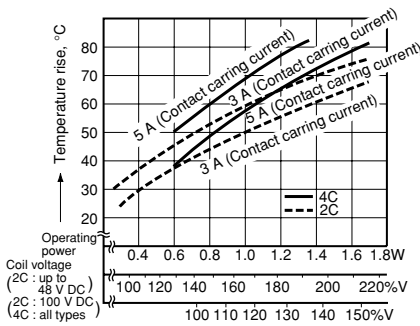

3. Operate time (single side stable)

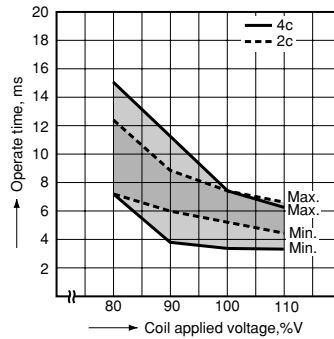

4. Release time (single side stable)

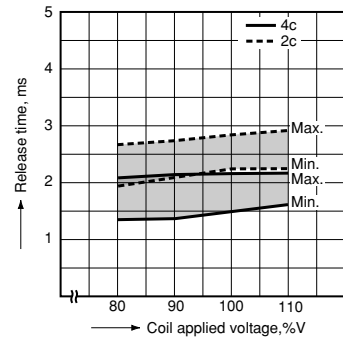

5.-(1) Rate of change of pick-up and drop-out voltage
(2 Form C single side stable)

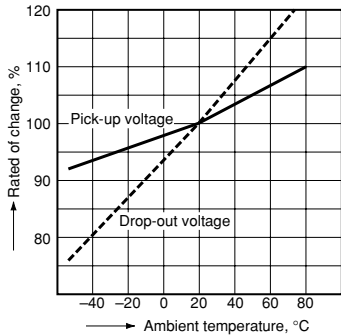

5.-(2) Rate of change of pick-up and drop-out voltage
(4 Form C single side stable)

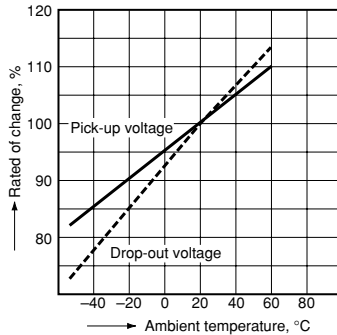

6.-(1) Ambient temperature vs Max. applied voltage

Tested sample:
NC2D-P-DC24 V (2 Form C slim single side stable)

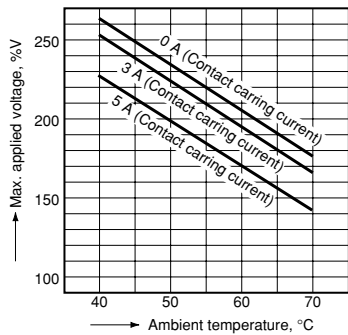

6.-(2) Ambient temperature vs Max. applied voltage

Tested sample:
NC2D-P-DC110 V (2 Form C slim single side stable),
NC4D-P-DC24 V (4 Form C slim single side stable)

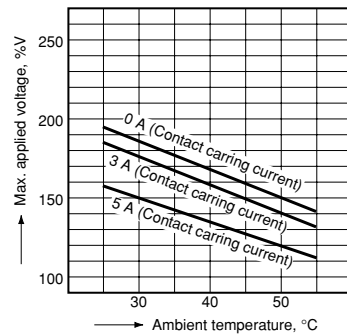

DIMENSIONS (mm inch)

The CAD data of the products with a **CAD Data** mark can be downloaded from: <http://panasonic-electric-works.net/ac>

<Standard type>

Flat type
2 Form C

CAD Data



External dimensions

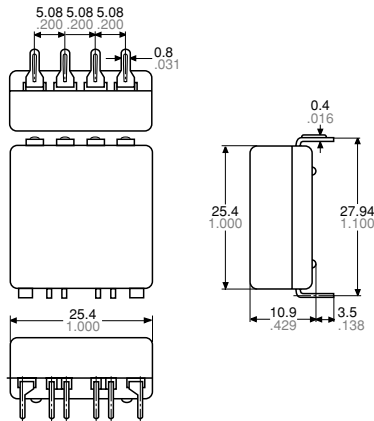

Schematic (Top view)
Single side stable

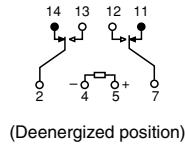

PC board pattern (Bottom view)
Single side stable

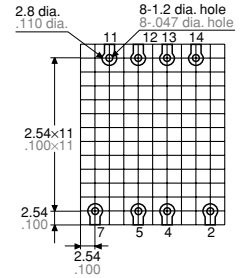

Flat type
4 Form C

CAD Data

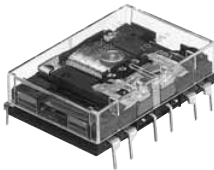

External dimensions

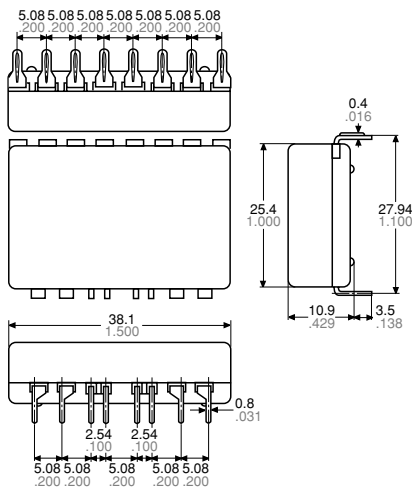

Schematic (Top view)
Single side stable

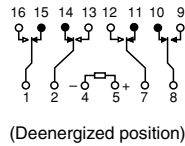

PC board pattern (Bottom view)
Single side stable

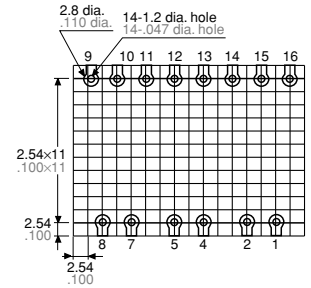

Slim type
Plug-in type
2 Form C

CAD Data



External dimensions

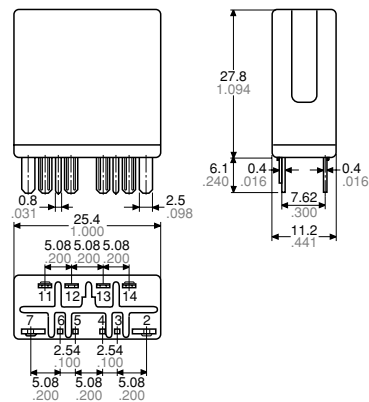

Schematic (Bottom view)
Single side stable

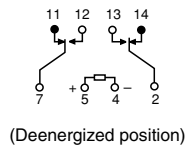

NC

Slim type
Plug-in type
4 Form C

CAD Data

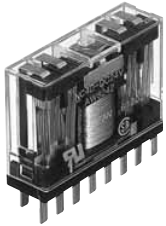

External dimensions

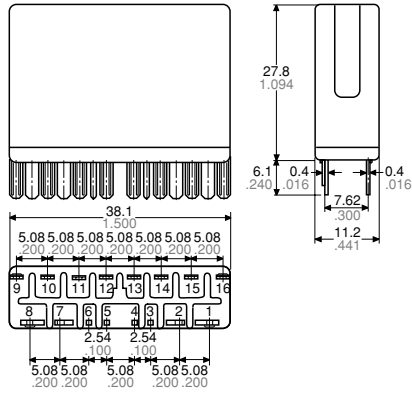

Schematic (Bottom view)

Single side stable

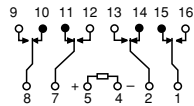

(Deenergized position)

Slim type
PC board type
2 Form C

CAD Data



External dimensions

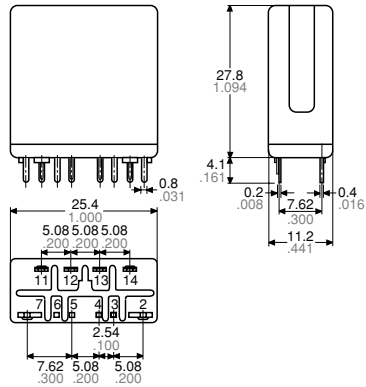

(Dowel heigh: 0.4 .016)

Schematic (Bottom view)

Single side stable

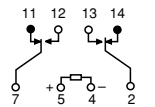

(Deenergized position)

PC board pattern (Bottom view)

Single side stable

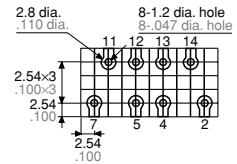

Slim type
PC board type
4 Form C

CAD Data

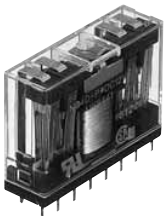

External dimensions

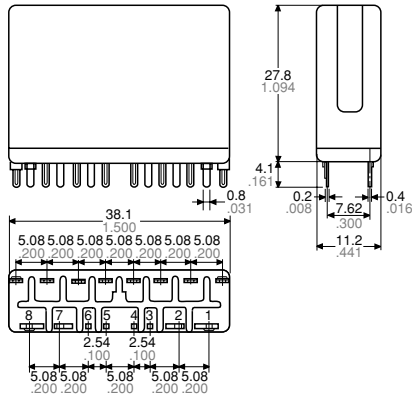

(Dowel heigh: 0.4 .016)

Schematic (Bottom view)

Single side stable

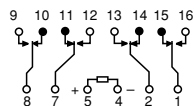

(Deenergized position)

PC board pattern (Bottom view)

Single side stable

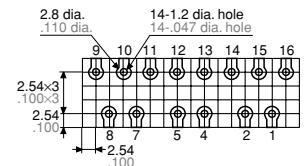

<Amber sealed type>

Flat type

2 Form C

CAD Data



External dimensions

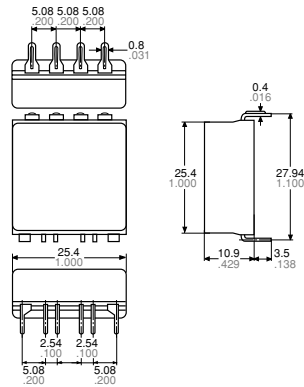

Schematic (Top view)

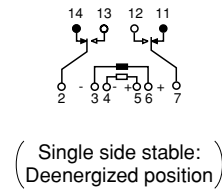

PC board pattern (Bottom view)

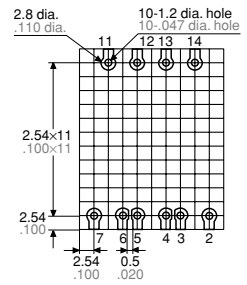

Flat type

4 Form C

CAD Data



External dimensions

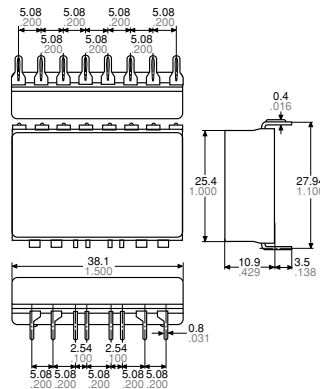

Schematic (Top view)

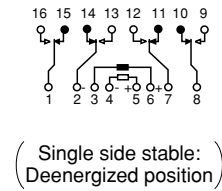

PC board pattern (Bottom view)

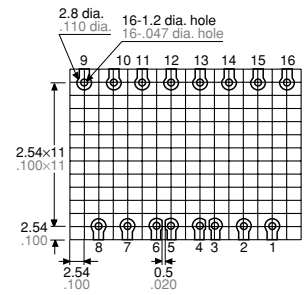

Slim type

Plug-in type

2 Form C

CAD Data



External dimensions

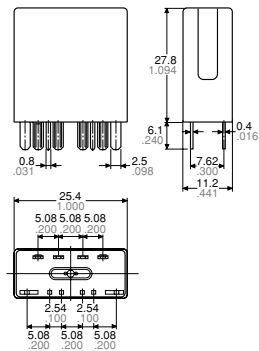

Schematic (Bottom view)

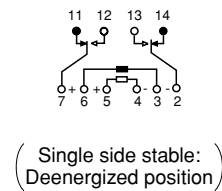

NC

Slim type
Plug-in type
4 Form C

CAD Data

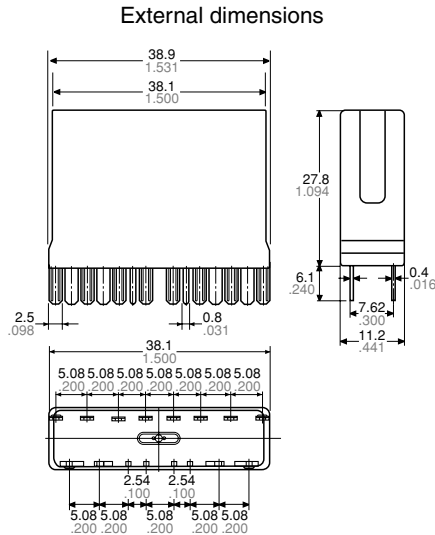

Schematic (Bottom view)

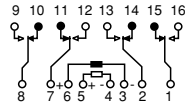

(Single side stable:
Deenergized position)

Slim type
PC board type
2 Form C

CAD Data

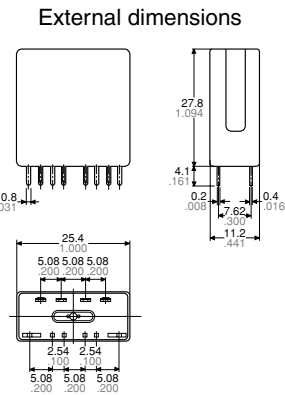

Schematic (Bottom view)

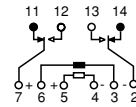

(Single side stable:
Deenergized position)

PC board pattern (Bottom view)

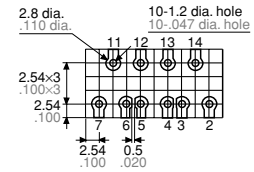

Slim type
PC board type
4 Form C

CAD Data

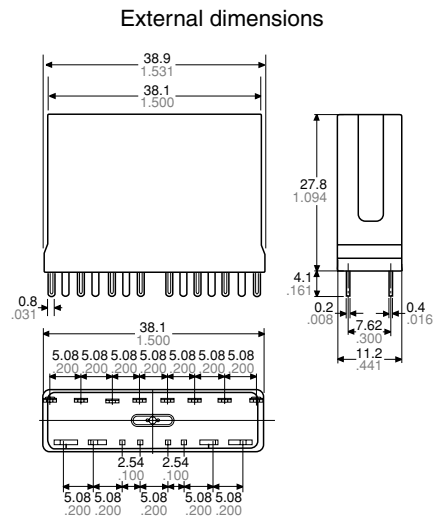

Schematic (Bottom view)

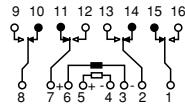

(Single side stable:
Deenergized position)

PC board pattern (Bottom view)

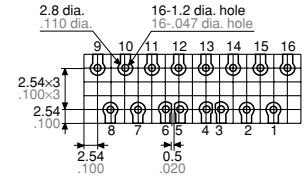

SAFETY STANDARDS

Product name		UL/C-UL (Recognized)		CSA (Certified)		VDE (Certified)	
		File No.	Contact rating	File No.	Contact rating	File No.	Contact rating
NC	2 Form C	E43028	5A 250V AC 1/10HP 125, 250V AC 5A 30V DC	LR26550 etc.	5A 250V AC 1/10HP 125, 250V AC 5A 30V DC	1004	5A 125V AC (cosφ=1.0) 1A 125V AC (cosφ=0.4) 5A 30V DC (0ms)
	4 Form C	E43028	5A 125V AC 4A 250V AC 1/10HP 125, 250V AC 5A 30V DC	LR26550 etc.	5A 125V AC 4A 250V AC 1/10HP 125, 250V AC 5A 30V DC	1004	5A 125V AC (cosφ=1.0) 1A 125V AC (cosφ=0.4) 5A 30V DC (0ms)
NC Amber	2 Form C	E43028	3A 250V AC 1/20HP 125, 250V AC 5A 30V DC	LR26550 etc.	3A 250V AC 1/20HP 125, 250V AC 5A 30V DC	1005	1A 125V AC (cosφ=1.0) 0.5A 125V AC (cosφ=0.4) 1A 30V DC (0ms)
	4 Form C	E43028	2A 250V AC 1/20HP 125, 250V AC 5A 30V DC	LR26550 etc.	2A 250V AC 1/20HP 125, 250V AC 5A 30V DC	1005	1A 125V AC (cosφ=1.0) 0.5A 125V AC (cosφ=0.4) 1A 30V DC (0ms)

NOTES

1. Because the NC relay is polarized, the positive “+” and negative “-” connections to the coil should be done as indicated on the wiring diagram. If connected incorrectly, it may malfunction or fail to operate.
2. While NC relays can be used with any transmission-wave current to their operation, due to slight weakening of the force of magnetic attraction, decreased resistance to vibration and shock should be taken into account.
3. The current that energizes the coil in an NC relay is AC type. Because the AC sine waveform is distorted, when testing, it is essential to use a measuring device that can properly characterize the distorted waveform.
The operating power of the coil in the 100 V AC 4 Form C type is relatively higher than other NC types of AC relay and consequently, the total current applied through all the contacts should be kept below 10 A.
4. The AC type NC relay has a special magnetic design. As a result, once the a-side contacts have switched, the b-side contacts may once again go into a temporary ON state depending on the coil inrush phase. To ensure that this phenomenon does not occur, it is necessary to carry out sufficient practical testing with relays installed in actual devices.

5. When designing top and bottom view schematic diagrams, note that:
 - 1) “Top view” wiring diagram is indicated for the flat series because terminals can be seen from above.
 - 2) “Bottom view” schematic diagram is indicated for the vertical series because terminals cannot be seen from above.

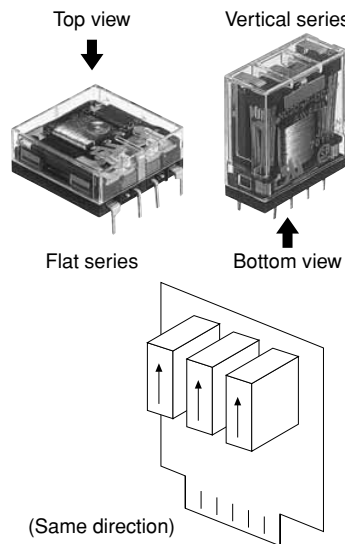

6. Cautions for close proximity mounting
When using slim series in close proximity, mount all relays facing the same direction. Different mounting directions may cause change in the relay characteristics because NC relays are polarized.

For Cautions for Use.

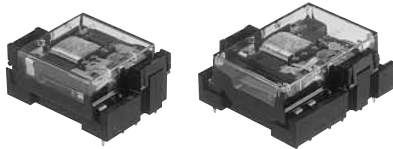

NC2 Flat type socket



NC4 Flat type socket



NC2 Slim type socket



NC4 Slim type socket



NC2 DIN terminal socket

FEATURES

• **Socket**

1) The vertical (slim) type with solder terminals has a retainer, which enables snap-in fixing on chassis, panels, and similar locations. Because the sockets for both solder terminals and PC boards firmly fix the relay at the time of insertion, once snapped in, spring clips are unnecessary.

2) For the flat type, pull up the hinged clasps in the direction of the arrows shown in the drawing after inserting the relay. Spring clips are unnecessary.

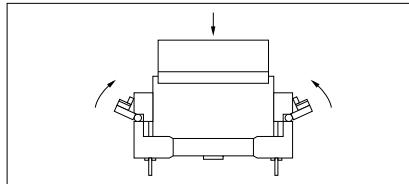

Compliance with RoHS Directive

TYPES

	Product name	Terminals	Part No.
Flat type socket	NC2-flat type PC board socket	P/C board	NC2-JPS
	NC4-flat type PC board socket	P/C board	NC4-JPS
Slim type terminal socket	NC2-DIN terminal socket	DIN rail	NC2-SFD
	NC2-slim type socket	Solder	NC2-SS
Slim type socket	NC2-slim type PC board socket	P/C board	NC2-PS
	NC2-slim type wrapping socket	Lead wire	NC2-WS
	NC4-slim type socket	Solder	NC4-SS
	NC4-slim type PC board socket	P/C board	NC4-PS
	NC4-slim type wrapping socket	Lead wire	NC4-WS

SPECIFICATIONS (common)

Item	Specifications
Max. continuous current	Slim type: 5A 250V AC, Flat type: 5A 250V AC
Initial breakdown voltage	2,000 V AC (Except for coil to coil of L2 type: 1,500 V AC)
Initial insulation resistance	Min. 100MΩ (at 500V DC megger)
Heat resistance	150°C 302°F for 1 hour

Note: Do not insert or remove relays while in the energized condition.

DIMENSIONS (mm inch)

The CAD data of the products with a **CAD Data** mark can be downloaded from: <http://panasonic-electric-works.net/ac>

Flat type socket for PC board
NC2-JPS

CAD Data

External dimensions

Terminal portion

PC board pattern

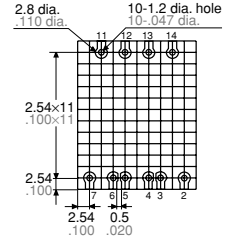
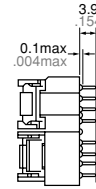
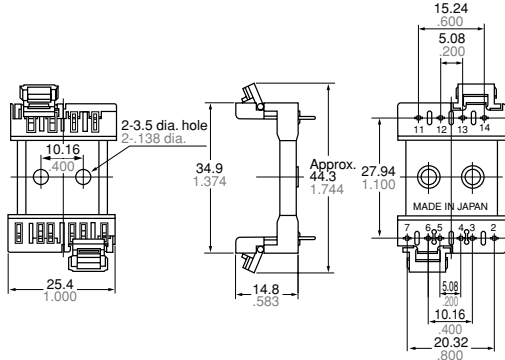

Note: Terminals 3 and 6 excluded for NC2-JPS.

Flat type socket for PC board
NC4-JPS

CAD Data

External dimensions

Terminal portion

PC board pattern

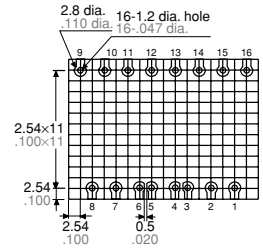
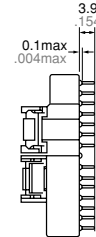
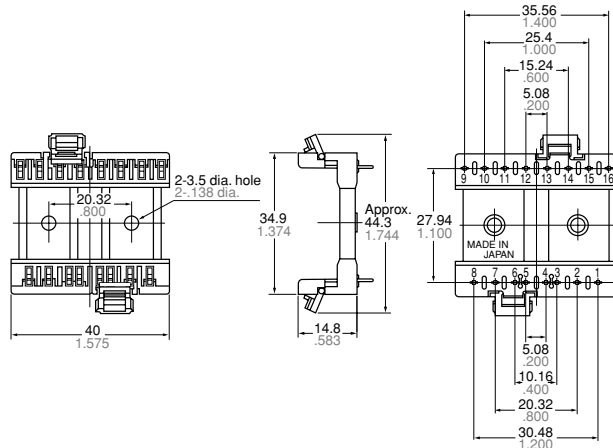

Note: Terminals 3 and 6 excluded for NC4-JPS.

Slim type DIN terminal socket
NC2-SFD

CAD Data

External dimensions

Mounting hole diagram

Schematic

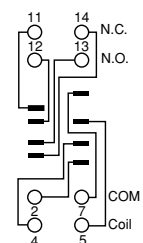
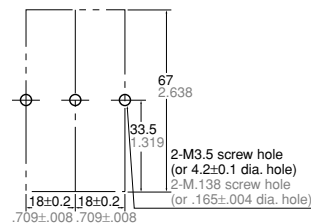
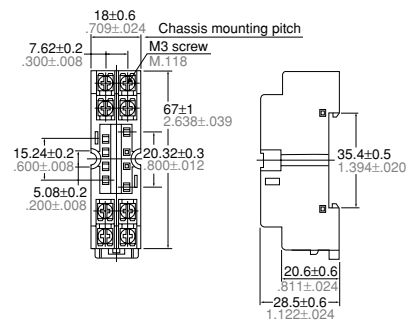
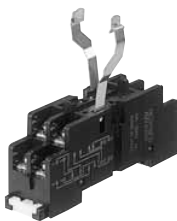

(Retaining springs are included with the DIN terminal socket.)

*To prevent damage or distortion, when tightening fixing screws, the optimum torque range should be 0.49 to 0.69 N·m, (5 to 7 kgf·cm).

NC

Slim type socket for solder terminal NC2-SS

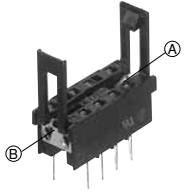

CAD Data

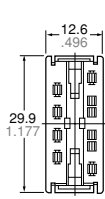

External dimensions

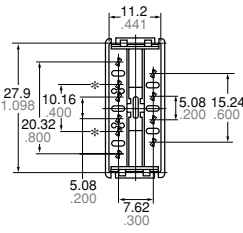
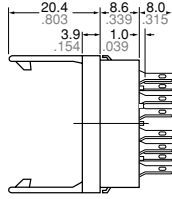

Chassis cutout

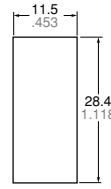

- Notes: 1. Suitable chassis thickness is 1.0 to 2.0 mm .039 to .079 inch.
2. Once the socket is inserted from above into the mounting holes, the relay will snap in to clips rising from either side at (A) and (B) by pushing.

Note: NC2-SS is as shown in the diagram above except that terminals marked with "*" are not present.

Slim type socket for solder terminal NC4-SS

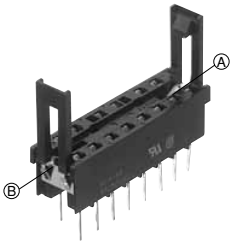

CAD Data

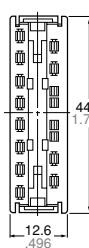

External dimensions

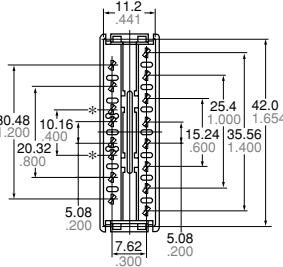
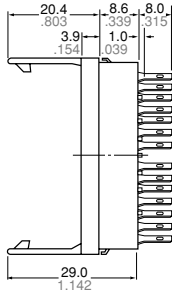

Chassis cutout

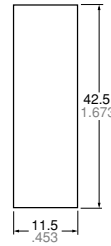

- Notes: 1. Suitable chassis thickness is 1.0 to 2.0 mm .039 to .079 inch.
2. Once the socket is inserted from above into the mounting holes, the relay will snap in to clips rising from either side at (A) and (B) by pushing.

Note: NC4-SS is as shown in the diagram above except that terminals marked with "*" are not present.

Slim type socket for PC board NC2-PS



CAD Data

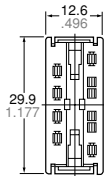

External dimensions

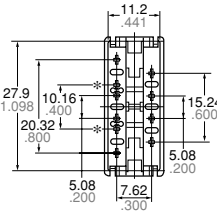
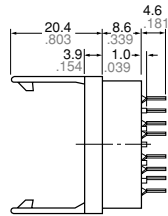

PC board pattern

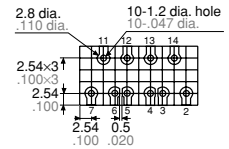

Note: NC2-PS is as shown in the diagram at left except that terminals marked with "*" are not present.

Slim type socket for PC board NC4-PS



CAD Data

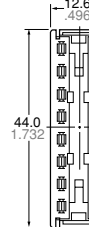

External dimensions

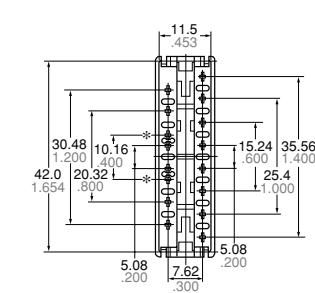
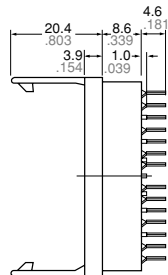

PC board pattern

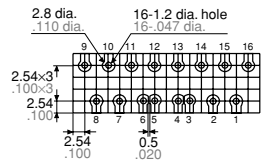

Note: NC4-PS is as shown in the diagram at left except that terminals marked with "*" are not present.

**Vertical (Slim) type
wrapping socket
NC2-WS**



CAD Data

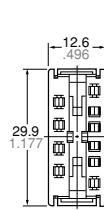

External dimensions

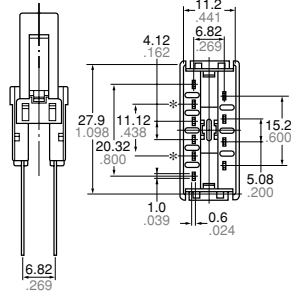
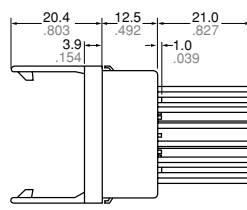

Terminal cross section

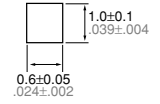

Chassis cutout

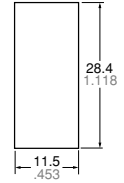

Note: NC2-WS is as shown in the diagram above except that terminals marked with “*” are not present.

**Vertical (Slim) type
wrapping socket
NC4-WS**



CAD Data

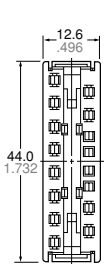

External dimensions

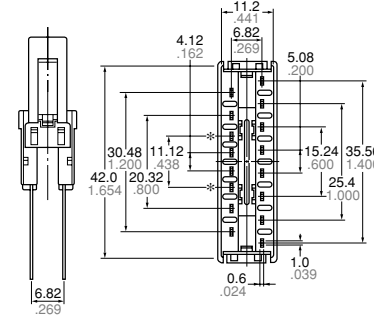
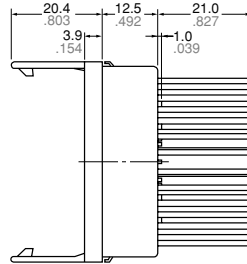

Chassis cutout

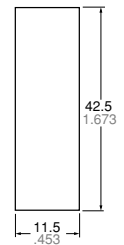

Note: NC4-WS is as shown in the diagram above except that terminals marked with “*” are not present.

NOTES

1. Soldering should be done quickly to avoid damaging the thermoplastic body.
2. For solder terminal types, connect terminals as shown in the diagram at right to maintain insulation distance.

