



POF-40022



POF-40048



POF-40059

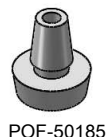

POF-50185



POF-12664

PART NO.	RECOMMENDED MOUNTING HOLE	RECOMMENDED PANEL THICKNESS	"A" DIA.	"B" DIA.	"C" DIA.	"D"	"E"	"F" REF	STYLE NO.
POF-40022	.146-.150 [3.7-3.8]	.126 [3.2]	.31 [7.9]	.126 [3.2]	.17 [4.4]	.13 [3.3]	.06 [1.6]	.13 [3.3]	1
POF-40048	.177-.181 [4.5-4.6]	.059 [1.5]	.31 [7.9]	.146 [3.7]	.24 [6.1]	.06 [1.6]	.09 [2.3]	.12 [3]	1
POF-40059	.374-.378 [9.5-9.6]		.50 [12.7]	.374 [9.5]	.50 [12.7]	.06 [1.6]	.48 [12.2]	.14 [3.6]	2
POF-50185	.236-.240 [6-6.1]	.075 [1.9]	.53 [13.4]	.236 [6]	.29 [7.3]	.08 [2]	.18 [4.6]	.34 [8.6]	3
POF-12664	.276-.280 [7-7.1]	.047 [1.2]	.62 [15.7]	.276 [7]	.34 [8.6]	.05 [1.3]	.20 [5.1]	.16 [4.1]	3

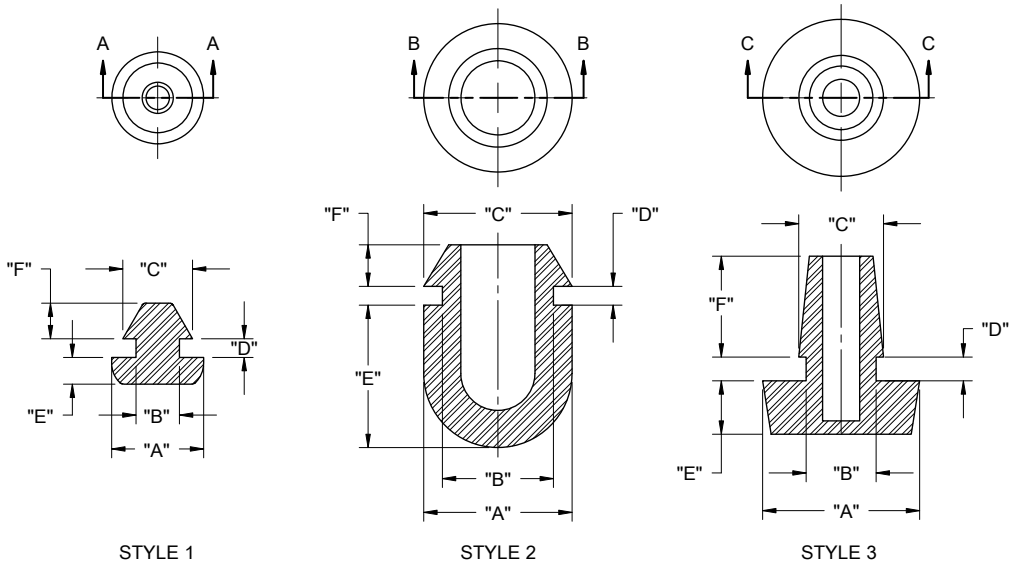

- NOTES:
 1. MATERIAL: THERMOPLASTIC ELASTOMER, UL 94 HB (RMS-262)
 2. COLOR: BLACK

TITLE: PUSH ON FEET			UNITS= INCH [mm]		FINAL		PRINT TYPE	
CREATED USING SOLIDWORKS	FILE #: POF	DWN: SK	APP: R.T.	PART #		PRINT TYPE		
TOLERANCES UNLESS NOTED .XX=±.010 .XXX=±.005 FRAC.=±1/64 ANG.=±1°	SHEET: 1 OF 1 SHEET SIZE: A	DT: 11/06/06	CHKD: S.J.	SEE TABLE		CA		
RE: RICHCO, INC.	RICHCO, INC. ENG@RICHCO-INC.COM (773) 539-4060							
REV. DESCRIPTION	ENGR. DATE							