

PART NO.	"A"
REHCBS-4-01	1/4 (6.4)
REHCBS-5-01	5/16 (7.9)
REHCBS-6-01	3/8 (9.5)
REHCBS-8-01	1/2 (12.7)
REHCBS-11-01	11/16 (17.5)
REHCBS-12-01	3/4 (19.1)
REHCBS-14-01	7/8 (22.2)
REHCBS-16-01	1 (25.4)
REHCBS-19.2-01	1.2 (30.5)
REHCBS-20-01	1.25 (31.8)

TO SNAP LOCK IN A
 $.157 \pm .003$ (4.00 \pm 0.08)
 DIA. HOLE, IN A $.070$
 (1.78) MAX. THICK BOARD

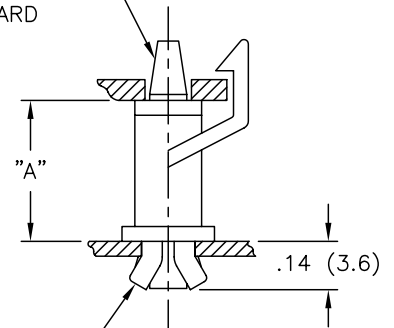

TO FIT A $.187 \pm .003$ (4.75 \pm 0.08)
 DIA. HOLE, IN A $.047$ TO $.105$
 (1.20 TO 2.67) THICK PANEL

NOTES:
 1. MATERIAL: NYLON 66.
 2. COLOR: NATURAL.

E	REMOVED P/N: REHCBS-10.4-01 AND CHANGED FILE NO. AND TITLE BLOCK	SM 06.19.01	TITLE: RIVET EDGE HOLD CIRCUIT BOARD SUPPORT			DWG IN (MM) FINAL			
D	PANEL THICKNESS WAS .047 TO .090	SM 10.13.00	TOLERANCES UNLESS NOTED	FILE # REHCBS	DWN: P.B.	APP:			
C	P/N'S REHCBS-10.4, 11, 19.2, & 20 ADDED	PB 11.10.94	.XX= \pm .010	MAT'L: SEE NOTES	DT: 03-10-94	DT:	PART #	PRINT TYPE	
B	CONVERTED TO ACAD; RECOMMENDED HOLE LOCATION REMOVED; DIMS REVISED	PB 03.10.94	.XXX= \pm .005	RE: RICHCO, INC.	RICHCO INC. PO BOX 804238, CHICAGO, 60680 (773) 539-4060		SEE TABLE	CA	
A	TOLERANCES REVISED	RS 08.03.92	FRAC= \pm 1/64						
REV	DESCRIPTION	ENGR DATE	ANG= \pm 1'						