

PART NO.	"A"
REHCBS-4-01	1/4 [6.4]
*REHCBS-5-01	5/16 [7.9]
REHCBS-8-01	1/2 [12.7]
*REHCBS-12-01	3/4 [19.1]

*AVAILABLE BY SPECIAL ORDER ONLY.

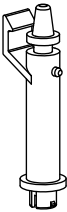
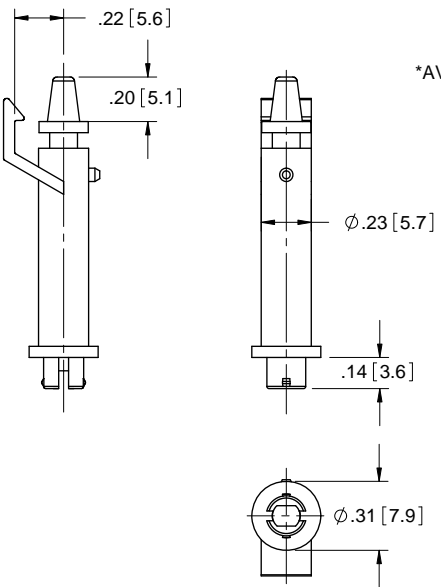
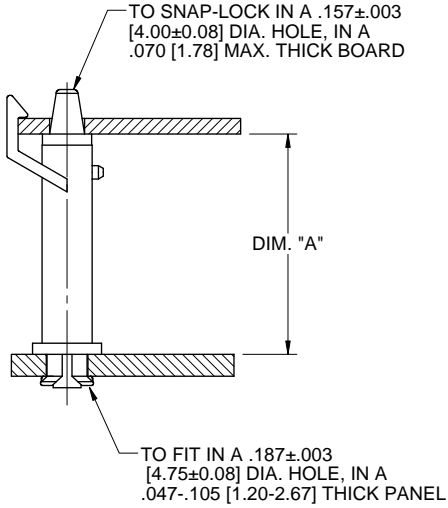

NOTES:
 1. MATERIAL: NYLON 6/6 (RMS-01)
 2. COLOR: NATURAL

REV.			TITLE: RIVET EDGE HOLD CIRCUIT BOARD SUPPORT			DWG IN IN [MM]		FINAL		PRINT TYPE	
L	SEE CO 200604 FOR CHANGES	SK 12/01/10	CREATED USING SOLIDWORKS	FILE #: REHCBS	DWN: SK	APP: -	PART #	SEE TABLE	CA		
K	UNOBSOLETE REHCBS-12, SEE CO 200571	SK 08/05/10	TOLERANCES UNLESS NOTED	SHEET: 1 OF 1	SHEET SIZE: A	DT: 03/04/05					
J	SEE CO 200041 FOR CHANGES	SK 09/28/07	.XX±.010	RE: RICHCO, INC.	RICHCO, INC.		ENG@RICHCO-INC.COM		(773) 539-4060		
I	SEE ECN #957 FOR CHANGES	SK 03/04/05	.XX±.005								
-	SEE ENGINEERING FOR REV. A-H	--	FRAC.=±1/64								
REV.	DESCRIPTION	ENGR. DATE	ANG.=±1°								