

UBM (FIGURE 1)	*UBMC (FIGURE 2)	DIM. "A"
PART NO.	PART NO.	
UBM-12.3M-01	*UBMC-12.3M-01	.48 [12.3]
UBM-15.5M-01	*UBMC-15.5M-01	.61 [15.5]
UBM-22.0M-01	*UBMC-22.0M-01	.87 [22]

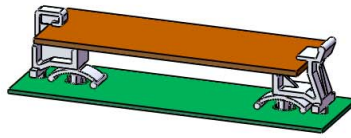
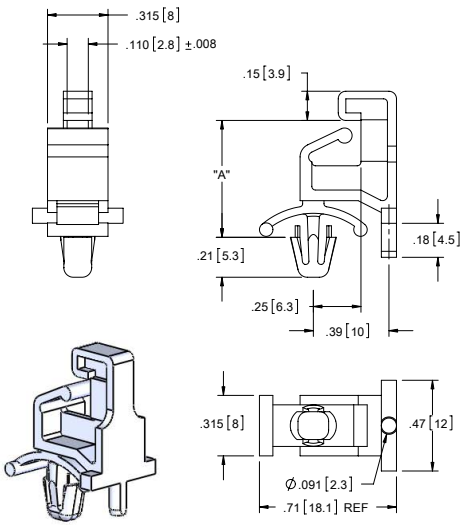

FIGURE 1



MOUNTING LAYOUT

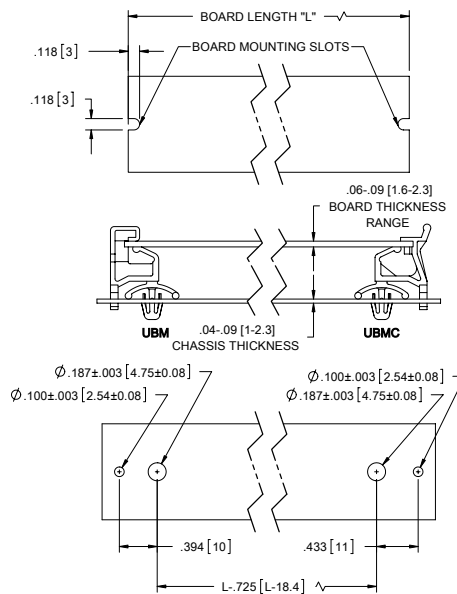
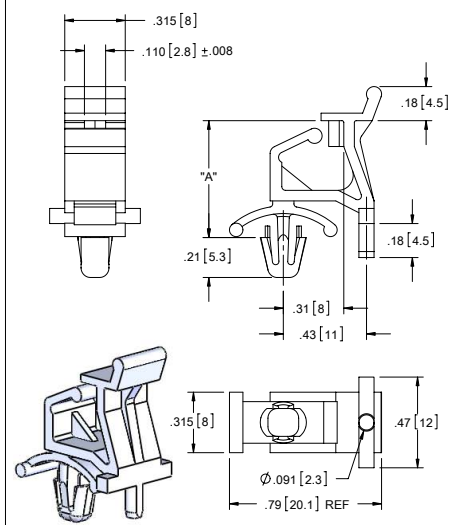

FIGURE 2



\*PARTS AVAILABLE BY SPECIAL ORDER ONLY

NOTES:  
 1. MATERIAL: NYLON 6/6 UL 94 V-2 (RMS-01)  
 2. COLOR: NATURAL

TITLE: UNIVERSAL BOARD MOUNT (CLIP)				DWG IN IN [MM]		FINAL		PRINT TYPE	
CREATED:UBM(C)	FILE #: UBM(C)	DWN: SK	APP: RT						
SHEET: 1 OF 1	SHEET SIZE: B	DT: 10/11/06	CHKD: SJ						
RE: RICHCO, INC.	RICHCO, INC.		ENG@RICHCO-INC.COM		(773) 539-4060		PART #		CA
SEE TABLE									

REV.	DESCRIPTION	ENGR.	DATE
B	SEE ECN #1277 FOR CHANGES	SK	01/23/07
A	NEW DRAWING. SEE ECN #1221 FOR CHANGES	SK	10/12/06
-	SEE ENGINEERING FOR REVISION HISTORY	-	-