

MATERIAL: NYLON 6/6 UL 94 V-2 (RMS-01) PART NO.	DIM. "A"±.015 [0.4]
LCBSM-2-01	1/8 [3.2]
LCBSM-3-01	3/16 [4.8]
LCBSM-4-01	1/4 [6.4]
LCBSM-5-01	5/16 [7.9]
LCBSM-6-01	3/8 [9.5]
LCBSM-7-01	7/16 [11.1]
LCBSM-8-01	1/2 [12.7]
LCBSM-9-01	9/16 [14.3]
LCBSM-10-01	5/8 [15.9]

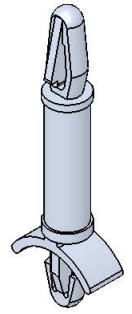
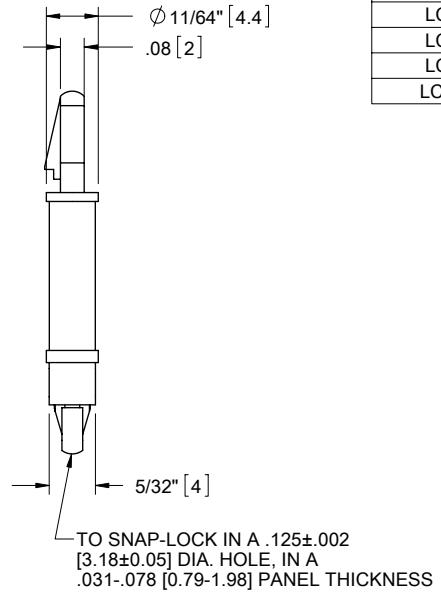
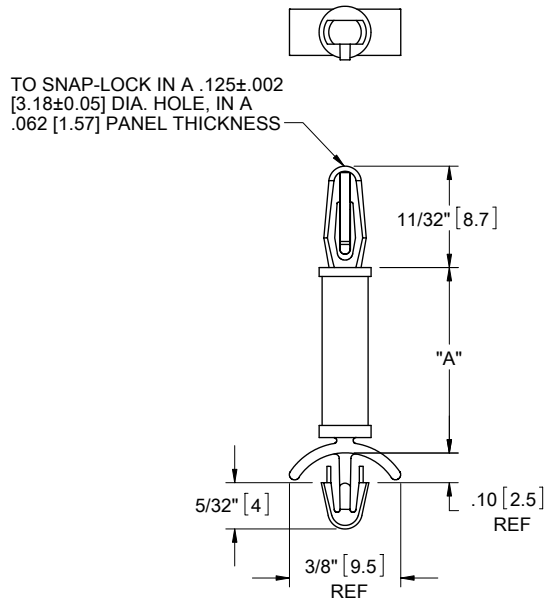

- NOTES:
1. MATERIAL: NYLON 6/6 UL 94 V-0 (RMS-19), AVAILABLE BY SPECIAL ORDER. TO ORDER REPLACE "-01" WITH "-19".
  2. COLOR: NATURAL.
  3. ALTERNATE UNITS FOR REFERENCE ONLY.

TITLE: LOCKING CIRCUIT BOARD SUPPORT, MINI		DWG IN IN [MM]		FINAL			
CREATED USING SOLIDWORKS	FILE #: LCBSM	DWN: SK	APP: RT	PART #		PRINT TYPE	
TOLERANCES UNLESS NOTED .XX±.010 .XXX±.005 FRAC.=±1/64 ANG.=±1°	SHEET: 1 OF 1	SHEET SIZE: A	DT: 09/01/06	CHKD: SJ	SEE TABLE		CA
RE: RICHCO, INC.	RICHCO, INC.		ENG@RICHCO-INC.COM (773) 539-4060				

E	SEE ECN #1287 FOR CHANGES	SK	02/13/07
D	SEE ECN #1208 FOR CHANGES	SK	11/29/06
-	SEE ENGINEERING FOR REV. A TO C	-	---
REV.	DESCRIPTION	ENGR.	DATE