

PART NO.	"A"±.015 (±0.4)	"B"±.015 (±0.4)	"C"±.015 (±0.4)	HOLE DIA. ±.003 (±0.08)	PANEL THICKNESS
BHC-3-01	3/16 (4.8)	7/16 (11.1)	5/16 (7.9)	.312 (7.92)	1/4 (6.4) MIN.
BHC-4-01	1/4 (6.4)				
BHC-6-01	3/8 (9.5)				
BHC-8-01	1/2 (12.7)				
BHC-10-01	5/8 (15.9)				
BHC-12-01	3/4 (19.1)				
BHC-14-01	7/8 (22.2)				
*BHC1-3-01	3/16 (4.8)	3/8 (9.5)	17/64 (6.7)	.250 (6.35)	1/4 (6.4) MIN.
*BHC1-4-01	1/4 (6.4)				
*BHC1-6-01	3/8 (9.5)				
*BHC1-8-01	1/2 (12.7)				
*BHC1-10-01	5/8 (15.9)				
*BHC1-12-01	3/4 (19.1)				
*BHC1-14-01	7/8 (22.2)				

*PARTS AVAILABLE BY SPECIAL ORDER ONLY

TO SNAP-FIT IN $.156 \pm .003$
(4.00±0.08) DIA. HOLE IN A
.062 (1.57) THICK BOARD.

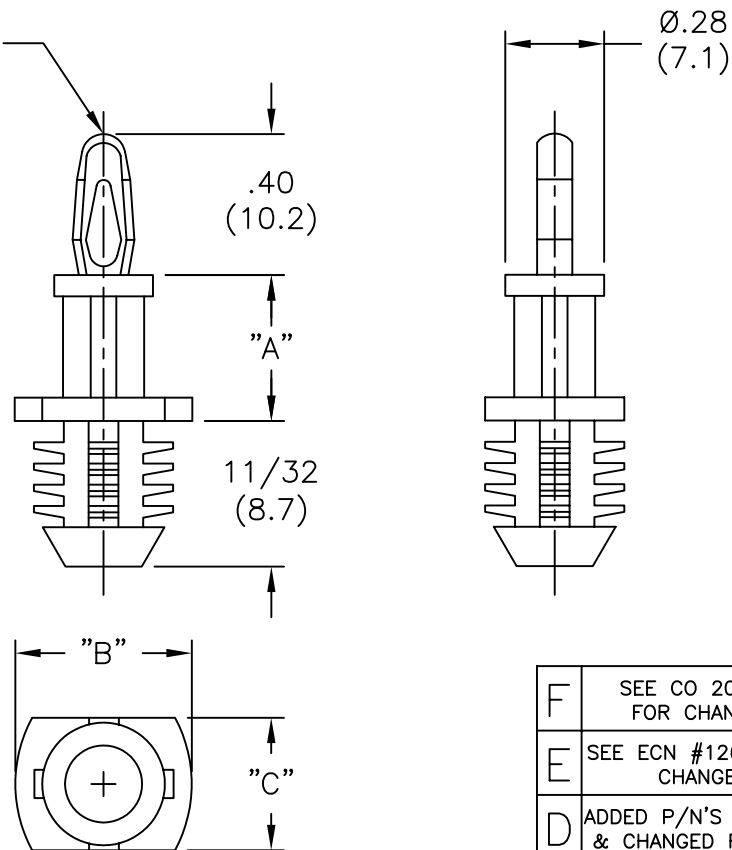

NOTES:

- MATERIAL: NYLON 6/6 UL 94 V-2 (RMS-01).
NYLON 6/6 UL 94 V-0 (RMS-19),
AVAILABLE BY SPECIAL ORDER ONLY.
- COLOR: NATURAL.

F	SEE CO 200035 FOR CHANGES	SK 09.26.07
E	SEE ECN #1262 FOR CHANGES	SK 12.11.06
D	ADDED P/N'S BHC1-... & CHANGED FILE NO.	S.M. 08.13.01
C	MAT'L RMS-19 ADDED	J.L. 12.18.97
B	FILES SEPARATED AND GIVEN FILE NUMBERS	J.B. 08.31.95
A	DIMS' ON LEADERS CHANGED TO MATCH STANDARD	P.B. 06.19.95
R E V	DESCRIPTION	ENGR DATE

TITLE: BLIND HOLE CKT. BD. SUPPORT (BHC)

TOLERANCES UNLESS NOTED .XX=±.010 .XXX=±.005 FRAC=±1/64 ANG=±1°	FILE # BHC	DWN: R.S.	APP:	DWG IN IN (MM)	FINAL	PART # SEE TABLE	PRINT TYPE CA
	MAT'L: SEE NOTES	DT: 10-08-93	DT:				
	RE: RICHCO, INC.	RICHCO INC. PO BOX 804238, CHICAGO, 60680 (773) 539-4060					