

MATERIAL: NYLON 6/6 UL 94 V-2 (RMS-01) COLOR: NATURAL PART NO.	DIM. "A" ±.015 [0.4]
PSM-2-01	1/8 [3.2]
PSM-3-01	3/16 [4.8]
PSM-4-01	1/4 [6.4]
PSM-5-01	5/16 [7.9]
PSM-6-01	3/8 [9.5]
PSM-7-01	7/16 [11.1]
PSM-8-01	1/2 [12.7]
PSM-9-01	9/16 [14.3]
PSM-10-01	5/8 [15.9]

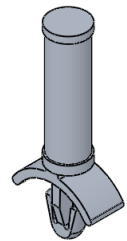
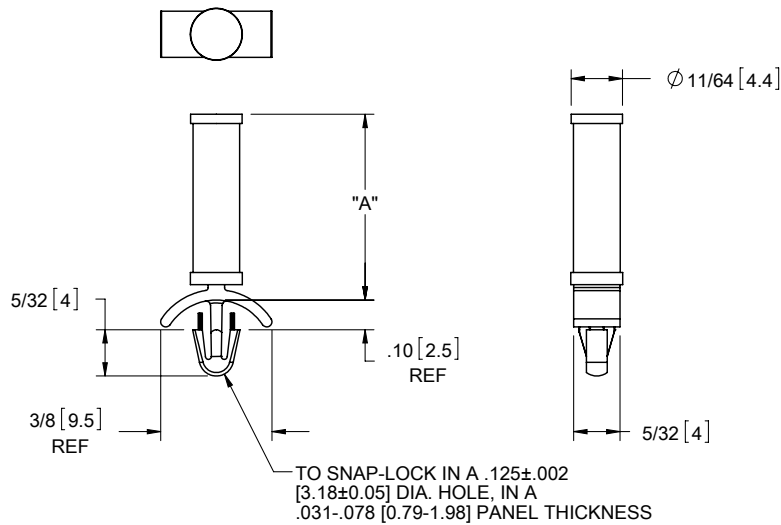

NOTES:

1. MATERIAL: NYLON 6/6 UL 94 V-0 (RMS-19)
COLOR: NATURAL.
AVAILABLE BY SPECIAL ORDER ONLY.
2. OTHER COLORS AVAILABLE BY SPECIAL ORDER.
3. ALTERNATE UNITS FOR REFERENCE ONLY.

TITLE: PUSH SPACER, MINI			
CREATED USING SOLIDWORKS	FILE #: PSM	DWN: SK	APP: RT
TOLERANCES UNLESS NOTED .XX±.010 .XXX±.005 FRAC.=1/64 ANG.=±1°	SHEET: 1 OF 1	SHEET SIZE: A	DT: 11/29/06
RE: RICHCO, INC.	RICHCO, INC. ENG@RICHCO-INC.COM (773) 539-4060		CHKD: SJ
E : SEE ECN #1345 FOR CHANGES	SK	07/23/07	PART # SEE TABLE
D : REDRAWN, SEE ECN #1208 FOR CHANGES	SK	11/29/06	
- : SEE ENGINEERING FOR REVISIONS A-C	---	----	
REV. : DESCRIPTION	ENGR.	DATE	
PRINT TYPE CA			