

TO SNAP-LOCK IN A .156±.003
[4±0.08] DIA. HOLE, IN A
.062 [1.57] PANEL THICKNESS

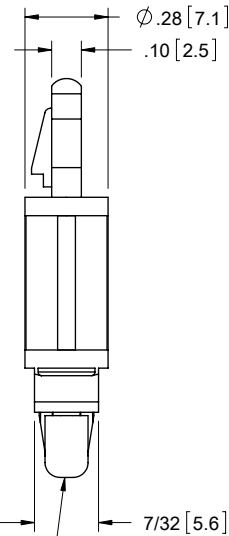

TO SNAP-LOCK IN A .187±.003
[4.75±0.08] DIA. HOLE, IN A
.031-.078 [0.79-1.98] PANEL THICKNESS

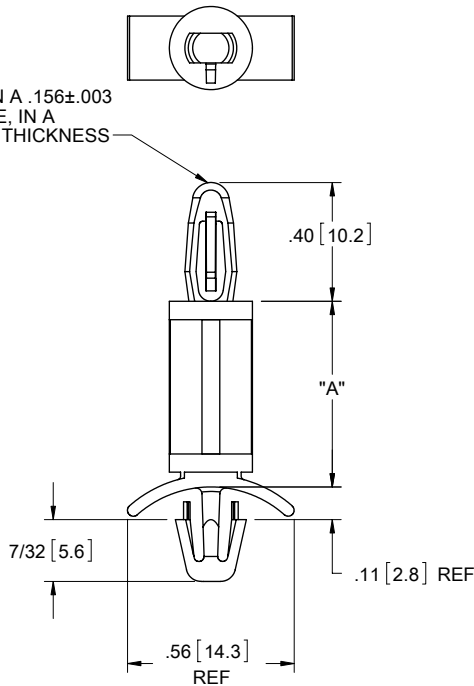
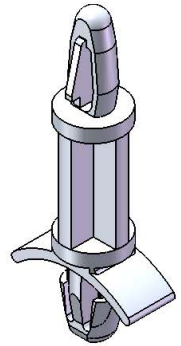

MATERIAL: NYLON 6/6 UL 94 V-2 (RMS-01) COLOR: NATURAL PART NO.	MATERIAL: NYLON 6/6 UL 94 V-0 (RMS-19) COLOR: NATURAL PART NO.	DIM. "A"±.015 [0.4]
LCBS-3-01	LCBS-3-19	3/16 [4.8]
LCBS-4-01	LCBS-4-19	1/4 [6.4]
LCBS-5-01	LCBS-5-19	5/16 [7.9]
LCBS-6-01	LCBS-6-19	3/8 [9.5]
LCBS-7-01	LCBS-7-19	7/16 [11.1]
LCBS-8-01	LCBS-8-19	1/2 [12.7]
LCBS-10-01	LCBS-10-19	5/8 [15.9]
LCBS-12-01	LCBS-12-19	3/4 [19.1]
LCBS-14-01	LCBS-14-19	7/8 [22.2]
LCBS-16-01	LCBS-16-19	1 [25.4]
LCBS-18-01	LCBS-18-19	1-1/8 [28.6]
LCBS-20-01	LCBS-20-19	1-1/4 [31.7]
LCBS-22-01	LCBS-22-19	1-3/8 [34.9]

- NOTES:
1. MATERIAL: NYLON 6/6 UL 94 HB (RMS-73)
COLOR: NATURAL,
AVAILABLE BY SPECIAL ORDER ONLY.
2. MATERIAL: NYLON 4/6 UL 94 V-2 (RMS-109)
COLOR: NATURAL,
AVAILABLE BY SPECIAL ORDER ONLY.
3. ALTERNATE UNITS FOR REFERENCE ONLY.

TITLE: LOCKING CIRCUIT BOARD SUPPORT					DWG IN IN [MM]	
CREATED USING SOLIDWORKS	FILE #: LCBS	DWN: SK	APP: RT	FINAL		
TOLERANCES UNLESS NOTED .XX±.010 .XXX±.005 FRAC.=±1/64 ANG.=±1°	SHEET: 1 OF 1	SHEET SIZE: A	DT: 11/29/06	CHKD: SJ	PART #	PRINT TYPE
	RE: RICHCO, INC.	RICHCO, INC. ENG@RICHCO-INC.COM (773) 539-4060		SEE TABLE	CA	

F	REDRAWN, SEE ECN #1208 FOR CHANGES	SK	11/29/06
-	SEE ENGINEERING FOR REVISIONS A-E	---	----
REV.	DESCRIPTION	ENGR.	DATE