

Customer Information Sheet

DRAWING No.: R40-300XX02 SHEET 2 OF 2 IF IN DOUBT - ASK © NOT TO SCALE THIRD ANGLE PROJECTION ALL DIMENSIONS IN mm

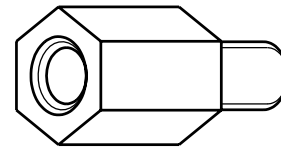
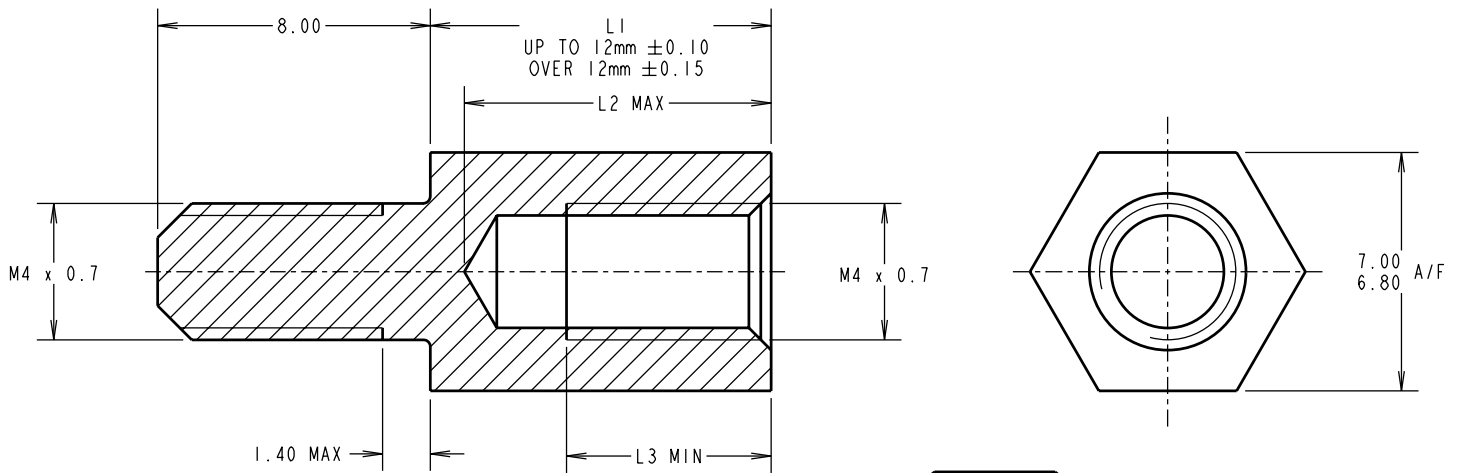

ORDER CODE:
R40-300XX02
LENGTH L1 IN mm

PART No.	L1	L2	L3	PART No.	L1	L2	L3
R40-3000602	6.00	5.3	2.50	R40-3001602	16.00	12.0	8.00
R40-3000702	7.00	6.3	3.50	R40-3001802	18.00	12.0	8.00
R40-3000802	8.00	7.3	4.50	R40-3002002	20.00	12.0	8.00
R40-3000902	9.00	8.3	5.50	R40-3002502	25.00	12.0	8.00
R40-3001002	10.00	9.3	6.50	R40-3003002	30.00	12.0	8.00
R40-3001102	11.00	10.3	8.00	R40-3003502	35.00	12.0	8.00
R40-3001202	12.00	10.8	8.00	R40-3004002	40.00	12.0	8.00
R40-3001302	13.00	12.0	8.00	R40-3004602	46.00	12.0	8.00
R40-3001402	14.00	12.0	8.00	R40-3006302	63.00	12.0	8.00
R40-3001502	15.00	12.0	8.00				

SF	5	09.10.08	10174
NAME	ISS.	DATE	C/NOTE
APPROVED:		SF	
CHECKED:		MGP	
DRAWN:		P. COLLINS	
CUSTOMER REF.:			
ASSEMBLY DRG:			

HARWIN

HARWIN USA
TEL: 603 893 5376
FAX: 603 893 5396
mis@harwin.com

HARWIN Europe (UK)
TEL: 023 9231 4545
FAX: 023 9231 4590
mis@harwin.co.uk

HARWIN Asia
TEL: +65 6 779 4909
FAX: +65 6 779 3868
mis@harwin.com.sg

THIS DRAWING AND ANY INFORMATION OR DESCRIPTIVE MATTER SET OUT HEREON ARE CONFIDENTIAL AND COPYRIGHT PROPERTY OF THE HARWIN GROUP AND MUST NOT BE DISCLOSED, LOANED, COPIED OR USED FOR MANUFACTURING, TENDERING OR FOR ANY OTHER PURPOSE WITHOUT THE IR WRITTEN PERMISSION.

TOLERANCES
X. = ±1mm
X.X = ±0.25mm
X.XX = ±0.10mm
X.XXX = ±0.01mm
ANGLES = ±5°
UNLESS STATED

MATERIAL:
BRASS CW614N M TO BS EN 12164 (CuZn39Pb3)

FINISH: NICKEL

S/AREA: mm²

TITLE:
M4 HEXAGONAL MALE/FEMALE SPACER

DRAWING NUMBER:
R40-300XX02

SHT 2 OF 2