

LENGTH "L"	LENGTH TOLERANCE	PART NO.						
		FOR #4 SCREW (M-2.5)	FOR #6 SCREW (M-3)	FOR #8 SCREW (M-4)	FOR #8 SCREW (M-4)	FOR #10 SCREW	FOR 1/4 BOLT (M-6)	FOR 3/8 BOLT (M-9)
		"A"=.120±.007 [3.0±0.18] "B"=1/4±.007 [6.4±0.18]	"A"=.147±.007 [3.7±0.18] "B"=1/4±.007 [6.4±0.18]	"A"=.175±.007 [4.4±0.18] "B"=1/4±.007 [6.4±0.18]	"A"=.175±.007 [4.4±0.18] "B"=3/8±.007 [9.5±0.18]	"A"=.200±.010 [5.1±0.25] "B"=3/8±.010 [9.5±0.25]	"A"=.266±.010 [6.8±0.25] "B"=1/2±.010 [12.7±0.25]	"A"=.397±.010 [10.1±0.25] "B"=1/2±.010 [12.7±0.25]
1/4 [6.4]	±.015 [±0.38]	SS4-2	SS6-2	SS8-2	SS8-2L	SS10-2	SS1/4-2	SS3/8-2
3/8 [9.5]		SS4-3	SS6-3	SS8-3	SS8-3L	SS10-3	-	SS3/8-3
1/2 [12.7]		SS4-4	SS6-4	SS8-4	SS8-4L	SS10-4	SS1/4-4	SS3/8-4
5/8 [15.9]		SS4-5	SS6-5	SS8-5	SS8-5L	SS10-5	-	-
3/4 [19.1]		SS4-6	SS6-6	SS8-6	SS8-6L	SS10-6	SS1/4-6	SS3/8-6
1 [25.4]		SS4-8	SS6-8	SS8-8	SS8-8L	SS10-8	SS1/4-8	SS3/8-8
1-1/4 [31.8]		SS4-10	SS6-10	SS8-10	SS8-10L	SS10-10	SS1/4-10	*SS3/8-10
1-1/2 [38.1]		SS4-12	SS6-12	SS8-12	SS8-12L	SS10-12	SS1/4-12	*SS3/8-12
1-3/4 [44.5]		*SS4-14	*SS6-14	*SS8-14	*SS8-14L	*SS10-14	*SS1/4-14	*SS3/8-14
2 [50.8]		*SS4-16	*SS6-16	*SS8-16	*SS8-16L	*SS10-16	*SS1/4-16	*SS3/8-16*
2-1/4 [57.2]	±.020 [±0.51]	-	-	*SS8-18	*SS8-18L	*SS10-18	*SS1/4-18	*SS3/8-18
2-1/2 [63.5]		-	-	*SS8-20	*SS8-20L	*SS10-20	*SS1/4-20	*SS3/8-20
2-3/4 [69.9]		-	-	*SS8-22	*SS8-22L	*SS10-22	*SS1/4-22	*SS3/8-22
3 [76.2]		-	-	*SS8-24	*SS8-24L	*SS10-24	*SS1/4-24	*SS3/8-24

\*PARTS AVAILABLE BY SPECIAL ORDER

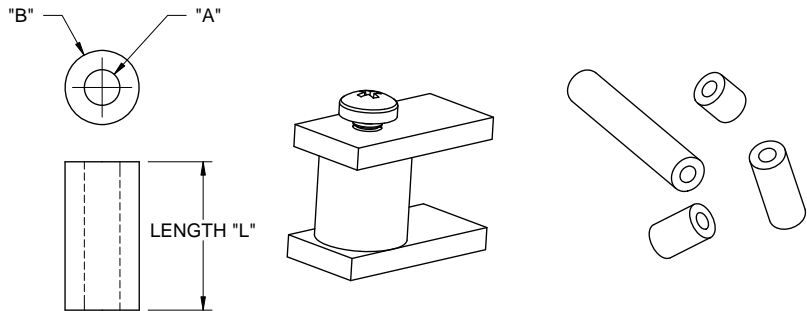

NOTES:  
1. MATERIAL: CPVC, RIGID (RMS-11).  
2. COLOR: LIGHT GRAY.

L	SEE CO 200604 FOR CHANGES	SK	12/01/10	TITLE: <b>ROUND SPACERS SERIES</b>		DWG IN IN [MM]	
K	SEE CO 200077 FOR CHANGES	SK	12/03/07				
J	ECN #1337 FOR CHANGES	SK	07/10/07	FILE #: SS	DWN: SM	APP: -	PART #
I	SEE ECN #968 FOR CHANGES	SK	03/23/05	SHEET: 1 OF 1	SHEET SIZE: A	DT: 07/02/04	
H	SEE ECN #914 FOR CHANGES	SK	01/14/05	RE: RICHCO, INC.	RICHCO, INC.		SEE TABLE
G	SEE ECN #818 FOR CHANGES	SM	10/01/04	CREATED USING SOLIDWORKS	ENG@RICHCO-INC.COM	(773) 539-4060	
F	SEE ECN #816 FOR CHANGES	SM	07/02/04	TOLERANCES UNLESS NOTED .XX±.010 .XXX±.005 FRAC.=±1/64 ANG.=±1°	FINAL		CA
-	SEE ENGINEERING FOR REV. A-E	--	--				
REV.	DESCRIPTION	ENGR.	DATE				