



GE SERIES SNAP-IN MOUNTING HIGH PERFORMANCE IEC CONNECTOR FILTERS



INTRODUCTIONS

1. Snap-in mounting type to reduce labor cost. Compact and reliable at low cost.
2. Bleeder resistor can be added with suffix "-R" on part numbers, except G3H, G3V, W3V, G3J, W3J, types.
3. Optional side snap-in mounting clip type with suffix (H) on part numbers.
4. All part numbers are UL recognized, CSA certified and VDE approved.
5. With optional Y-Cap from 100pF to 3300pF.
6. Safety under apply for 03/06/10GENG3U(H) series.

COMPONENTS

PART NO.	Cx (uF)	L (mH)	Cy (pF)	R (Ω)
01GENG3E/W3E/-R	0.1	6.5	2200	1M
03GENG3E/W3E/G3U(H)-R		2.5		
• 03GENW3ES/-R		2.5		
• 03GENG3Q/W3Q/-R		4		
06GENG3E/W3E/G3U(H)-R		0.8		
••06GENG3Q/W3Q/-R		1.5		
06GENW3ES/-R		0.8		
10GENG3E/W3E/G3U(H)-R		0.2		
•••10GENG3C/W3C/-R		0.4		
* 10GENG3Q/W3Q/-R		0.3		
10GENW3ES/-R		0.2		
**15GENG3E/W3E/-R		0.2		
***20GENG3E/W3E/-R		0.3		

- UL, CSA approved to 4A 115/250V
- UL, CSA approved to 8A 115/250V
- VDE approved to 8A/250V

- * UL, CSA approved to 13A 115/250V
- ** VDE approved to 10A/250V
- *** VDE approved to 16A/250V

MINIMUM INSERTION LOSS IN dB

CURRENT RATING	COMMON MODE (L-G) IN 50 OHM SYSTEM					
	FREQUENCY-MHz					
	.15	.50	1.0	5.0	10	30
1A	28	35	38	38	40	40
3A	20	25	30	38	40	40
6A	12	18	24	35	40	40
6A (G3Q)	15	20	24	35	40	55
10A	4	10	13	28	35	40
10A (G3C)	10	15	15	25	30	35
10A (G3Q)	10	12	15	30	32	45
15A	4	10	13	28	35	40
20A	8	10	15	25	30	35

ELECTRICAL SCHEMATIC

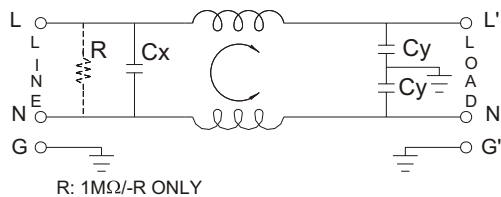

SPECIFICATIONS

1. Maximum leakage current each line-to-ground @ 115VAC 60Hz: 0.2mA @ 250VAC 50Hz: 0.4mA
2. Hipot rating (one minute) line-to-ground: 2250VDC line-to-line: 1450VDC
3. Operating frequency: 50/60Hz
4. Rated voltage: 115/250VAC

INSERTION LOSS (TYPICAL)

03GENG3E ----- COMMON MODE ----- DIFF. MODE
06GENG3E ----- COMMON MODE ----- DIFF. MODE

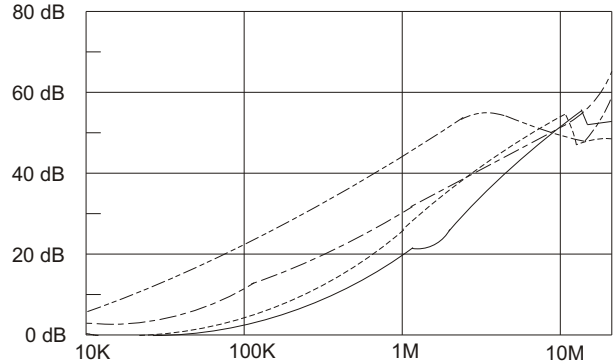

20GENG3E ----- COMMON MODE ----- DIFF. MODE

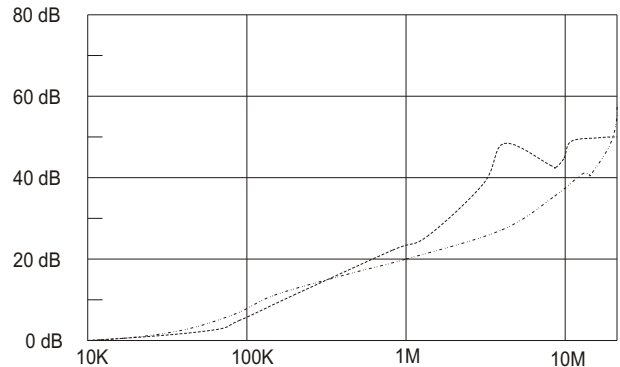

MECHANICAL CONSTRUCTION



NG3E, NG3C, NG3Q (Optional wire type)



NG3E(H), NG3C(H), NG3Q(H) (Optional wire type)



NG3U(H) (With Compact Size)

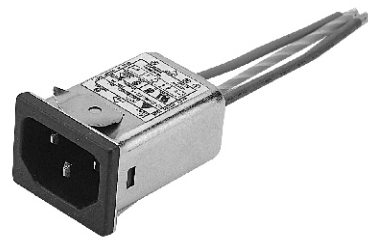

NW3ES

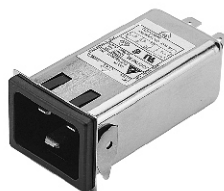

20GENG3E (Optional wire type)

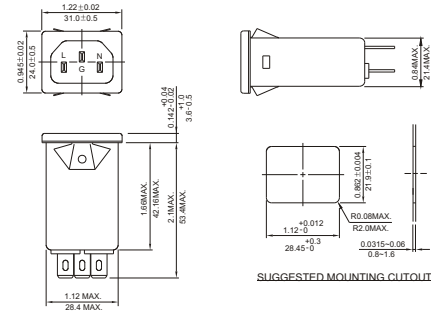
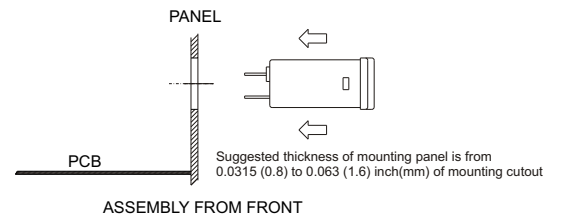

GENG3E

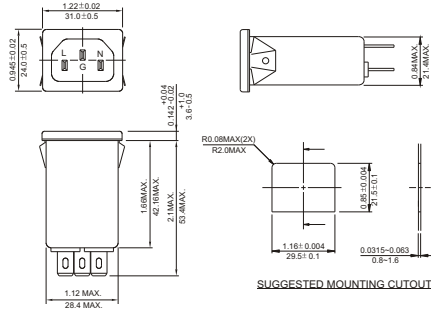

GENG3E(H)

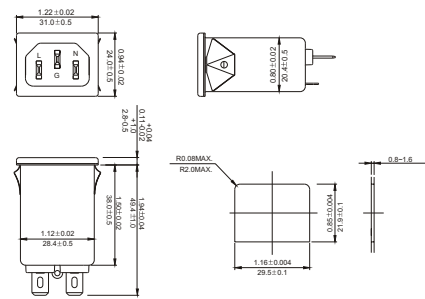

NG3U(H)

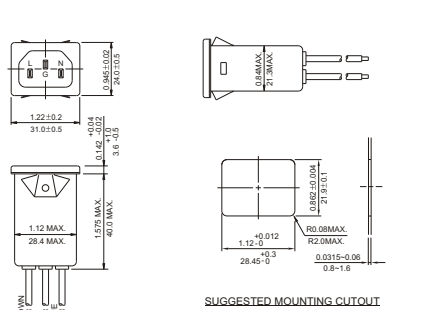

NW3ES

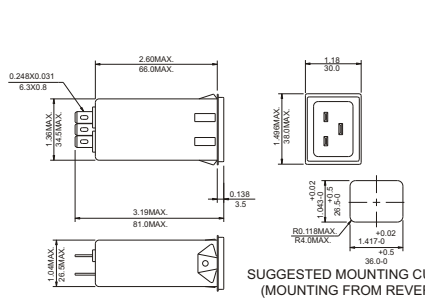

UNIT: $\frac{\text{INCH}}{\text{mm}}$