

Sine wave and EMC output filter for motor drives with a voltage dc link

SCHAFFNER

energy efficiency and reliability



- Smoothing of PWM drive output voltage
- Efficient motor protection
- Reduction of common-mode interferences on motor cables
- Improvement of EMC environment
- Elimination of motor bearing damages
- Possibility to use very long unshielded motor cables
- Improvement of system reliability

Design protected by international patent



Technical specifications

Nominal operating voltage:	3x 500/288VAC
dc link voltage:	850VDC max.
Motor frequency:	0 to 200Hz
Switching frequency:	6 to 20kHz
Rated currents:	4 to 16A @ 40°C
Motor cable length:	1000m max.
Voltage drop:	≤10V @ 50Hz
Current in +/- control loop:	1 to 2A approx.
Residual ripple voltage:	<5%
High potential test voltage:	P → E 2500VDC for 2 sec P → P 1100VDC for 2 sec
Protection category:	IP20
Overload capability:	1.4x rated current for 1 minute, every 15 minutes
Temperature range (operation and storage):	-25°C to +100°C (25/100/21)
Flammability corresponding to:	UL 94V-2 or better
Design corresponding to:	UL 1283, CSA 22.2 No. 8 1986, IEC/EN 60939
MTBF @ 40°C/400V (Mil-HB-217F):	>100,000 hours



Features and benefits

- Conversion of the PWM output signal (differential and common-mode voltage components) of motor drives into a smooth sine wave with low residual ripple.
- Elimination of premature motor damage caused by high dv/dt, overvoltages, motor overheating, eddy current losses or bearing damage.
- Elimination of interference propagation towards components or conductors in the vicinity.
- Provision of all benefits of traditional LC sine wave filters, plus:
- Allows the use of extremely long unshielded motor cables without causing radiation problems (EN 55014, MDS clamp).
- Restricts pulse currents to ground and hence limits leakage currents in the PE.
- Reduces the required EMI suppression efforts on the line side.
- Allows the use of lower rated drives with long motor cables due to lower losses in the IGBTs and in the motor cable.

Typical applications

- Motor drive applications with extremely long motor cables
- Motor drive applications with unshielded motor cables
- Chemical and petro-chemical applications
- Semi-conductor manufacturing
- Mission critical applications
- Applications with multiple motors in parallel
- Retrofit of motor drives into existing installations with old wiring and motors

Filter selection table

Filter	Rated current @ 40°C	Typical motor power rating*	Typical power loss**	Input connections	Output connections	Weight
	[A]	[kW]	[W]			[kg]
FN 530-4-99	4	1.5	15	-29	-99	11.5
FN 530-8-99	8	3.0	33	-29	-99	15
FN 530-12-99	12	5.5	50	-29	-99	18.5
FN 530-16-99	16	7.5	37	-33	-99	21

* General purpose four-pole (1500r/min) AC induction motor rated 400V/50Hz.

** Exact value depends upon the motor cable type and length, switching frequency, motor frequency and further stray parameters within the system.

Typical block schematic

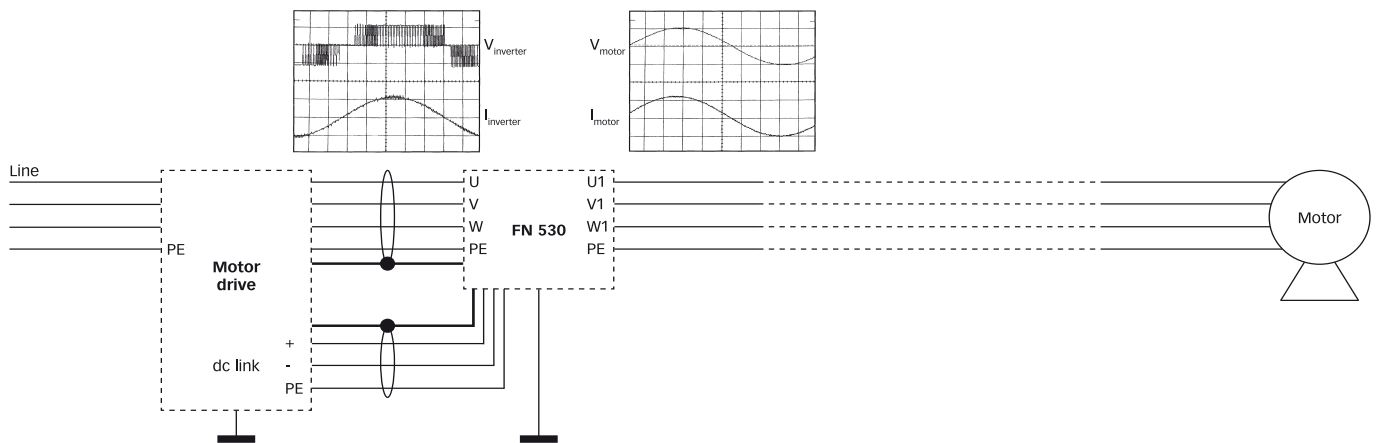

Connection to the dc link

For best results, the connection to the dc link of the motor drive is required with this series of filters.

If only one connection to the dc link is brought out of the drive («+» or «-») then the dc link cable connections from the filter (identified by «DC+» and «DC-») must be con-

nected together to the «+» or «-» motor drive connection.

The operation of the sine wave interference filter is not seriously affected as a result.

The «+» and «-» connections on the motor drive must never be connected together.

Otherwise a short-circuit will result.

The PWM switching frequency must lie within the range from 6 to 20kHz in order to ensure satisfactory operation of the filter. A lower switching frequency or a pure square wave is unsuitable and will result in the motor drive switching off with the error message «overcurrent or short to earth.»

For additional information please ask for FN 530 installation instructions and the Schaffner application note „Output Filters for Use with Frequency Inverters in Motor Drive Applications“.

Mechanical data

4 to 12A types

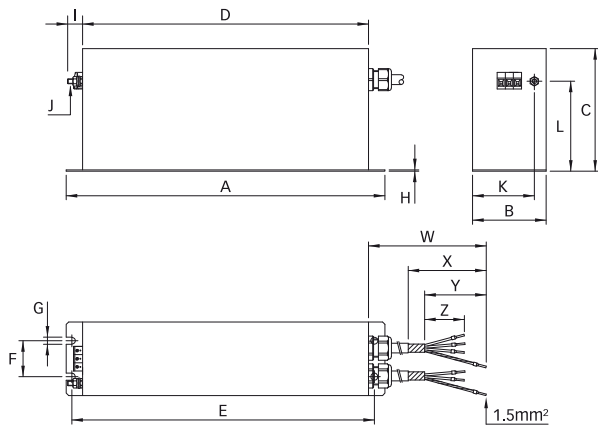

16A types

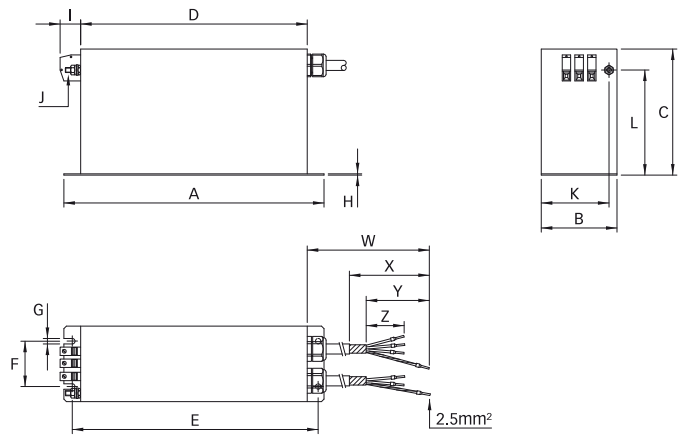

Dimensions

	4A	8A	12A	16A
A	390	390	390	350
B	90	90	90	140
C	150	180	215	230
D	350	350	350	310
E	373	370	370	330
F	44	44	44	95
G	6.5	8.7	8.7	8.7
H	1.5	1.5	1.5	2.3
I	19	19	19	25
J	M6	M6	M6	M6
K	75	75	75	107.5
L	107	137	172	181
W	720 +15/-0	720 +15/-0	720 +15/-0	720 +15/-0
X	120	120	120	120
Y	100	100	100	100
Z	70	70	70	70

All dimensions in mm; 1 inch = 25.4mm
Tolerances according: ISO 2768-m / EN 22768-m

Filter input connector cross sections

	-29	-33
Solid wire	6mm ²	16mm ²
Flex wire	4mm ²	10mm ²
AWG type wire	AWG 10	AWG 6
Recommended torque	0.6 - 0.8Nm	1.5 - 1.8Nm

Please visit www.schaffner.com to find more details on filter connectors.