

Electrical Testing  
per Tusonix standard  
test plans and Mil-Std-202  
Test Methods.

**MARKETING SALES DRAWING**  
**DIMENSIONS IN INCHES - DO NOT SCALE THIS DRAWING**  
**DIMENSIONS IN METRIC - [ ]**

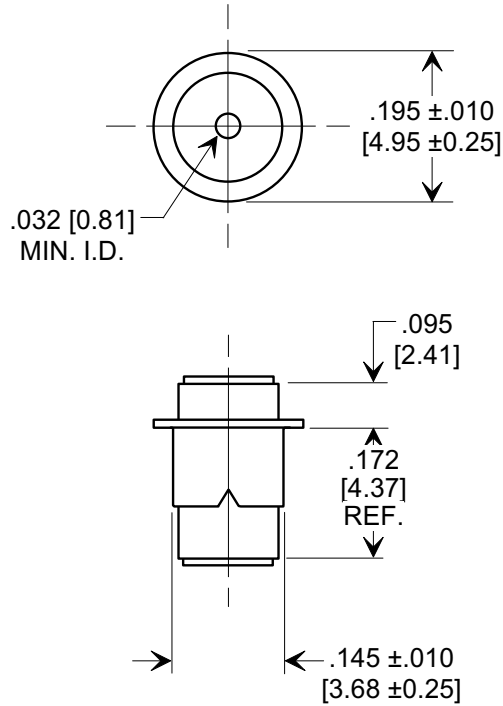
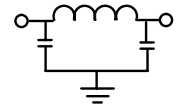
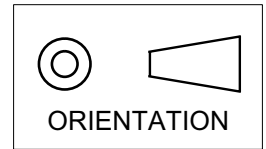

**NOTES:**

- TUSONIX STANDARD PART NUMBER: 4101-000.  
TUSONIX RoHS COMPLIANT PART NUMBER: 4101-000 LF.  
CUSTOMER MUST SPECIFY STANDARD OR RoHS PART NUMBER WHEN ORDERING.
- RoHS COMPLIANT PART MARKED WITH GREEN DOT FOR IDENTIFICATION.

MIN. CAP. (pF)	WORKING VOLTAGE (WVdc)		CURRENT Idc.	I.R. MIN. @ 100 (VDC.)	DWV (VDC)	MINIMUM NO LOAD INSERTION LOSS (dB) AT 25°C PER MIL-STD-220			
	85°C	125°C				10 MHz	100 MHz	1 GHz	10 GHz
1750	250	125	10 A	10 G	500	5	35	50	50

<b>X-2015 Rev-0</b>	<b>REVISION RECORD</b>				--TOLERANCES-- Unless Otherwise Specified		Title	
	0	Original Release C.O.			DECIMAL ± .015 [0.38]		<b>EYELET STYLE EMI FILTER</b> Drawn S.M. 07-19-00 Scale 4 X Approved T.C. 07-19-00	
	1	WAS SK 6644-080-S. LE 1-13-84			ANGLES ±			
	2	DIM'S & TOL'S REV'D. RELEASED. L.E. 1-8-85			<b>TUSONIX</b> TUCSON, ARIZONA		<b>A</b> <b>4101-000</b>	
	3	C.O.1653 CURRENT UNIT "A" ADDED L.E. 8-20-85						
	4	2595 RDN. TO COMP. FMT. S.M. 07-19-00						
5	20000914-3-03 DIM. .145 TOL WAS ±.018. ADDED IR, DWV & CIRCUIT. S.M.11-05-04							
6	20041105-1-01 ADDED NOTES. S.M. 03-14-05							
	20050314-3-01							