

MARKETING SALES DRAWING

DIMENSIONS IN INCHES - DO NOT SCALE THIS DRAWING
 DIMENSIONS IN METRIC []

Electrical Testing
 per Tusonix standard
 test plans and Mil-Std-202
 Test Methods.

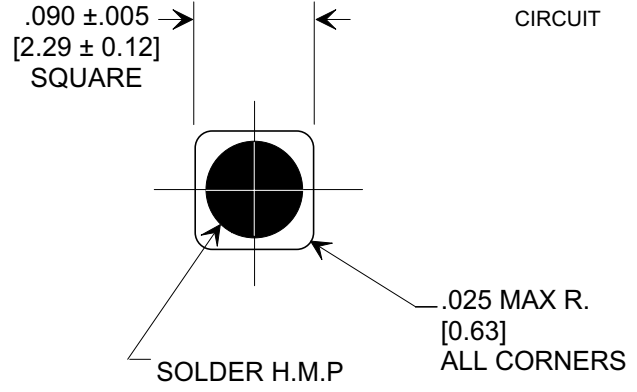
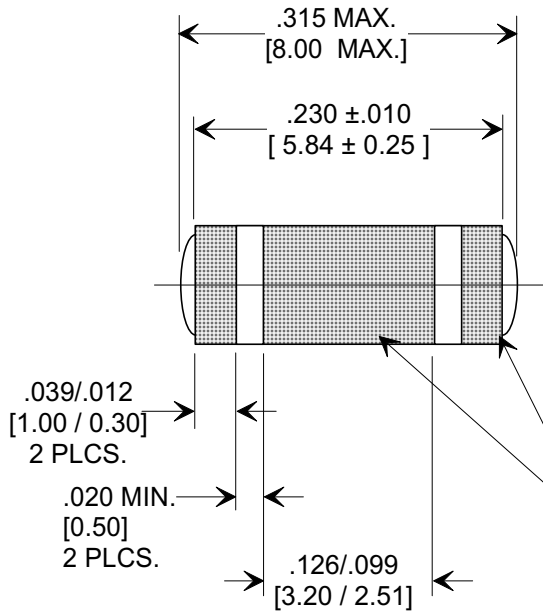
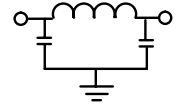
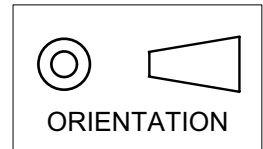

ELECTRODE
 TERMINATION
 SEE NOTE 5.

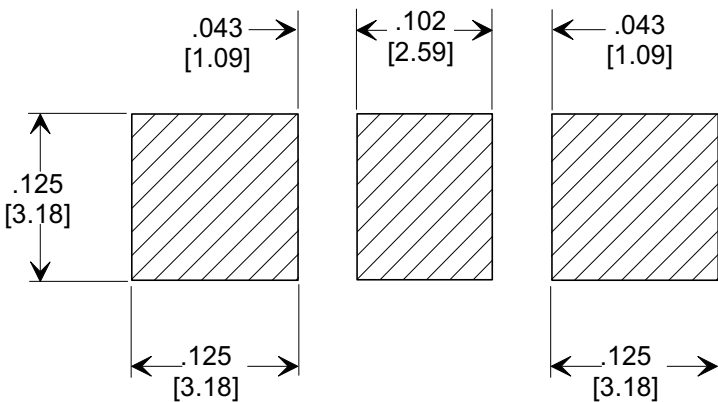

SUGGESTED
 MOUNTING PATTERN

1. INDUCTANCE TO BE 0.1 μH MINIMUM.
2. PACKAGE: BULK OR BLISTER TAPE TO IEC-60286-3 TYPE II AND EIA-481-A.
3. TUSONIX STANDARD PART NUMBER: 4700-009. TUSONIX RoHS COMPLIANT PART NUMBER: 4700-009 LF. CUSTOMER MUST SPECIFY STANDARD OR RoHS PART NUMBER WHEN ORDERING.
4. PART MARKING: STANDARD PART: NO MARKING. RoHS PART: LABELED ON PACKAGING ONLY.
5. ELECTRODE TERMINATION: STANDARD 60/40 SOLDER; RoHS COMPLIANT - MATTE TIN.

CAP.	TOLERANCE	VVDC		TEST VOLTAGE	I.R.MIN. @ 100 (VDC.)	I _{DC}	TYPICAL NO LOAD INSERTION LOSS dB AT 25°C PER MIL-STD-220		
		85°C	+125°C				10 MHZ	100 MHZ	1 GHZ
470 pF	+80% / -20%	100	100	300 VDC	10 G Ω	10 A	1	16	40

X-2015 Rev-0	REVISION RECORD	0		1	2	3
	Original Release	20020111-1-01		20030213-1-13	20030619-2-05	20050916-1-03
	REVISED DWG. I.R. MIN @ 100 (VDC) ADDED					
	S.M. 02-13-03					
	REVISED DWG. S.M. 06-20-03					
	REVISED NOTES. S.M. 09-19-05					

--TOLERANCES-- Unless Otherwise Specified		Title SURFACE MOUNT SQUARE STYLE PI FILTER	
DECIMAL ± .005 [0.13]	Drawn S.M. 01-14-02	Scale 7 X	
ANGLES ±	Approved B.Mc. 01-14-02		
TUSONIX TUCSON, ARIZONA		A	4700-009