

MARKETING SALES DRAWING

DIMENSIONS IN INCHES - DO NOT SCALE THIS DRAWING
 DIMENSIONS IN METRIC []

Electrical Testing
 per Tusonix standard
 test plans and Mil-Std-202
 Test Methods.

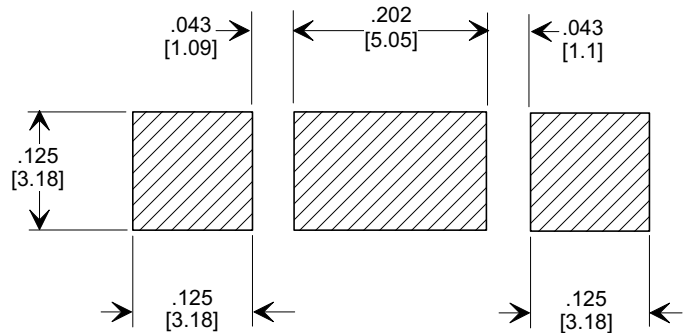
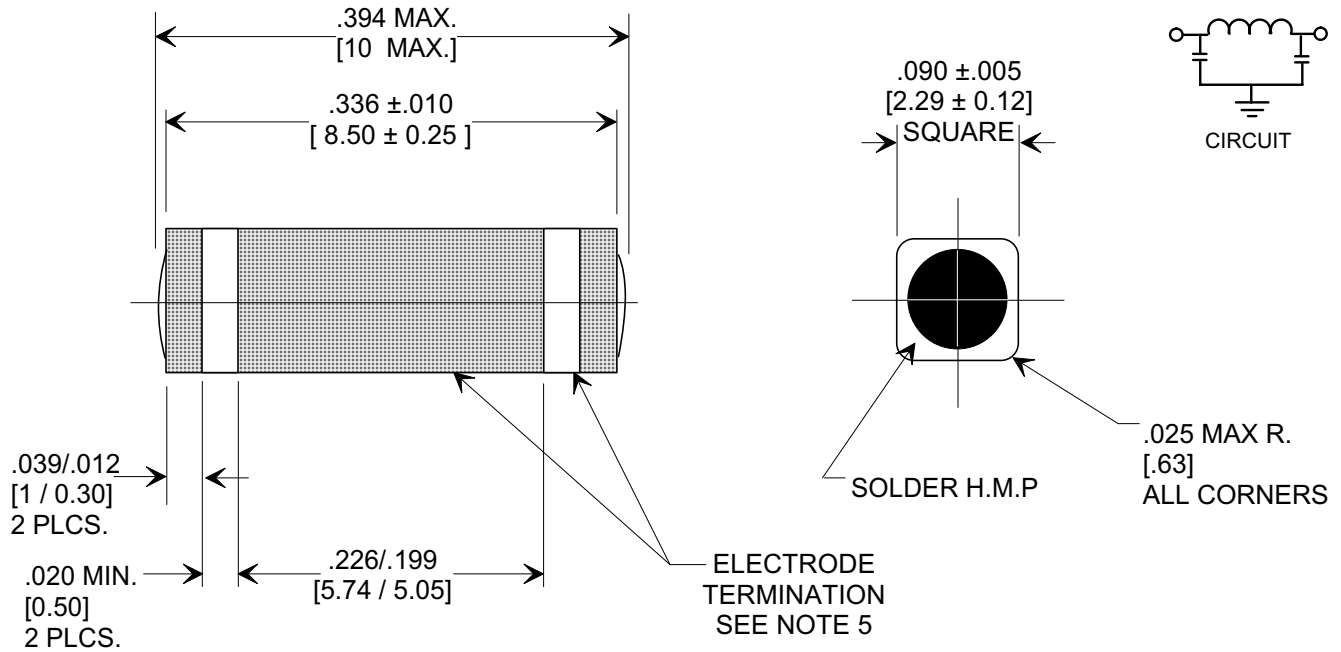
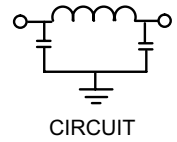
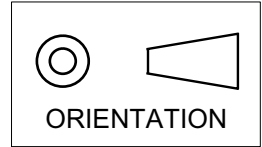

SUGGESTED MOUNTING PATTERN
 (SACLE 5 X)

NOTES:

1. INDUCTANCE TO BE 0.1 H MINIMUM.
2. PACKAGE: BULK OR BLISTER TAPE TO IEC-286-3 TYPE II AND EIA-481-A.
3. TUSONIX STANDARD PART NUMBER: 4701-001.
 TUSONIX RoHS COMPLIANT PART NUMBER: 4701-001 LF.
 CUSTOMER MUST SPECIFY STANDARD OR RoHS PART NUMBER WHEN ORDERING.
4. PART MARKING: STANDARD PART: NO MARKING. RoHS PART: LABELED ON PACKAGING ONLY.
5. ELECTRODE TERMINATION: 60/40 SOLDER: RoHS COMPLIANT: MATTE TIN.

CAP.	TOLERANCE	WVDC +85°C	TEST VOLTAGE	I.R.MIN. @ 100 (VDC.)	IDC	ELECTRODE TERMINATION	TYPICAL NO LOAD INSERTION LOSS dB AT 25°C PER MIL-STD-220		
							10 MHZ	100 MHZ	1 GHZ
8,200 pF	+80% / -20%	100	300 VDC	10 G	10 A	SOLDER	20	65	70

X-2015 Rev-0

REVISION RECORD	Original Release C.O. 950911-2	REVISION RECORD	Title SURFACE MOUNT SQUARE STYLE PI FILTER	
	0 DIM .090 WAS .085. REVISED MOUNTING PAT. S.M. 09-19-01			--TOLERANCES-- Unless Otherwise Specified
	6 REVISED DWG. DRAWING MADE FOR EACH VAR. S.M. 02-13-03			DECIMAL ± .005 [0.10]
	7 REVISED DRAWING. S.M. 06-23-03			ANGLES ±
8 ADDED NOTES 3,4 & 5. S.M. 06-23-05	TUSONIX TUCSON, ARIZONA	Drawn EC 08-11-95	Scale 7 X	
9 20050617-3-02		Approved NV 08-11-95	A	
			4701-001	