

## 3-terminal Filters(SMD) For Wide-band

Conformity to RoHS Directive

### MEM Series MEM2012TC Type

#### FEATURES

- Multilayer chip EMC filter utilizing a T-type circuit.
- Entirely monolithic structure results in high reliability.
- Due to closed magnetic circuit architecture, high-density installation becomes possible, and crosstalk generation is prevented.
- Steep attenuation characteristic plot. Highly effective noise suppression.
- Covers a wide range of frequencies.
- MEM2012TC combines a bead inductor with a through-type capacitor.

#### APPLICATIONS

Computer and computer peripherals, VCRs, TVs, car audio equipment, printers, game machines, etc.

#### TEMPERATURE RANGES

Operating/Storage	-40 to +85°C
-------------------	--------------

#### PRODUCT IDENTIFICATION

MEM	2012	T	C100	T
(1)	(2)	(3)	(4)	(5)

- (1)Series name  
 (2)Dimensions L×W  
 (3)T-type circuit  
 (4)Capacitance C100:10pF at 1MHz  
 (5)Packaging style T:Taping

#### PACKAGING STYLE AND QUANTITIES

Packaging style	Quantity
Taping	4000 pieces/reel

#### SHAPES AND DIMENSIONS/RECOMMENDED PC BOARD PATTERN

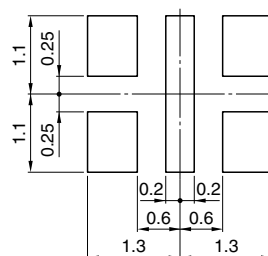
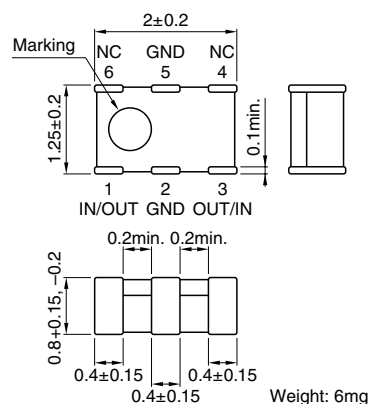

Dimensions in mm

#### ELECTRICAL CHARACTERISTICS

Part No.	Capacitance* (pF)	Tolerance (%)	Rated voltage Edc(V)max.	Rated current Idc(A)max.	DC resistance (Ω) max. [Terminal No.1 to 3]
MEM2012TC100	10	±30	12	1	0.12
MEM2012TC220	22	±30	12	1	0.12
MEM2012TC470	47	±30	12	1	0.12
MEM2012TC101	100	±30	12	1	0.12
MEM2012TC151	150	±30	12	1	0.12

\*Measuring frequency: 1(MHz), measuring voltage: 1(V)

- Conformity to RoHS Directive: This means that, in conformity with EU Directive 2002/95/EC, lead, cadmium, mercury, hexavalent chromium, and specific bromine-based flame retardants, PBB and PBDE, have not been used, except for exempted applications.
- Please contact our Sales office when your application are considered the following:  
The device's failure or malfunction may directly endanger human life (e.g. application for automobile/aircraft/medical/nuclear power devices, etc.)

• All specifications are subject to change without notice.

### TYPICAL ELECTRICAL CHARACTERISTICS ATTENUATION vs. FREQUENCY CHARACTERISTICS

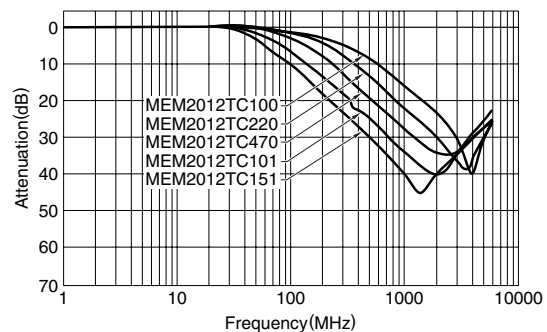

### MEASURING CIRCUIT

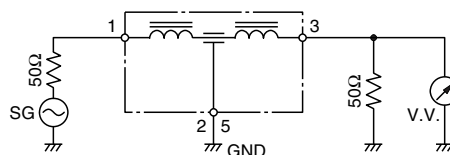

### RECOMMENDED SOLDERING CONDITION REFLOW SOLDERING

