

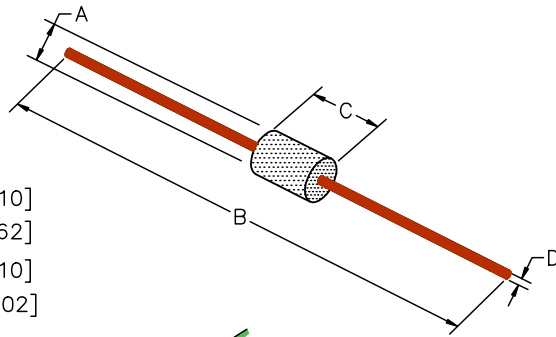

28L0138-50R-10



PHYSICAL DIMENSIONS:

A	3.51 [.138]	± 0.25 [.010]
B	59.00 [2.32]	± 1.57 [.062]
C	9.53 [.375]	± 0.25 [.010]
D	0.64 [.025]	± 0.05 [.002]

ELECTRICAL CHARACTERISTICS:				
	Z (Ω) @		DCR (Ω)	Rated Current
	25 MHz	100MHz		
Nominal	92	153		
Minimum	-	114		
Maximum	-	191	0.01	5,000 mA

UNCONTROLLED DOCUMENT



|Z| , R, AND X vs. FREQUENCY

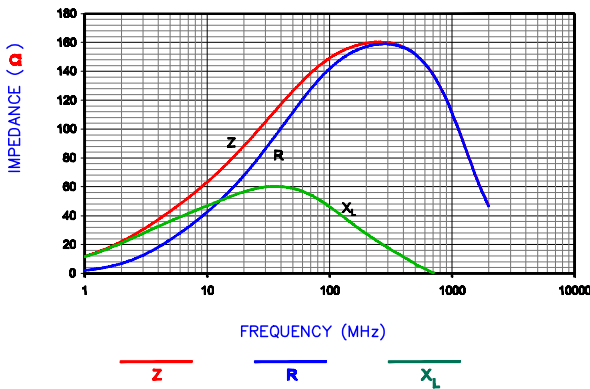

NOTES: UNLESS OTHERWISE SPECIFIED

1. TAPED AND REELED per CURRENT EIA SPECIFICATIONS 14" REELS, 4500 PCS/REEL.
2. COMPONENTS SHOULD BE ADEQUATELY PREHEATED BEFORE SOLDERING.
3. WIRE: C10200 OXYGEN FREE COPPER (99.95 MIN.) 22AWG (.025 DIA.)
4. PLATING: 100% TIN 5μ ± 2μ [200 μin ± 80μin]
5. WEIGHT/1000: .440 kgs. .970 lbs.
6. REFERENCE STEWARD CORE P/N 28B0138-*00.

HP 4396A Network/Spectrum Analyzer
HP 43961A Impedance Test Kit, HP 16192A Test Fixture

DIMENSIONS ARE IN mm (INCHES).				THIS DOCUMENT CONTAINS INFORMATION WHICH IS PROPRIETARY AND CONFIDENTIAL TO STEWARD. NO PRODUCTION OR PUBLICATION OF THIS DOCUMENT IN WHOLE OR IN PART SHALL BE MADE WITHOUT WRITTEN AUTHORIZATION FROM STEWARD.			
G	ADD ROHS SYMBOL UPDATE LOGO	04/20/07	JRK				
F	CHANGE P/N (ADD -10) CHG NOTE 3 ADD NO LEAD SYMBOL, COR. PART WGT	10/14/03	JRK				
E	UPDATE PRINT FORMAT REM SHEET 40F4 ADDED NOTES TO SHEET 20F3.	10/22/01	JRK				
D	ADDED (*NOTE&DIM) TO SHT 30F4 CORRECTED DIM D ON SHT 2 OF 4	10/12/98	DTR	PROJECT/PART NUMBER:	REV	PART TYPE:	DRAWN BY:
C	UPDATE PRINT FORMAT	08/06/98	DTR	28L0138-50R-10	G	ASSEMBLY	BENTON
B	UPDATE DIM C	12/18/96	GEM	DATE:	SCALE:	NTS	SHEET:
REV	DESCRIPTION	DATE	INT	06/21/90	B0138		2 of 3