

29F0818-1SR-10

UNCONTROLLED DOCUMENT

PHYSICAL DIMENSIONS:

A	11.43 [.450]	+ 0.18 [.007]	
B	4.50 [.177]	+ 0.08 [.003]	- 0.10 [.004]
B1	7.04 [.277]	+ MAX	
C	4.19 [.165]	+ 0.10 [.004]	
C1	4.83 [.190]	+ MAX	
D	2.24 [.088]	+ 0.08 [.003]	
E	1.27 [.050]	+ 0.13 [.005]	

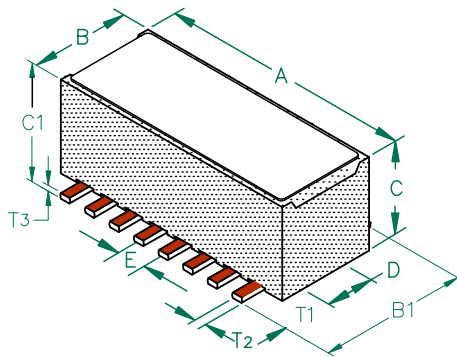

PHYSICAL DIMENSIONS:

T1	2.16 [.085]	+ 0.25 [.010]	
T2	0.50 [.020]	+ TYP.	
T3	0.25 [.010]	+ TYP.	

ELECTRICAL CHARACTERISTICS:			
Z @ 100MHz (Ω)	DCR (Ω)	Rated Current	
Nominal	119		
Minimum	90		
Maximum	149	0.01	6,000 mA

- NOTES: UNLESS OTHERWISE SPECIFIED
1. TAPED AND REELED per CURRENT EIA SPECIFICATIONS 13" REELS, 900 PCS/REEL.
 2. COMPONENTS SHOULD BE ADEQUATELY PREHEATED BEFORE SOLDERING.
 3. REF. CARRIER TAPE SPECIFICATION # CART 818-13.
 4. TERMINATION FINISH IS 100% TIN.



|Z|, R, AND X vs. FREQUENCY

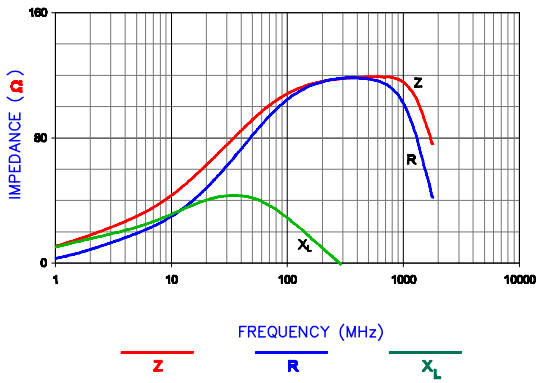

LAND PATTERNS FOR REFLOW SOLDERING

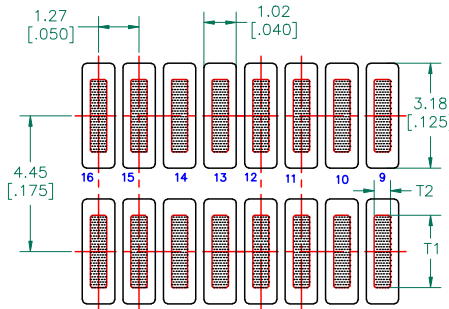

RECOMMENDED SOLDERING CONDITIONS

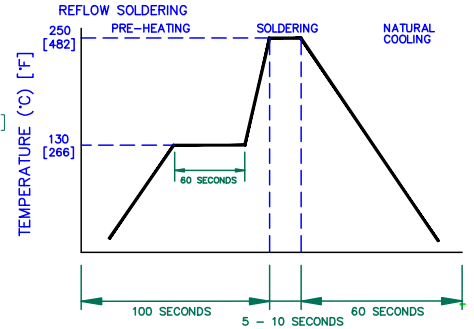

DIMENSIONS ARE IN mm [INCHES]

E		UPDATE COMPANY LOGO	10/22/08	JRK	This print is the property of Laird Tech. and is loaned in confidence subject to return upon request and with the understanding that no copies shall be made without the written consent of Laird Tech. All rights to design or invention are reserved.	
D		UPDATE COMPANY LOGO	05/04/07	JRK		
C		CHG TOLS ON E DIMS CORRECT T2 DIMS IN LANDPATTERN	03/21/07	JRK	PROJECT/PART NUMBER:	REV: E
B		COR REV BLOCK mm [INCHES] ADD ROHS	10/19/06	JRK	29F0818-1SR-10	
A		ORIGINAL DRAFT	04/30/04	JRK	DATE: 04/30/04	SCALE: NTS
REV		DESCRIPTION	DATE	INT	CAD: 29F0818-1SR-10-E-2	TOL # H0818
						DRAWN BY: JRK
						SHEET: 2 of 3

HP 4396A Network/Spectrum Analyzer
HP 43961A Impedance Test Kit, HP 16192A Test Fixture

