

# 28L0138-70R-10

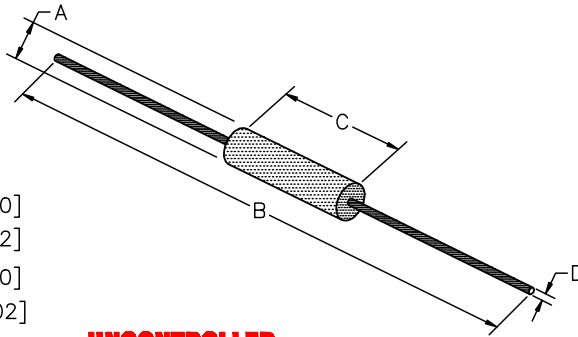

ELECTRICAL CHARACTERISTICS:				
	Z ( $\Omega$ ) @		DCR ( $\Omega$ )	Rated Current
	25 MHz	100MHz		
Nominal	123	220		
Minimum	-	165		
Maximum	-	275	0.01	5,000 mA

## PHYSICAL DIMENSIONS:

A	3.51 [.138]	$\pm$ 0.25 [.010]
B	59.00 [2.32]	$\pm$ 1.57 [.062]
C	13.97 [.550]	$\pm$ 0.51 [.020]
D	0.64 [.025]	$\pm$ 0.05 [.002]

**UNCONTROLLED DOCUMENT**



|Z| , R, AND X vs. FREQUENCY

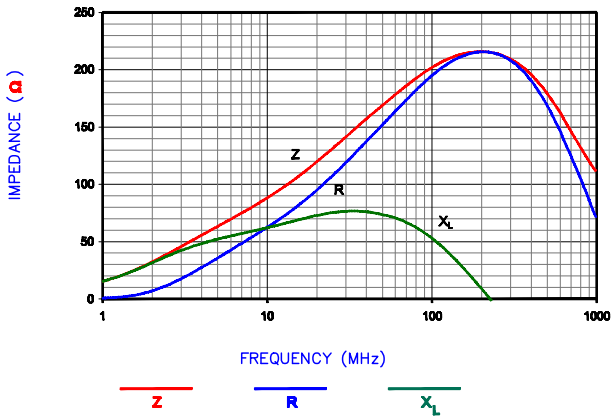

NOTES: UNLESS OTHERWISE SPECIFIED

1. TAPED AND REELED per CURRENT EIA SPECIFICATIONS 14" REELS, 4500 PCS/REEL.
2. COMPONENTS SHOULD BE ADEQUATELY PREHEATED BEFORE SOLDERING.
3. WIRE: C10200 OXYGEN FREE COPPER (99.95 MIN.) 22AWG (.025 DIA.)
4. PLATING: 100% TIN  $5\mu \pm 2\mu$  [200  $\mu\text{in} \pm 80\mu\text{in}$ ]
5. WEIGHT/1000: .667 kgs 1.47 lbs.
6. REFERENCE STEWARD CORE P/N 28B0138-\*00.

HP 4396A Network/Spectrum Analyzer  
HP 43961A Impedance Test Kit, HP 16192A Test Fixture

DIMENSIONS ARE IN mm (INCHES).				THIS DOCUMENT CONTAINS INFORMATION WHICH IS PROPRIETARY AND CONFIDENTIAL TO STEWARD. NO PRODUCTION OR PUBLICATION OF THIS DOCUMENT IN WHOLE OR IN PART SHALL BE MADE WITHOUT WRITTEN AUTHORIZATION FROM STEWARD.			
G	ADD ROHS SYMBOL UPDATE COMPANY LOGO	04/23/07	JRK				
F	CHG P/N TO-10, REV NOTE 3, CORRECT WGT	10/16/03	JRK				
E	UPDATE PRINT FORMAT REM SHEET 40F4 ADDED NOTES TO SHEET 20F3.	10/10/01	JRK				
D	ADDED (*NOTE&DIM) TO SHT 30F4 CORRECTED DIM D ON SHT 2 OF 4	10/13/98	DTR				
C	UPDATE PRINT FORMAT	06/30/98	DTR				
B	MATCH REV LEVEL ON 4 OF 4	06/30/98	DTR	PROJECT/PART NUMBER:	REV	PART TYPE:	DRAWN BY:
A	ORIGINAL DRAFT	06/30/98	DTR	28L0138-70R-10	G	ASSEMBLY	DTR
REV	DESCRIPTION	DATE	INT	DATE:	SCALE:	SHEET:	
				06/30/98	NTS	2 of 3	
				28L0138-70R-10-2-G	TOOL #		
					B0138		