

28L0138-40R-10

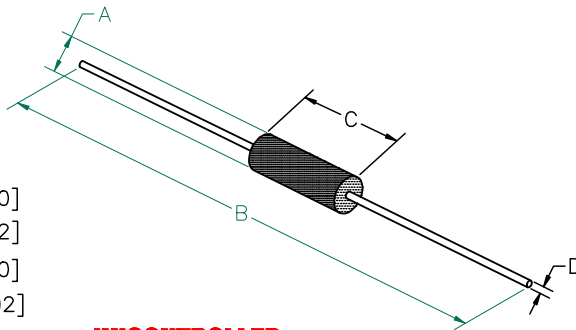

ELECTRICAL CHARACTERISTICS:				
	Z (Ω) @		DCR (Ω)	Rated Current
	25 MHz	100MHz		
Nominal	99	135		
Minimum	-	101		
Maximum	-	169	0.01	5,000 mA

PHYSICAL DIMENSIONS:

A	3.51 [.138]	\pm 0.25 [.010]
B	59.00 [2.32]	\pm 1.57 [.062]
C	8.89 [.350]	\pm 0.51 [.020]
D	0.64 [.025]	\pm 0.05 [.002]

UNCONTROLLED DOCUMENT



|Z|, R, AND X vs. FREQUENCY

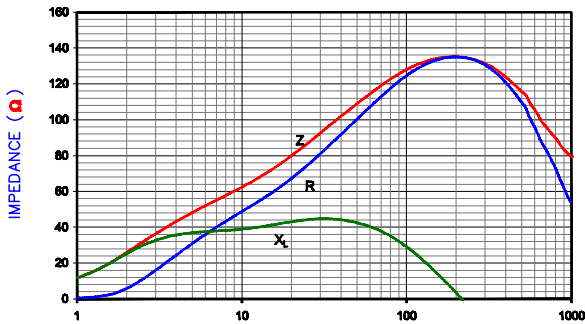

FREQUENCY (MHz)

Z R X_L

AGILENT E4991A RF Impedance/Material Analyzer
HP 16194A Test Fixture

NOTES: UNLESS OTHERWISE SPECIFIED

- TAPED AND REELED per CURRENT EIA SPECIFICATIONS 14" REELS, 4500 PCS/REEL.
- COMPONENTS SHOULD BE ADEQUATELY PREHEATED BEFORE SOLDERING.
- WIRE: C10200 OXYGEN FREE COPPER (99.95 MIN.) 22AWG (.025 DIA.)
- PLATING: 100% TIN $5\mu \pm 2\mu$ [$200\mu\text{in} \pm 80\mu\text{in}$]
- WEIGHT/1000: .411 kgs. .905 lbs.
- REFERENCE STEWARD CORE P/N 28B0138-*00.

DIMENSIONS ARE IN mm (INCHES).				THIS DOCUMENT CONTAINS INFORMATION WHICH IS PROPRIETARY AND CONFIDENTIAL TO STEWARD. NO PRODUCTION OR PUBLICATION OF THIS DOCUMENT IN WHOLE OR IN PART SHALL BE MADE WITHOUT WRITTEN AUTHORIZATION FROM STEWARD.			
H	ADD ROHS SYMB. UPDATE COMPANY LOGO	04/20/07	JRK				
G	CHANGE P/N (ADD -10) CHG NOTE 3 ADD NO LEAD SYMBOL, CORRECT WGT.	10/14/03	JRK				
F	UPDATE FORMAT, CHG RATED CURRENT FROM 10,000 ADDED NOTES	10/11/01	JRK				
E	ADDED (*NOTE&DIM) ON SHT30F4 CORRECTED DIM D ON SHEET 20F4	10/13/98	DTR				
D	SEE PAGE 30F4 FOR CHGS	07/15/98	DTR	PROJECT/PART NUMBER: 28L0138-40R-10	REV H	PART TYPE: ASSEMBLY	DRAWN BY: DTR
C	UPDATE PRINT FORMAT	06/25/98	DTR	DATE: 06/30/98	SCALE: NTS	SHEET: B0138	
REV	DESCRIPTION	DATE	INT	DATE: 28L0138-40R-10-2-H	TOOL #: B0138	SHEET: 2 of 3	