

AC feedthrough capacitor



- IEC/EN 60384-14 approval
- Rated currents from 10 to 200A
- 5kV pulse test capability
- Class Y2 capacitor

Approvals



Technical specifications

Maximum continuous operating voltage:	250VAC, 50/60Hz (UL) 300VAC, 50/60Hz (ENEC) 1000VDC max.
Rated currents:	10 to 200A @ 60°C max.
Capacitor class:	Y2
High potential test voltage:	3000VDC for 2 sec
Insulation resistance (100VDC after 60 sec):	< 0.33μF, R > 1500MΩ > 0.33μF, τ > 5000s
Temperature range (operation and storage):	-40°C to +100°C (40/100/21)
Flammability corresponding to:	UL 94V-2 or better
MTBF @ 60°C/300V (Mil-HB-217F):	< 200A: > 1,600,000 hours ≥ 200A: > 850,000 hours

Typical electrical schematic

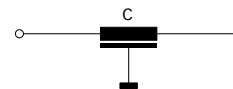

Feedthrough capacitors offer a high insertion loss across a broad band of frequencies from a few tens of kHz up to the GHz region. The construction of feedthrough capacitors cause a better suppression performance over a much wider frequency range than a conventional two-wire capacitor of equivalent value. Different versions are available offering a wide selection on operating currents and performance levels. AC feedthrough capacitors are designed and approved for up to 300VAC 50/60Hz operation.

Features and benefits

- Very low internal series inductance.
- Very high self-resonant frequency.
- Self-healing dielectric.
- High quality and reliability.
- Through-bulkhead mounting.
- Anti-twist protection.
- Custom-specific or dual-versions on request.

Typical applications

- Power line filter for 110/240VAC power lines
- Increasing system and information security
- Power supplies
- Switching and cellular equipment
- Computer servers
- UPS power supplies
- Medical equipment
- Shielded rooms

Feedthrough selector table

Feedthrough	Rated current	Leakage current*	Capacitance**	DC resistance***	Weight
	@ 60°C	@ 250VAC/50Hz	C	R @ 25°C	
	[A]	[mA]	[nF]	[mΩ]	[g]
FN 7510-10-M3	10	0.21	2.2	0.8	15
FN 7511-10-M3	10	0.44	4.7	0.8	15
FN 7510-16-M4	16	0.44	4.7	0.5	28
FN 7511-16-M4	16	0.94	10	0.52	28
FN 7512-16-M4	16	4.4	47	0.62	33
FN 7513-16-M4	16	9.4	100	0.58	65
FN 7510-20-M4	20	0.44	4.7	0.5	28
FN 7510-32-M4	32	0.44	4.7	0.52	28
FN 7511-32-M4	32	0.94	10	0.52	28
FN 7512-32-M4	32	3.1	33	0.62	34
FN 7514-32-M4	32	9.4	100	0.58	65
FN 7512-63-M6	63	9.4	100	0.3	70
FN 7510-100-M8	100	4.4	47	0.23	100
FN 7511-100-M8	100	9.4	100	0.23	100
FN 7511-200-M10	200	20.7	220	0.16	157

* Tolerance +20%
 ** Tolerance ±20%
 *** Tolerance +15%

Typical filter attenuation

50Ω system

10A types

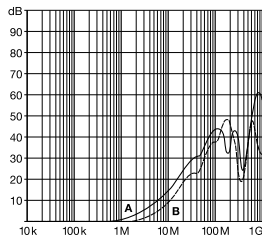

A = FN 7511-10-M3
 B = FN 7510-10-M3

16 and 20A types

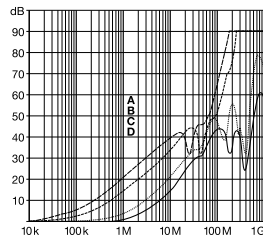

A = FN 7513-16-M4
 B = FN 7512-16-M4
 C = FN 7511-16-M4
 D = FN 7510-16-M4
 FN 7510-20-M4

32A types

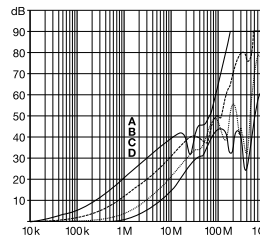

A = FN 7514-32-M4
 B = FN 7512-32-M4
 C = FN 7511-32-M4
 D = FN 7510-32-M4

63A types

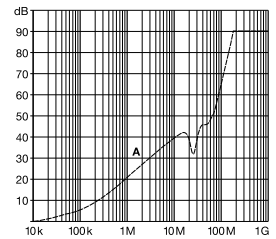

A = FN 7512-63-M6

100A types

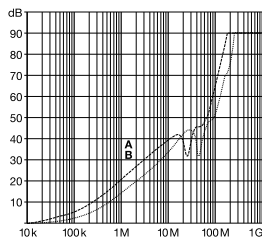

A = FN 7511-100-M8
 B = FN 7510-100-M8

200A types

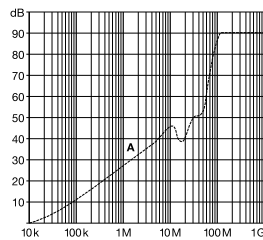

A = FN 7511-200-M10

Mechanical data

Panel cut out

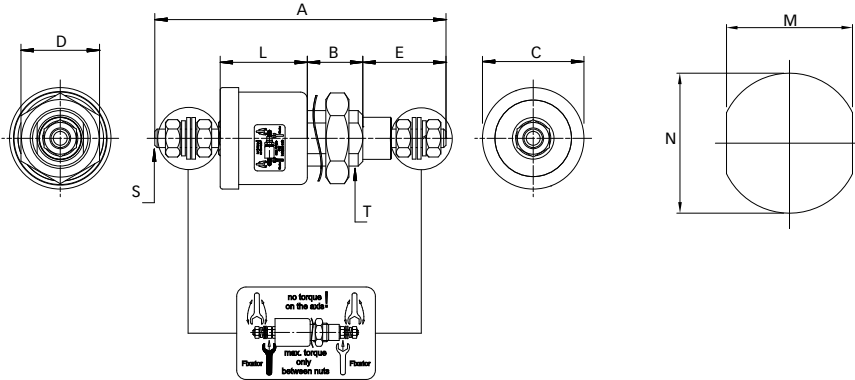

Dimensions

	A	B	C	D	E	L	M	N	S	T
FN 7510-10-M3	57	10	16.85 ±0.3	13	16 ±2.0	19.85 ±0.5	9.1	Ø10.3	M3	M10x1
FN 7511-10-M3	57	10	16.85 ±0.3	13	16 ±2.0	19.85 ±0.5	9.1	Ø10.3	M3	M10x1
FN 7510-16-M4	63	12	21.95 ±0.3	17	18 ±2.0	18.85 ±0.5	10.3	Ø12.3	M4	M12x1
FN 7511-16-M4	63	12	21.95 ±0.3	17	18 ±2.0	18.85 ±0.5	10.3	Ø12.3	M4	M12x1
FN 7512-16-M4	75	12	21.95 ±0.3	17	18 ±2.0	30.85 ±0.5	10.3	Ø12.3	M4	M12x1
FN 7513-16-M4	77	14	26.95	22	18 ±2.0	30.85 ±0.5	14.3	Ø16.3	M4	M16x1
FN 7510-20-M4	63	12	21.95 ±0.3	17	18 ±2.0	18.85 ±0.5	10.3	Ø12.3	M4	M12x1
FN 7510-32-M4	63	12	21.95 ±0.3	17	18 ±2.0	18.85 ±0.5	10.3	Ø12.3	M4	M12x1
FN 7511-32-M4	63	12	21.95 ±0.3	17	18 ±2.0	18.85 ±0.5	10.3	Ø12.3	M4	M12x1
FN 7512-32-M4	75	12	21.95 ±0.3	17	18 ±2.0	30.85 ±0.5	10.3	Ø12.3	M4	M12x1
FN 7514-32-M4	77	14	26.95 ±0.3	22	18 ±2.0	30.85 ±0.5	14.3	Ø16.3	M4	M16x1
FN 7512-63-M6	96	14	25	22	26 ±2.0	30	14.3	Ø16.3	M6	M16x1
FN 7510-100-M8	113	16	32	27	32 ±2.0	33	18.3	Ø20.3	M8	M20x1
FN 7511-100-M8	113	16	32	27	32 ±2.0	33	18.3	Ø20.3	M8	M20x1
FN 7511-200-M10	130	19	38	27	40 ±2.0	33	22.3	Ø24.3	M10	M24x1
Tolerances					±2		±0.2			

All dimensions in mm; 1 inch = 25.4mm
 Tolerances according: ISO 2768-m / EN 22768-m

Recommended torque

	M3	M4	M6	M8	M10	M10x1	M12x1	M16x1	M20x1	M24x1
Terminal thread	0.5Nm	1.2Nm	2.5Nm	5Nm	8Nm					
Mounting thread						2Nm	3Nm	4Nm	7Nm	8Nm