

**MARKETING SALES DRAWING**  
**DIMENSIONS IN INCHES - DO NOT SCALE THIS DRAWING**  
**DIMENSIONS IN METRIC - [ ]**

This drawing is the property of Tusonix, Inc., and may not be used, reproduced, published or disclosed to others without expressed authorization by Tusonix Inc.

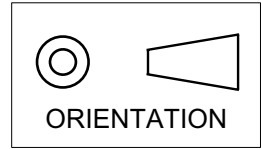

**Electrical Testing**  
per Tusonix standard  
test plans and Mil-Std-202  
Test Methods.

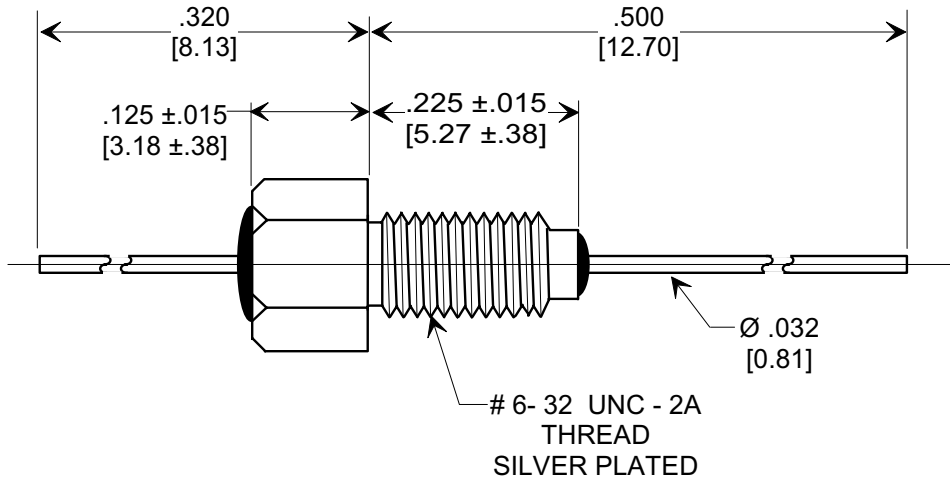
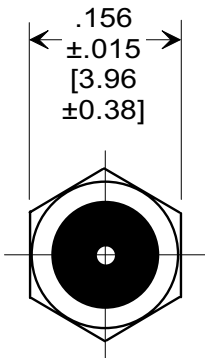
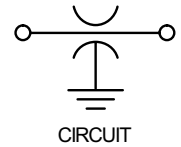

**MOUNTING HARDWARE**

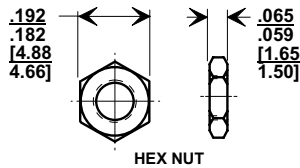
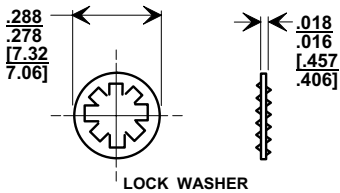

**NOTES:**

1. TUSONIX STANDARD PART NUMBER: 4402-018.  
TUSONIX RoHS COMPLIANT PART NUMBER: 4402-018 LF.  
CUSTOMER MUST SPECIFY STANDARD OR RoHS PART NUMBER WHEN ORDERING.
2. BUSHING: SILVER PLATED.
3. LEAD FINISH: STANDARD PART #: SOLDER PLATED. RoHS PART #: SILVER PLATED.
4. PART MARKING: TRADEMARK AND VARIATION NUMBER ON HEX FLATS. STANDARD PART: BLACK INK. RoHS PART: GREEN INK.
5. OPERATING TEMPERATURE RANGE: -55°C TO +125°C.
6. MAX. RECOMMENDED MOUNTING TORQUE: 2.0 lb.-in. [0.23 Nm].
7. MAX. RECOMMENDED SOLDERING TEMPERATURE: 260°C. SEE INSTALLATION RECOMMENDATIONS.
8. SILVER PLATED NUT AND LOCK WASHER INCLUDED.

MIN. CAP.(pf)	DC WORKING VOLTAGE	DC CURRENT (AMPS)	I.R. MIN. @ 100 (VDC)	DWV (VDC)	MINIMUM NO LOAD INSERTION LOSS (dB) AT 25°C PER MIL-STD-220						
	125 °C				1 MHz	3 MHz	10 MHz	30 MHz	100 MHz	300 MHz	1GHz
100,000	50	10A	10 G Ω	200	22	31	40	44	47	55	65

<b>REVISION RECORD</b> Original Release C.O. <b>941006-1</b> ADDED & REVISED NOTES. ADDED IR & DWV.S.M. 03-23-06 <b>20060310-3-10</b>	<b>0</b>	<b>--TOLERANCES--</b> Unless Otherwise Specified DECIMAL ± .031 [0.79] ANGLES ±	Title <b>BUSHING STYLE EMI FILTER</b>		
	<b>941006-1</b>		Drawn <b>S.M. 10-17-94</b>	Scale <b>X 5</b>	
	<b>20060310-3-10</b>	<b>TUSONIX</b> TUCSON, ARIZONA	Approved <b>B.Mc. 10-17-94</b>	<b>A</b>	<b>4402-018</b>

X-2015 Rev-0