

MARKETING SALES DRAWING
 DIMENSIONS IN INCHES - DO NOT SCALE THIS DRAWING
 DIMENSIONS IN METRIC - []

Electrical Testing
 per Tusonix standard
 test plans and Mil-Std-202
 Test Methods.

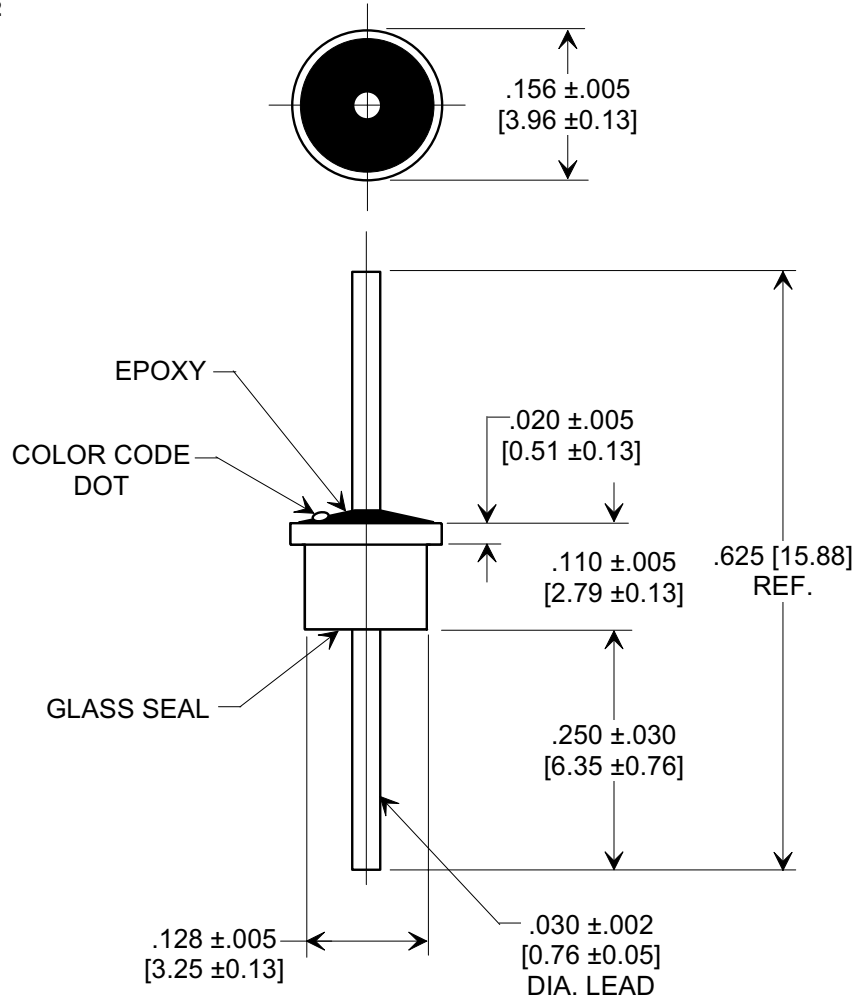

NOTES:

1. Operating temperature range: -55°C to +125°C.
2. Gold plated case and lead.
3. Epoxy sealed on opposite end from glass seal.
4. Max. recommended soldering temperature: 260°C.
See installation recommendations.
5. Recommended mounting hole: .135 dia.
6. Solder preform available for mounting.
7. Tusonix Standard part number: 4300-000.
Tusonix RoHS compliant part number: 4300-000 LF.
Customer must specify Standard or RoHS part number when ordering.
8. RoHS compliant part marked with additional dark green dot for identification.

Cx (pF)	TOL.	DC WORKING VOLTAGE		I.R. MIN. @ 100 (VDC.)	DWV (VDC)	DC CURRENT (AMPS)	MIN. NO LOAD INSERTION LOSS (dB) @ 25° C PER MIL-STD-220					COLOR CODE
		85°C	125°C				1 MHz	10 MHz	100 MHz	1GHz	10 GHz	
100	GMV	300	200	10 G	500	5	---	----	3	20	28	GREEN

X-2015 Rev-0

REVISION RECORD	Original Release	0	REDRAWN & REVISED ADDED 008, 009 & 010. E.C. 05-30-90 VARS 005, 006, 007 & 1MHz COLUMN ADDED. L.E. 11-07-90 VARS 080 WAS 010 & VAR 013 ADDED. L.E. 06-10-91 5966 RDN TO COMP FMP. STYLE DWG SPLIT FOR EACH VAR. S.M. 10-02-02 20021001-7-01 ADDED NOTES 7 & 8. S.M. 02-18-05 20050218-2-01 NOTES 7 & 8 REVISED. S.M. 05-23-05 20050511-2-06	--TOLERANCES-- Unless Otherwise Specified					Title SOLDER MOUNT EMI FILTER			
		10		DECIMAL ± NOTED					Drawn	S.M. 10-02-02	Scale	5 X
		11		ANGLES ±					Approved	T.C. 10-02-02		
		12		TUSONIX TUCSON, ARIZONA					A	4300-000		