

Magnetically Compensated Choke, 1-phase, high design



Description

- Current compensated choke
- 1-phase choke
- THT-terminals
- Inductor vertically positioned in housing

Standards

- EN 60938

Applications

- Attenuation of common mode interferences
- Designed for 230/400 VAC applications
- Chopper amplifiers
- DC drives and stepper motor controls
- Switching power supplies

References

Weblinks

[General Product Information](#), [Approvals](#), [RoHS](#), [CHINA-RoHS](#), [e-Store](#), [SCHURTER-Stock-Check](#), [Distributor-Stock-Check](#)

Technical Data

Rated voltage	up to 440 VAC
Rated Current	0.6 - 6 A @ Ta 40 °C
Rated inductance	0.6 - 50 mH, Tol. -30% +50%
Power Operating Frequency	50 - 400 Hz
Terminal technic	THT
Weight	3 - 30 g
Material: Housing	UL 94V-0
Sealing Compound	UL 94V-0

Test Voltage	1.8kV, 50Hz, 1 min, winding to winding
Isolation Voltage	2kV eff., winding to ambient
Climatic Category	25/100/21 acc. to IEC 60068-1
Allowable Operation Temp.	-25 °C to 100 °C

Dimensions

Case 50-2, 51-2, 52-2

Case 09-2

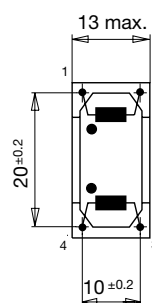
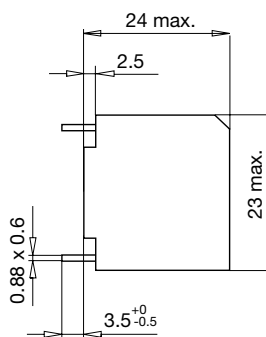
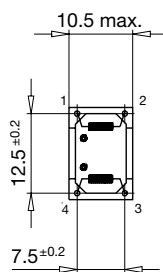
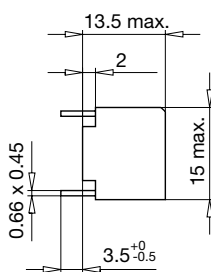

Case 19-2

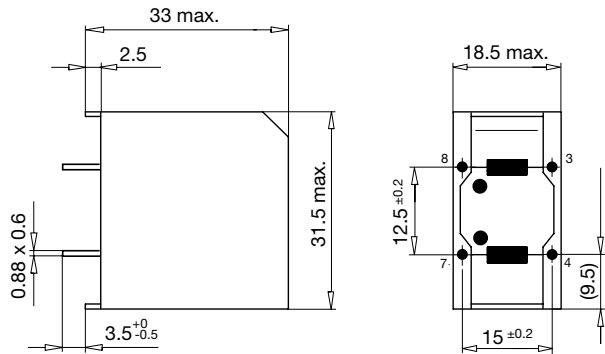

Variants

I_n [A]	L_n [mH]	R_{cu} [mΩ]	Tripped Power Dissipation [W]	f_{RES} [MHz]	Weight [g]	Housing	Packing unit [pcs.]	Order Number
0.6	11	600	0.5	0.5	3	50-2	100	DFKH-14-0001
0.6	50	1200	0.9	0.15	22	19-2	70	DFKH-31-0001
1	20	500	1	0.25	10	09-2	50	DFKH-22-0002
1	33	700	1.4	0.25	30	19-2	70	DFKH-31-0002
1	4	250	0.5	1.2	3	51-2	100	DFKH-14-0002
1.4	27	470	1.8	0.3	30	19-2	70	DFKH-31-0003
2	1	65	0.5	2.5	3	52-2	100	DFKH-14-0003
2	6	150	1.3	0.6	10	09-2	50	DFKH-22-0003
2	6.8	150	1.2	0.5	30	19-2	70	DFKH-31-0005
2.5	5.6	110	-	-	30	19-2	70	DFKH-31-0006
4	1.5	36	1.2	1.5	10	09-2	50	DFKH-22-0004
4	3.3	58	1.8	0.8	30	19-2	70	DFKH-31-0007
6	0.6	15	1.4	2.5	10	09-2	50	DFKH-22-0005
6	2	24	1.8	1.2	30	19-2	70	DFKH-31-0008