

Common Mode Choke Coils(Line Filters) for AC Power Supply

Compact and Separable Bobbin Type UF Series

Conformity to RoHS Directive

TDK common mode choke coils(line filters) are used in a wide range of prevention of electromagnetic interference(EMI) and radio frequency interference(RFI) from power supply lines and for prevention of multifunctioning of products such as measuring equipment and system equipment.

FEATURES

- Wide range of selection.
- High impedance at applicable frequency.
- High self-resonant frequency.

PRODUCT IDENTIFICATION

UF □□□□ V - A □□□Y □R□ - 01
 (1) (2) (3) (4) (5) (6) (7)

- (1) Core shape
UF: U-type core
- (2) Dimensional code
Length×Height
- (3) External shape code
V: Vertical type H: Horizontal type
- (4) High μ material
- (5) Inductance value
Example) 133:13mH
- (6) Rated current value
Example) 3R0:3.0A
- (7) Product management number

SELECTION CHART

Series	Configuration	Type	Inductance value min.	Rated current (A)	Handling power* $L \times I^2$ (mH×A ²)	Weight (g)typ.	Minimum package quantity (pieces/box)
UF	Two sections bobbin types	UF1717V	0.2 to 10mH	0.25 to 1.6	0.6	3.5	640
		UF1717H	0.2 to 10mH	0.25 to 1.6	0.6	3.5	480
	Two sections bobbin types (For high frequency)	UF1717V	10 to 60 μ H	1 to 3	0.08	3	640
		UF1815SG	50 to 350 μ H	1 to 5	1.2	4.6	1280

* Handling power=(Inductance value)×(Current)². It is possible to design within the range below this value.
 [Example] The coil for 2A can make even the inductance of 2.5mH or less a product for handling power 10.

- Conformity to RoHS Directive: This means that, in conformity with EU Directive 2002/95/EC, lead, cadmium, mercury, hexavalent chromium, and specific bromine-based flame retardants, PBB and PBDE, have not been used, except for exempted applications.

• All specifications are subject to change without notice.

Two Sections Bobbin Type UF Series

FEATURES

- This series is compact in size due to its use of high permeability ferrite core.

UF1717V/UF1717H(2 SEPARABLE BOBBIN) TYPES

SHAPES AND DIMENSIONS/CIRCUIT DIAGRAM

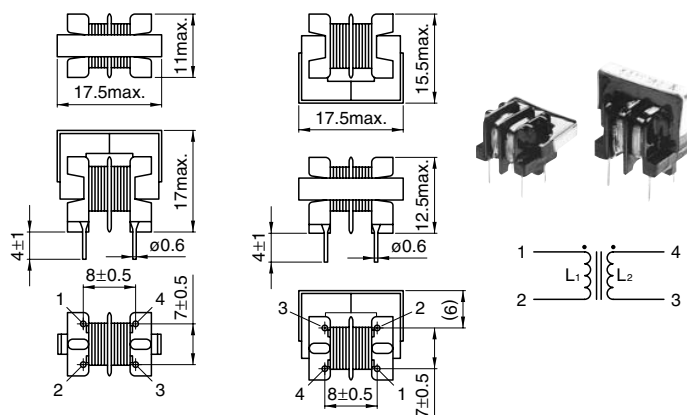

Weight: 3.5g typ.

Recommended hole diameter: $\phi 1.1$
Dimensions in mm

TYPICAL ELECTRICAL CHARACTERISTICS

IMPEDANCE vs. FREQUENCY CHARACTERISTICS

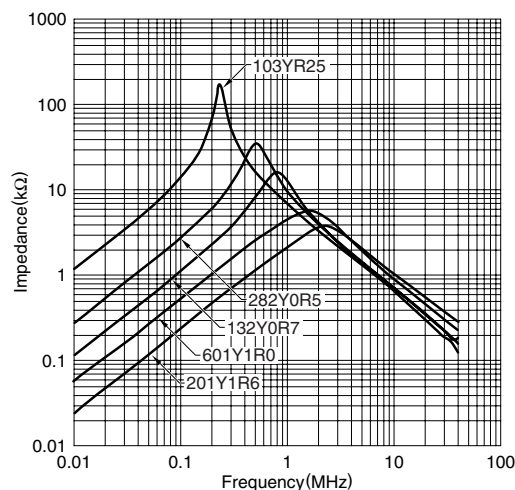

ELECTRICAL CHARACTERISTICS

(STANDARD LINE UP)

Part No.	Inductance (mH)min.	DC resistance (Ω)max.	Rated current Iac(A)max.
UF1717V-103YR25-02	10	3.5	0.25
UF1717V-702Y0R3-01	7	2.5	0.3
UF1717V-342Y0R4-01	3.4	1.3	0.4
UF1717V-282Y0R5-01	2.8	1	0.5
UF1717V-152Y0R6-01	1.5	0.55	0.6
UF1717V-132Y0R7-01	1.3	0.5	0.7
UF1717V-601Y1R0-01	0.6	0.2	1
UF1717V-201Y1R6-01	0.2	0.1	1.6
UF1717H-103YR25-01	10	3.5	0.25
UF1717H-702Y0R3-01	7	2.5	0.3
UF1717H-342Y0R4-01	3.4	1.3	0.4
UF1717H-282Y0R5-01	2.8	1	0.5
UF1717H-152Y0R6-01	1.5	0.55	0.6
UF1717H-132Y0R7-01	1.3	0.5	0.7
UF1717H-601Y1R0-01	0.6	0.2	1
UF1717H-201Y1R6-01	0.2	0.1	1.6

- Measuring equipment of inductance value:
LCR meter(HP4261A, HP4263B or equivalent)[f=1kHz]

PACKAGING QUANTITIES

UF1717V	640pieces/box
UF1717H	480pieces/box

RATINGS

Item	Standard value	Conditions
Rated voltage(V)	80 to 280	50Hz/60Hz
Dielectric withstanding voltage(V)	2000	Between each winding for 1 minute
Insulation resistance (M Ω)	100min.	Between each winding for DC.500V
Temperature rise($^{\circ}$ C)	45max.	With line resistance
Operating temperature range($^{\circ}$ C)	-20 to +120	Including self-temperature rise
Storage temperature range($^{\circ}$ C)	-20 to +85	
Resistance to soldering temperature*1	260 \pm 5 $^{\circ}$ C, 10 \pm 1sec	Solder bath method
Applicable safety standard*2	350 \pm 5 $^{\circ}$ C, 5sec max.	Soldering iron method
	Electrical Appliance and Material Safety Law ("DENAN"), IEC60065, UL6500, CSA C22.2	

*1 Pb free solder(Sn-3Ag-0.5Cu)

*2 However, this product is not recognized by each regulations.

Two Sections Bobbin Type(For High Frequency) UF Series

FEATURES

- This series is designed to reduce stray capacity between windings by using a single-layer coil construction on Ni-Zn ferrite cores, which offer excellent high frequency characteristics.
- This series provides excellent noise suppression for high frequency ranges including the FM band.
- Since the windings are divided into two sections, this filter can also be used as a signal line with excellent withstanding voltage.

UF1717V(2 SEPARABLE BOBBIN FOR HIGH FREQUENCY) TYPE SHAPES AND DIMENSIONS/CIRCUIT DIAGRAM

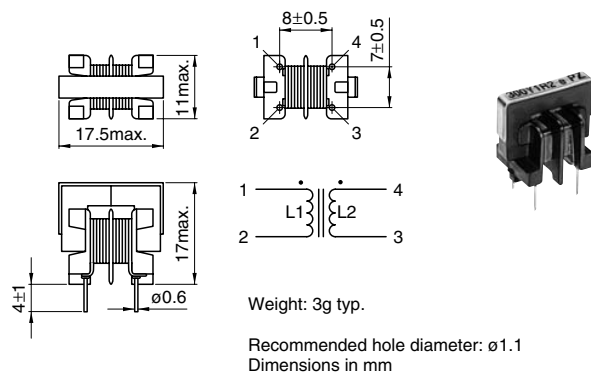

TYPICAL ELECTRICAL CHARACTERISTICS IMPEDANCE vs. FREQUENCY CHARACTERISTICS

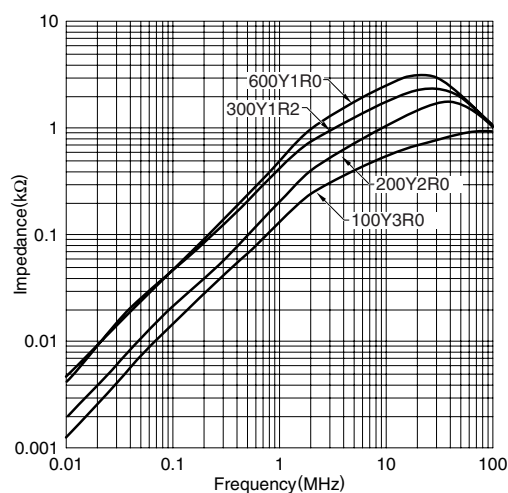

ELECTRICAL CHARACTERISTICS (STANDARD LINE UP)

Part No.	Inductance (μH)min.	DC resistance ($\text{m}\Omega$)max.	Rated current Iac(A)max.
UF1717V-600Y1R0-03	60	300	1
UF1717V-300Y1R2-03	30	150	1.2
UF1717V-200Y2R0-03	20	100	2
UF1717V-100Y3R0-03	10	50	3

- Measuring equipment of inductance value:
LCR meter(HP4261A, HP4263B or equivalent)[f=1kHz]

PACKAGING QUANTITIES

UF1717V	640pieces/box
---------	---------------

RATINGS

Item	Standard value	Conditions
Rated voltage(V)	80 to 280	50Hz/60Hz
Dielectric withstanding voltage(V)	2000	Between each winding for 1 minute
Insulation resistance ($\text{M}\Omega$)	100min.	Between each winding for DC.500V
Temperature rise($^{\circ}\text{C}$)	45max.	With line resistance
Operating temperature range($^{\circ}\text{C}$)	-20 to +120	Including self-temperature rise
Storage temperature range($^{\circ}\text{C}$)	-20 to +85	
Resistance to soldering temperature*1	260 \pm 5 $^{\circ}\text{C}$, 10 \pm 1sec	Solder bath method
Applicable safety standard*2	350 \pm 5 $^{\circ}\text{C}$, 5sec max.	Soldering iron method
	Electrical Appliance and Material Safety Law ("DENAN"), IEC60065, UL6500, CSA C22.2	

*1 Pb free solder(Sn-3Ag-0.5Cu)

*2 However, this product is not recognized by each regulations.

Two Sections Bobbin Type(For High Frequency) UF Series

FEATURES

- This series uses a Mn-Zn ferrite core and yet it offers excellent noise suppression into the high frequencies due to its low distributed inductance construction based on a single layer winding.
- This compact filters's inductance has been improved by as much as 50% compared to existing products of comparable size while its height profile has been reduced by approximately 30%.

UF1815SG(2 SEPARABLE BOBBIN FOR HIGH FREQUENCY) TYPE

SHAPES AND DIMENSIONS/CIRCUIT DIAGRAM

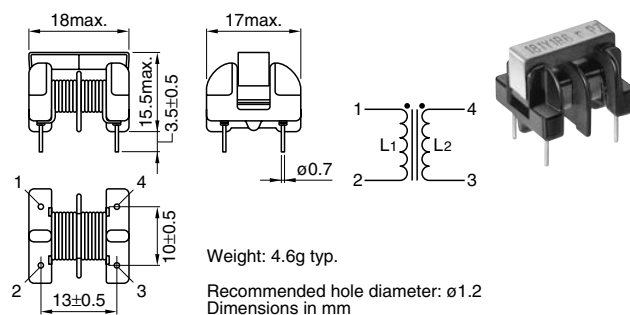

TYPICAL ELECTRICAL CHARACTERISTICS IMPEDANCE vs. FREQUENCY CHARACTERISTICS

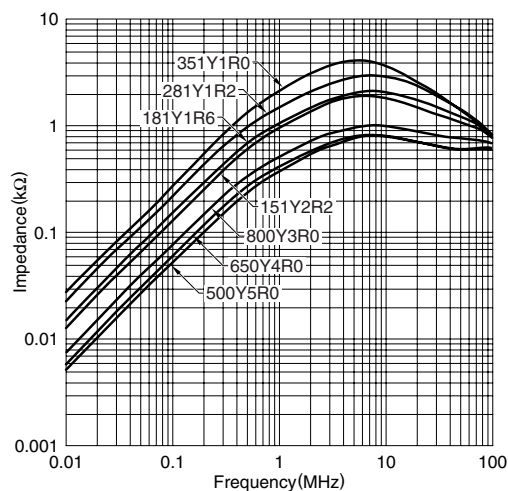

ELECTRICAL CHARACTERISTICS (STANDARD LINE UP)

Part No.	Inductance (μH)min.	DC resistance (mΩ)max.	Rated current Iac(A)max.
UF1815SG-351Y1R0-01	350	300	1
UF1815SG-281Y1R2-01	280	250	1.2
UF1815SG-181Y1R6-01	180	130	1.6
UF1815SG-151Y2R2-01	150	100	2.2
UF1815SG-800Y3R0-01	80	50	3
UF1815SG-650Y4R0-01	65	30	4
UF1815SG-500Y5R0-01	50	25	5

- Measuring equipment of inductance value:
LCR meter(HP4261A, HP4263B or equivalent)[f=1kHz]

PACKAGING QUANTITIES

UF1815SG	1280pieces/box
----------	----------------

RATINGS

Item	Standard value	Conditions
Rated voltage(V)	80 to 280	50Hz/60Hz
Dielectric withstanding voltage(V)	2000	Between each winding for 1 minute
Insulation resistance (MΩ)	100min.	Between each winding for DC.500V
Temperature rise(°C)	45max.	With line resistance
Operating temperature range(°C)	-20 to +120	Including self-temperature rise
Storage temperature range(°C)	-20 to +85	
Resistance to soldering temperature*1	260±5°C, 10±1sec	Solder bath method
Applicable safety standard*2	350±5°C, 5sec max.	Soldering iron method
	Electrical Appliance and Material Safety Law ("DENAN"), IEC60065, UL6500, CSA C22.2	

*1 Pb free solder(Sn-3Ag-0.5Cu)

*2 However, this product is not recognized by each regulations.