

# CM0805D900R-10

**UNCONTROLLED DOCUMENT**

**PHYSICAL DIMENSIONS:**

A	2.00 [.079]	+ 0.20 [.008]
B	1.20 [.047]	+ 0.20 [.008]
C	1.20 [.047]	+ 0.20 [.008]
D	0.15 [.006]	+ 0.10 [.004]

T1	0.55 [.022]	+ 0.10 [.004]
T2	0.46 [.018]	+ 0.10 [.004]

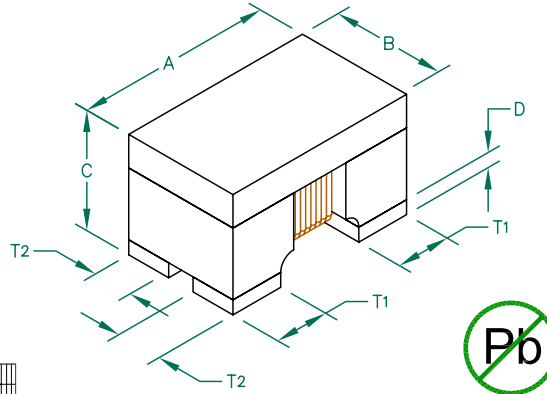

Electrical Characteristics		Nominal	Min	Max
Common Mode Impedance @ 100MHz	( $\Omega$ )	90	67.5	112.5
DCR	( $\Omega$ )	-	-	0.3
Rated Current	(mA)	-	-	400

- NOTES: UNLESS OTHERWISE SPECIFIED
1. TAPED AND REELED per CURRENT EIA SPECIFICATIONS 7" REELS, EMBOSSED PLASTIC TAPE 2,000 PCS/REEL.
  2. TERMINATION FINISH 100% MATTE TIN.
  3. COMPONENTS SHOULD BE ADEQUATELY PREHEATED BEFORE SOLDERING.

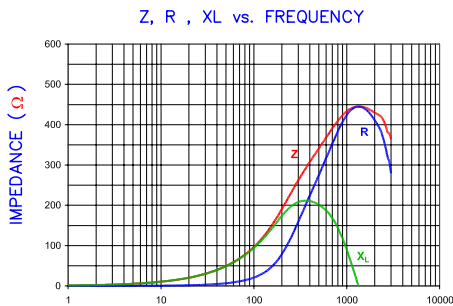

**LAND PATTERNS FOR REFLOW SOLDERING**

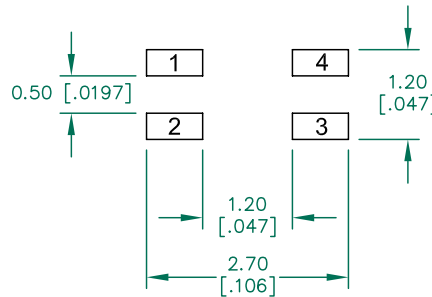
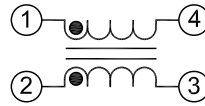

**RECOMMENDED SOLDERING CONDITIONS**

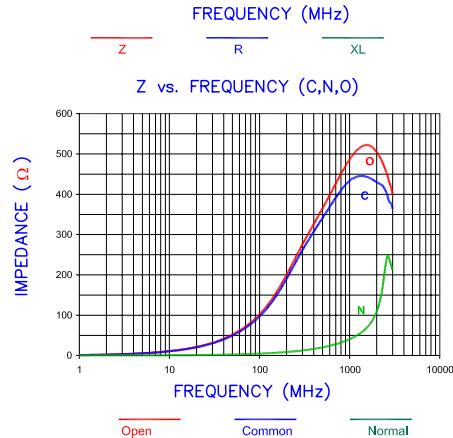
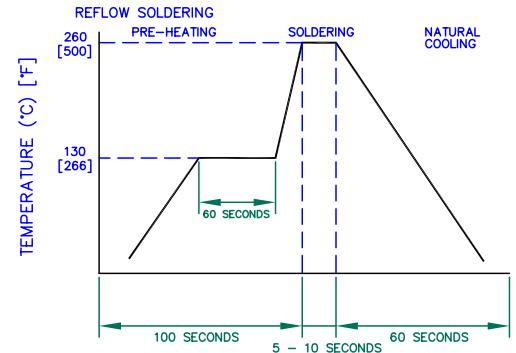

DIMENSIONS ARE IN mm [INCHES].				This print is the property of Laird Tech. and is loaned in confidence subject to return upon request and with the understanding that no copies shall be made without the written consent of Laird Tech. All rights to design or invention are reserved.			
D	UPDATE SOLDERING TEMPERATURE	04/01/11	WEI	PROJECT/PART NUMBER: <b>CM0805D900R-10</b>			
C	UPDATE COMPANY LOGO	04/28/09	JRK	REV	D	PART TYPE: CM CHOKE	DRAWN BY: JRK
B	UPDATE COMPANY LOGO	05/14/07	JRK	DATE:	08/11/06	SCALE: NTS	SHEET: 2 of 2
A	ORIGINAL DRAFT	08/11/06	JRK	CAD #	CM0805D900R-10-D	TOOL #	-
REV	DESCRIPTION	DATE	INT				



AGILENT E4991A RF Impedance/Material Analyzer  
HP 16194A Test Fixture. TEST REF. 5788