

## 400mA LOAD SWITCH FEATURING PNP TRANSISTOR AND N-MOSFET WITH GATE PULL-DOWN RESISTOR

NEW PRODUCT

### General Description

- LMN400B01 is best suited for applications where the load needs to be turned on and off using control circuits like micro-controllers, comparators etc. particularly at a point of load. It features a discrete pass transistor with stable  $V_{CE(SAT)}$  which does not depend on input voltage and can support continuous maximum current of 400 mA. It also contains a discrete N-MOSFET with gate pull-down resistor that can be used as control. The component devices can be used as a part of a circuit or as a stand alone discrete device.

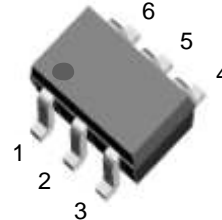

Fig. 1: SOT-26

### Features

- Voltage Controlled Small Signal Switch
- N-MOSFET with Gate Pull-Down Resistor
- Surface Mount Package
- Ideally Suited for Automated Assembly Processes
- Lead Free By Design/ROHS Compliant (Note 1)**
- "Green" Device (Note 2)**

### Mechanical Data

- Case: SOT-26
- Case Material: Molded Plastic, "Green" Molding Compound. UL Flammability Classification Rating 94V-0
- Moisture sensitivity: Level 1 per J-STD-020C
- Terminal Connections: See Diagram
- Terminals: Finish - Matte Tin annealed over Copper leadframe. Solderable per MIL-STD-202, Method 208
- Marking & Type Code Information: See Last Page
- Ordering Information: See Last Page
- Weight: 0.016 grams (approx.)

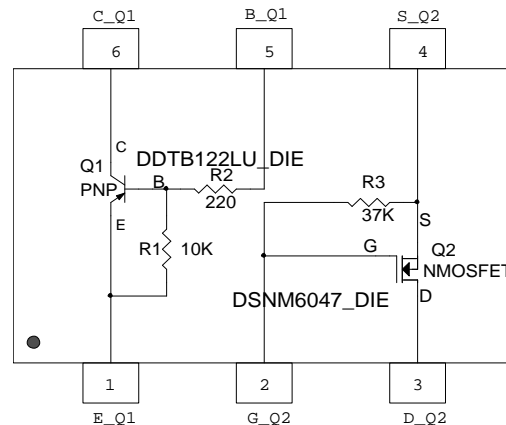

Fig. 2 Schematic and Pin Configuration

Sub-Components	Reference	Device Type	R1 (NOM)	R2 (NOM)	R3 (NOM)	Figure
DDTB122LU_DIE	Q1	PNP Transistor	10K	220		2
DSNM6047_DIE (with Gate Pull-Down Resistor)	Q2	N-MOSFET			37K	2

### Maximum Ratings, Total Device @ $T_A = 25^\circ\text{C}$ unless otherwise specified

Characteristic	Symbol	Value	Unit
Power Dissipation (Note 3)	$P_d$	300	mW
Power Derating Factor above $100^\circ\text{C}$	$P_{der}$	2.4	mW/ $^\circ\text{C}$
Output Current	$I_{out}$	400	mA

### Thermal Characteristics

Characteristic	Symbol	Value	Unit
Junction Operation and Storage Temperature Range	$T_j, T_{stg}$	-55 to +150	$^\circ\text{C}$
Thermal Resistance, Junction to Ambient Air (Note 3) (Equivalent to one heated junction of PNP transistor)	$R_{JA}$	417	$^\circ\text{C/W}$

- Notes:
- No purposefully added lead.
  - Diodes Inc.'s "Green" policy can be found on our website at [http://www.diodes.com/products/lead\\_free/index.php](http://www.diodes.com/products/lead_free/index.php).
  - Device mounted on FR-4 PCB, 1 inch x 0.85 inch x 0.062 inch; pad layout as shown on Diodes Inc. suggested pad layout document AP02001, which can be found on our website at <http://www.diodes.com/datasheets/ap02001.pdf>.

**Maximum Ratings:**
**Sub-Component Device: Pre-Biased PNP Transistor (Q1)** @  $T_A = 25^\circ\text{C}$  unless otherwise specified

Characteristic	Symbol	Value	Unit
Collector-Base Voltage	$V_{CBO}$	-50	V
Collector-Emitter Voltage	$V_{CEO}$	-50	V
Supply Voltage	$V_{CC}$	-50	V
Input Voltage	$V_{in}$	+5 to -6	V
Output Current	$I_C$	-400	mA

**Sub-Component Device:**
**N-MOSFET with Gate Pull-Down Resistor (Q2)** @  $T_A = 25^\circ\text{C}$  unless otherwise specified

Characteristic	Symbol	Value	Unit
Drain-Source Voltage	$V_{DSS}$	60	V
Drain Gate Voltage ( $R_{GS} = 1\text{M}\Omega$ )	$V_{DGR}$	60	V
Gate-Source Voltage	$V_{GSS}$	Continuous	+/-20
		Pulsed ( $t_p < 50 \mu\text{s}$ )	+/-40
Drain Current (Page 1: Note 3)	$I_D$	Continuous ( $V_{GS} = 10\text{V}$ )	115
		Pulsed ( $t_p < 10 \mu\text{s}$ , Duty Cycle <1%)	800
Continuous Source Current	$I_S$	115	mA

## Electrical Characteristics:

### Pre-Biased PNP Transistor (Q1) @ $T_A = 25^\circ\text{C}$ unless otherwise specified

Characteristic	Symbol	Min	Typ	Max	Unit	Test Condition
<b>OFF CHARACTERISTICS</b>						
Collector-Base Cut Off Current	$I_{CBO}$			-100	nA	$V_{CB} = -50V, I_E = 0$
Collector-Emitter Cut Off Current	$I_{CEO}$			-500	nA	$V_{CE} = -50V, I_B = 0$
Emitter-Base Cut Off Current	$I_{EBO}$			-1	mA	$V_{EB} = -5V, I_C = 0$
Collector-Base Breakdown Voltage	$V_{(BR)CBO}$	-50			V	$I_C = -10 \mu A, I_E = 0$
Collector-Emitter Breakdown Voltage	$V_{(BR)CEO}$	-50			V	$I_C = -2 \text{ mA}, I_B = 0$
Input Off Voltage	$V_{I(OFF)}$			-0.5	V	$V_{CE} = -5V, I_C = -100\mu A$
Output Voltage	$V_{OH}$	-4.9			V	$V_{CC} = -5V, V_B = -0.05V, R_L = 1K$
Output Current (leakage current same as $I_{CEO}$ )	$I_{O(OFF)}$			-500	nA	$V_{CC} = -50V, V_I = 0V$
<b>ON CHARACTERISTICS</b>						
Collector-Emitter Saturation Voltage	$V_{CE(SAT)}$		-0.055	-0.15	V	$I_C = -10\text{mA}, I_B = -0.3\text{mA}$
			-0.25	-0.3	V	$I_C = -100\text{mA}, I_B = -1\text{mA}$
			-0.12	-0.15	V	$I_C = -200\text{mA}, I_B = -20\text{mA}$
			-0.16	-0.2	V	$I_C = -300\text{mA}, I_B = -30\text{mA}$
			-0.2	-0.25	V	$I_C = -400\text{mA}, I_B = -40\text{mA}$
		-0.25	-0.3	V	$I_C = -500\text{mA}, I_B = -50\text{mA}$	
Equivalent on-resistance*	$R_{CE(SAT)}$			1.125		$I_C = 400\text{mA}, I_B = 20\text{mA}$
DC Current Gain	$h_{FE}$	70	220			$V_{CE} = -5V, I_C = -50 \text{ mA}$
		70	260			$V_{CE} = -5V, I_C = -100 \text{ mA}$
		70	265			$V_{CE} = -5V, I_C = -200 \text{ mA}$
		70	225			$V_{CE} = -5V, I_C = -400 \text{ mA}$
Input On Voltage	$V_{I(ON)}$	-2.45	-1.5		V	$V_O = -0.3V, I_C = -2 \text{ mA}$
Output Voltage (equivalent to $V_{CE(SAT)}$ or $V_{O(on)}$ )	$V_{OL}$		-0.1	-0.3	V	$V_{CC} = -5V, V_B = -2.5V, I_O/I_I = -50\text{mA} / -2.5\text{mA}$
Input Current	$I_i$		-18	-28	mA	$V_I = -5V$
Base-Emitter Turn-on Voltage	$V_{BE(ON)}$		-1.2	-1.3	V	$V_{CE} = -5V, I_C = -400\text{mA}$
Base-Emitter Saturation Voltage	$V_{BE(SAT)}$		-1.9	-2.2	V	$I_C = -50\text{mA}, I_B = -5\text{mA}$
			-5.25	-5.5	V	$I_C = -400\text{mA}, I_B = -20\text{mA}$
Input Resistor (Base), +/- 30%	R2		0.22		K	
Pull-up Resistor (Base to $V_{CC}$ supply), +/- 30%	R1		10		K	
Resistor Ratio (Input Resistor/Pullup resistor)	R1/R2		0.022			
<b>SMALL SIGNAL CHARACTERISTICS</b>						
Transition Frequency (gain bandwidth product)	$f_T$		200		MHz	$V_{CE} = -10V, I_E = -5\text{mA}, f = 100\text{MHz}$
Collector capacitance, ( $C_{cbo}$ -Output Capacitance)	$C_C$		20		pF	$V_{CB} = -10V, I_E = 0A, f = 1\text{MHz}$

\* Pulse Test: Pulse width,  $t_p < 300 \mu\text{s}$ , Duty Cycle,  $d = 0.02$

**Electrical Characteristics:**

**N-MOSFET with Gate Pull-Down Resistor (Q2) @  $T_A = 25^\circ\text{C}$  unless otherwise specified**

Characteristic	Symbol	Min	Typ	Max	Unit	Test Condition
<b>OFF CHARACTERISTICS (Note 4)</b>						
Drain-Source Breakdown Voltage, BVDSS	$V_{(BR)DSS}$	60			V	$V_{GS} = 0V, I_D = 10\mu A$
Zero Gate Voltage Drain Current (Drain Leakage Current)	$I_{DSS}$			1	$\mu A$	$V_{GS} = 0V, V_{DS} = 60V$
Gate-Body Leakage Current, Forward	$I_{GSSF}$			0.95	mA	$V_{GS} = 20V, V_{DS} = 0V$
Gate-Body Leakage Current, Reverse	$I_{GSSR}$			-0.95	mA	$V_{GS} = -20V, V_{DS} = 0V$
<b>ON CHARACTERISTICS (Note 4)</b>						
Gate Source Threshold Voltage (Control Supply Voltage)	$V_{GS(th)}$	1	1.86	2.2	V	$V_{DS} = V_{GS}, I_D = 0.25mA$
Static Drain-Source On-State Voltage	$V_{DS(on)}$		0.08	1.5	V	$V_{GS} = 5V, I_D = 50mA$
			0.15	3.75		$V_{GS} = 10V, I_D = 115mA$
On-State Drain Current	$I_{D(on)}$	500			mA	$V_{GS} = 10V, V_{DS} = 2 \times V_{DS(on)}$
Static Drain-Source On Resistance	$R_{DS(on)}$		1.55	3		$V_{GS} = 5V, I_D = 50mA$
			1.4	2		$V_{GS} = 10V, I_D = 500mA$
Forward Transconductance	$g_{FS}$	80	240		mS	$V_{DS} = 2 \times V_{DS(on)}, I_D = 115mA$
		80	350			$V_{DS} = 2 \times V_{DS(on)}, I_D = 200mA$
Gate Pull-Down Resistor, +/- 30%	R3		37		K	
<b>DYNAMIC CHARACTERISTICS</b>						
Input Capacitance	$C_{iss}$			50	pF	$V_{DS} = -25V, V_{GS} = 0V, f = 1MHz$
Output Capacitance	$C_{oss}$			25	pF	
Reverse Transfer Capacitance	$C_{rss}$			5	pF	
<b>SWITCHING CHARACTERISTICS*</b>						
Turn-On Delay Time	$t_{d(on)}$			20	ns	$V_{DD} = 30V, V_{GS} = 10V, I_D = 200mA, R_G = 25, R_L = 150$
Turn-Off Delay Time	$t_{d(off)}$			40	ns	
<b>SOURCE-DRAIN (BODY) DIODE CHARACTERISTICS AND MAXIMUM RATINGS</b>						
Drain-Source Diode Forward On-Voltage	$V_{SD}$		0.88	1.5	V	$V_{GS} = 0V, I_S = 115mA^*$
Maximum Continuous Drain-Source Diode Forward Current (Reverse Drain Current)	$I_S$			115	mA	
Maximum Pulsed Drain-Source Diode Forward Current	$I_{SM}$			800	mA	

\* Pulse Test: Pulse width,  $t_p < 300 \mu s$ , Duty Cycle,  $d = 0.02$

Notes: 4. Short duration test pulse used to minimize self-heating effect.

Typical Characteristics

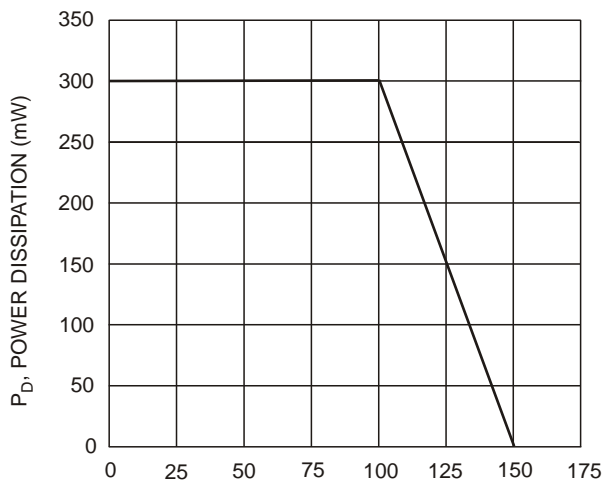

Fig. 3, Max Power Dissipation vs Ambient Temperature

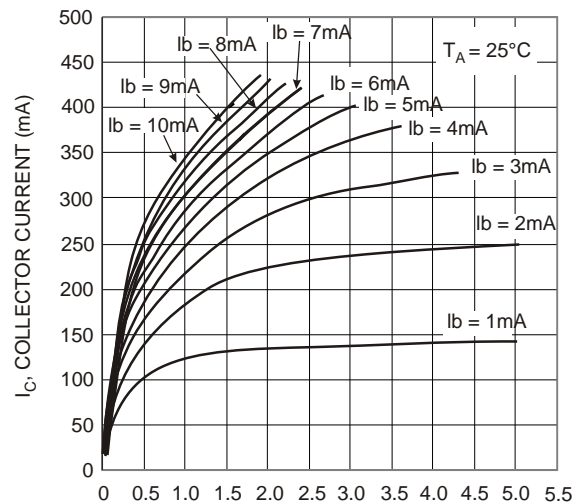

Fig. 4, Output Current vs. Voltage Drop (Pass Element PNP)

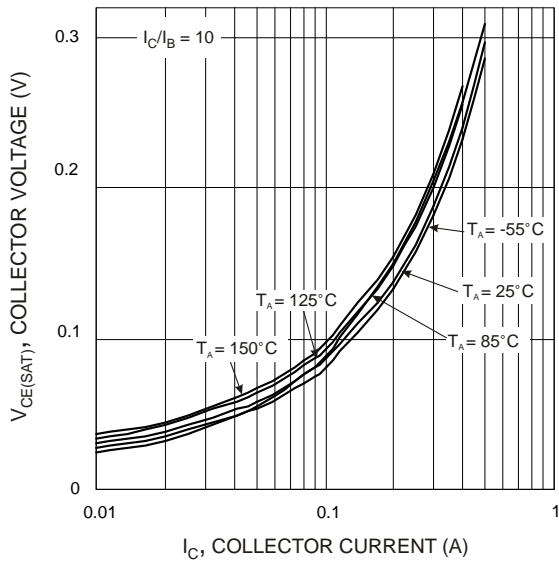

Fig. 5  $V_{CE(SAT)}$  vs.  $I_C$

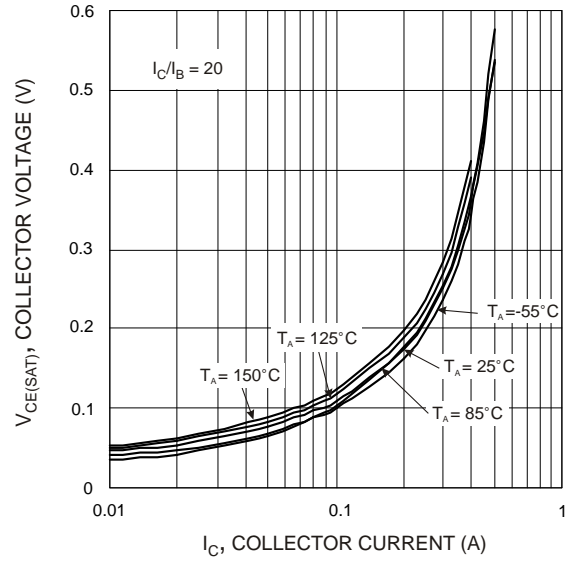

Fig. 6  $V_{CE(SAT)}$  vs.  $I_C$

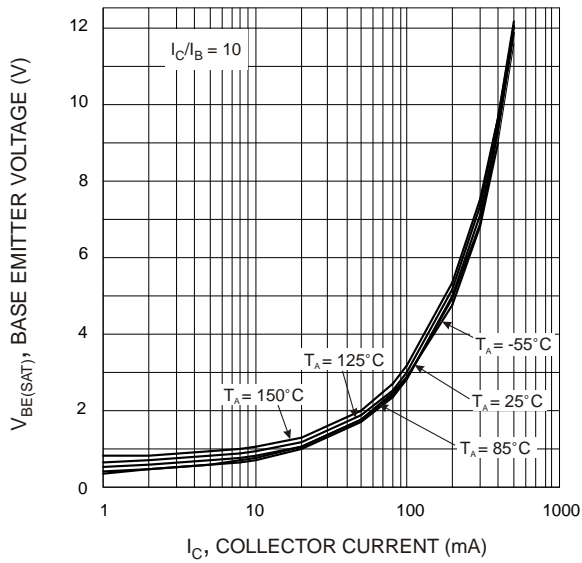

Fig. 7  $V_{BE(SAT)}$  vs.  $I_C$

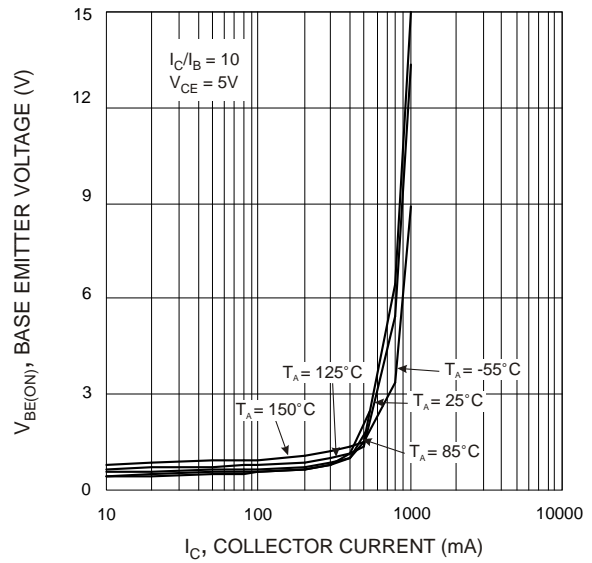

Fig. 8  $V_{BE(ON)}$  vs.  $I_C$

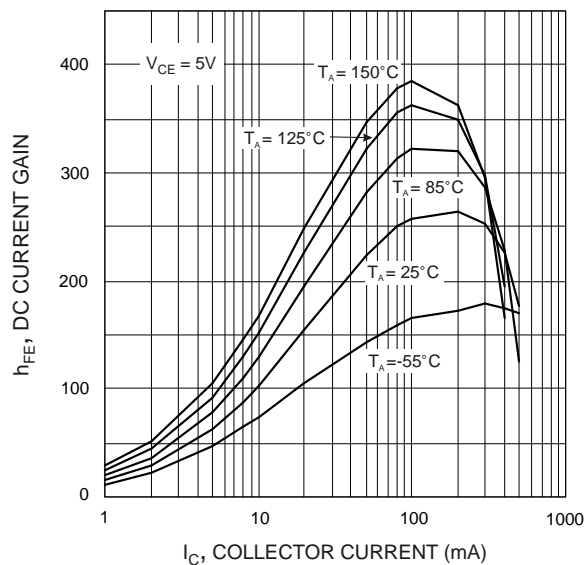
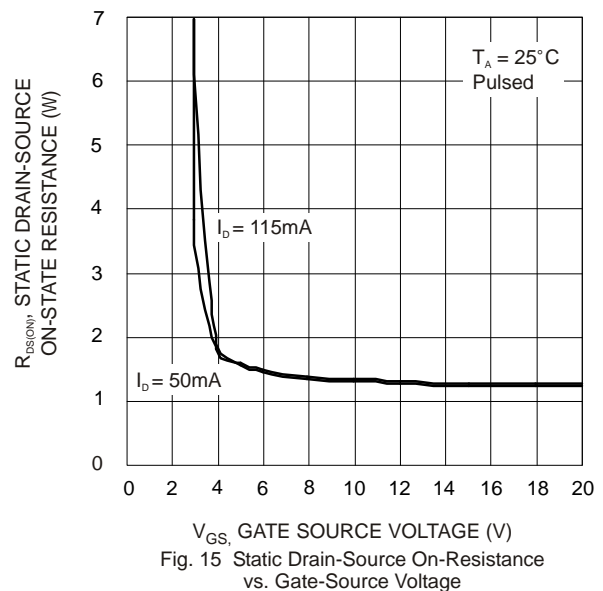
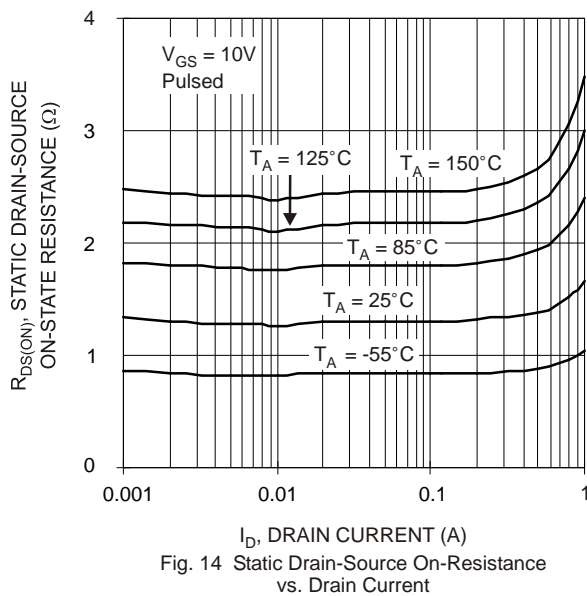
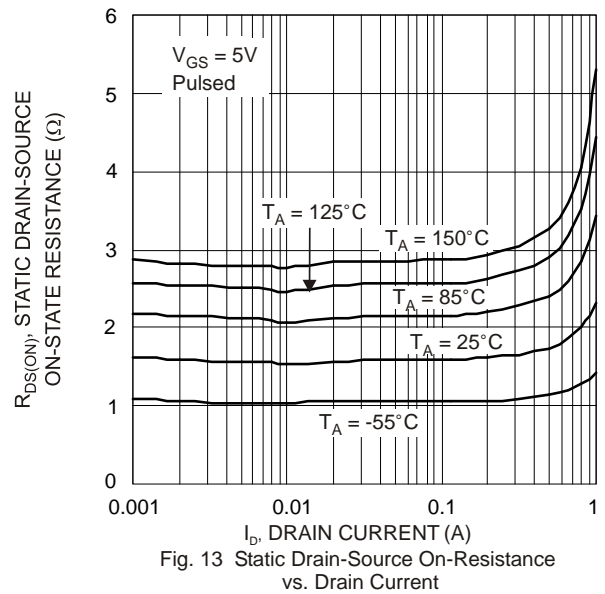
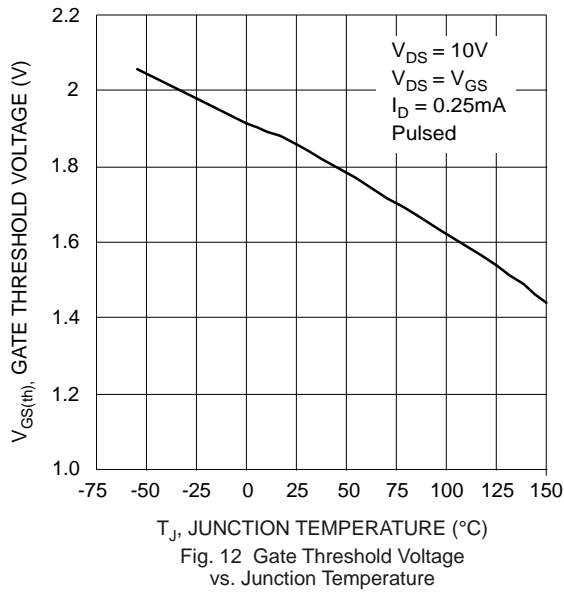
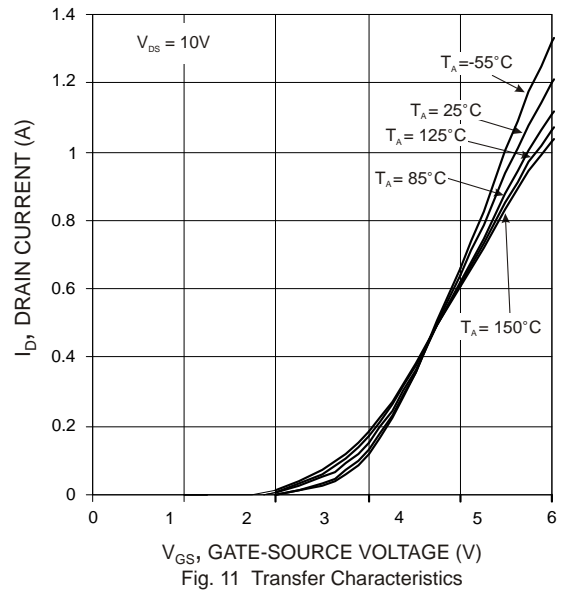
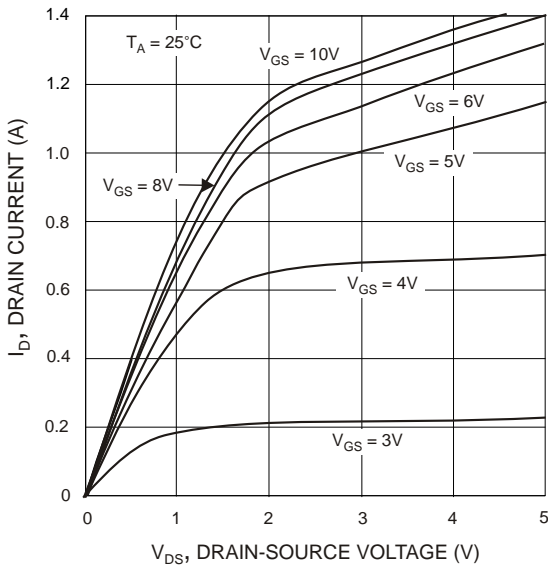

Fig. 9  $h_{FE}$  vs.  $I_C$



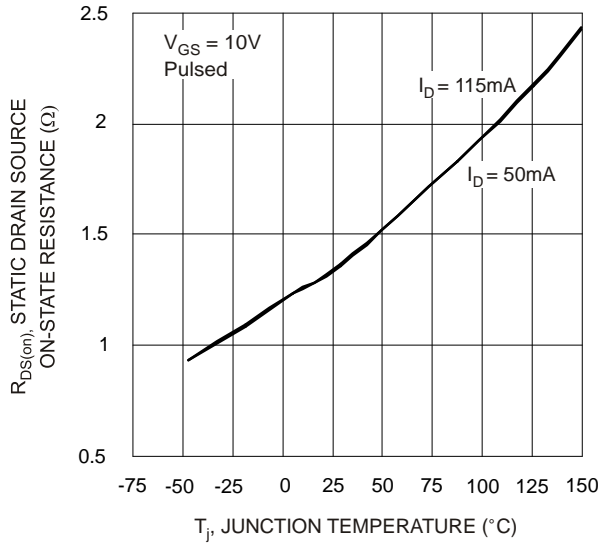

Fig. 16 Static Drain-Source On-State Resistance vs. Junction Temperature

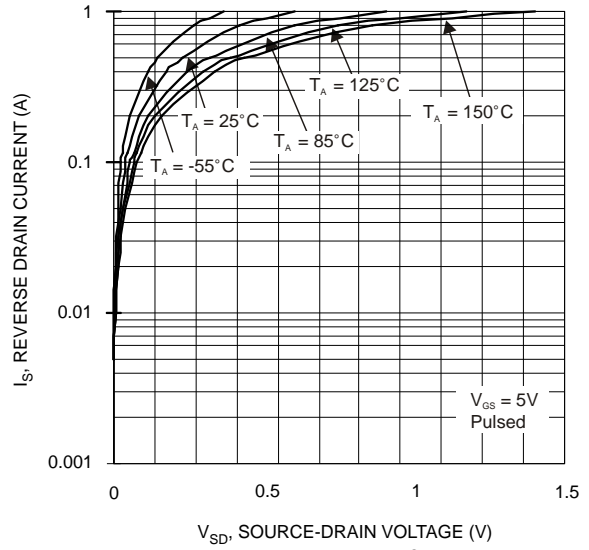

Fig. 17 Reverse Drain Current vs. Source-Drain Voltage

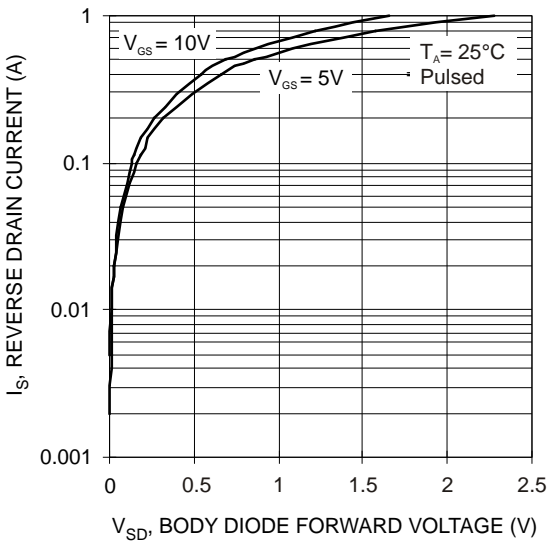

Fig. 18 Reverse Drain Current vs. Body Diode Forward Voltage

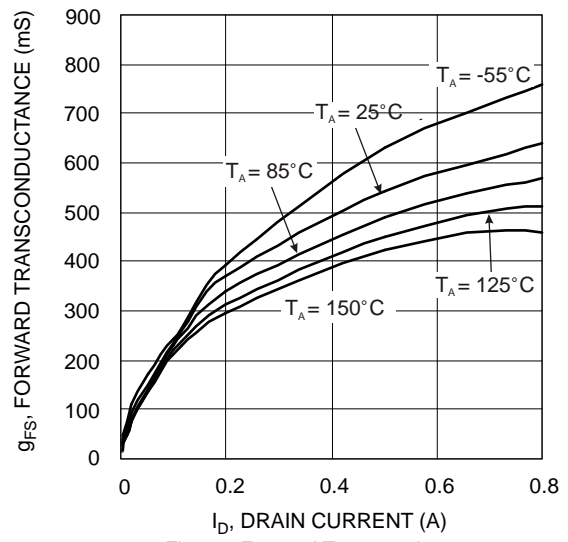

Fig. 19 Forward Transconductance vs. Drain Current ( $V_{DS} > I_D \cdot R_{DS(on)}$ )

## Application Details

- PNP Transistor (DDTB122LU) and N-MOSFET (DSNM6047) with gate pull-down resistor integrated as one in LMN400B01 can be used as a discrete entity for general application or as an integrated circuit to function as a Load Switch. When it is used as the latter as shown in Fig 20, various input voltage sources can be used as long as it does not exceed the maximum ratings of the device. These devices are designed to deliver continuous output load current up to a maximum of 400 mA. The MOSFET Switch draws no current, hence loading of control circuit is prevented. Care must be taken for higher level of dissipation while designing for higher load conditions. These devices provide high power and also consumes less space. The product mainly helps in optimizing power usage, thereby conserving battery life in a controlled load system like portable battery powered applications. (Please see Fig. 21 for one example of a typical application circuit used in conjunction with voltage regulator as a part of power management system)

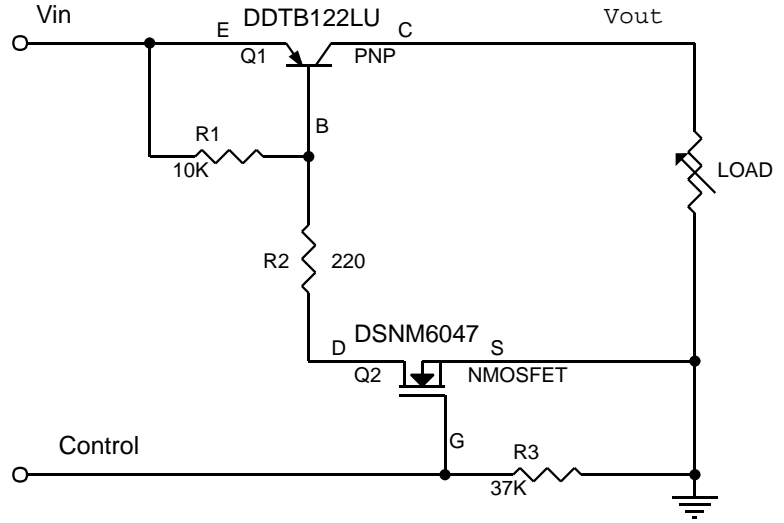

Fig 20 : Circuit Diagram

## Typical Application Circuit

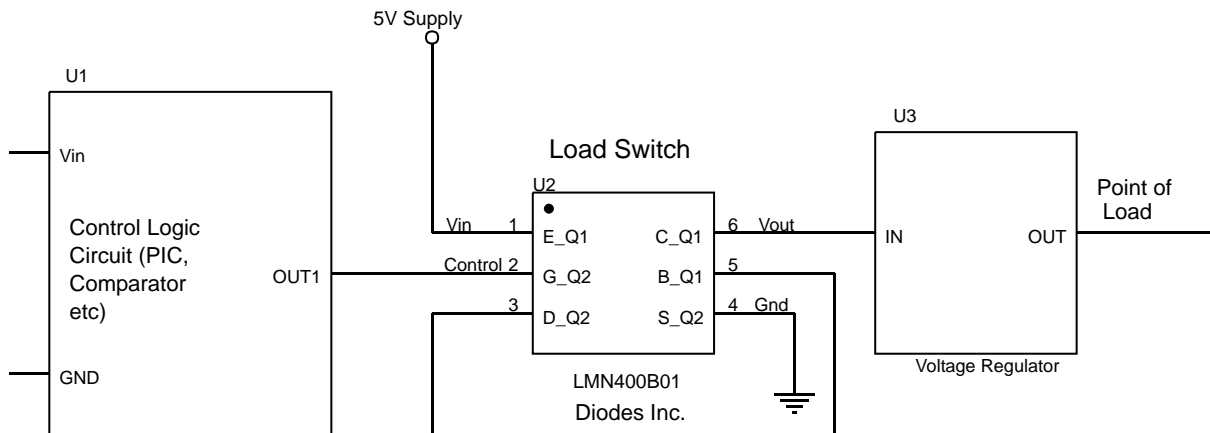

Fig 21



**Ordering Information** (Note 5)

Device	Marking Code	Packaging	Shipping
LMN400B01-7	PM3	SOT-26	3000/Tape & Reel

Note: 5. For Packaging Details, go to our website at <http://www.diodes.com/datasheets/ap02007.pdf>.

**Marking Information**

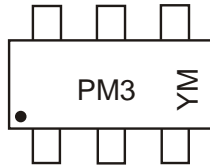

PM3 = Product Type Marking Code,  
 YM = Date Code Marking  
 Y = Year ex: T = 2006  
 M = Month ex: 9 = September

Fig. 22

Date Code Key

Year	2006	2007	2008	2009
Code	T	U	V	W

Month	Jan	Feb	March	Apr	May	Jun	Jul	Aug	Sep	Oct	Nov	Dec
Code	1	2	3	4	5	6	7	8	9	O	N	D

**Mechanical Details**

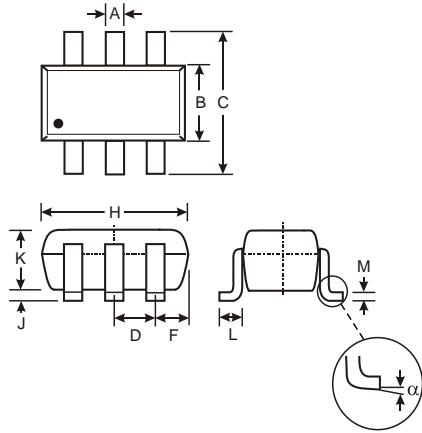

Fig. 23

SOT-26			
Dim	Min	Max	Typ
A	0.35	0.5	0.38
B	1.5	1.7	1.6
C	2.7	3	2.8
D	-	-	0.95
F	-	-	0.55
H	2.9	3.1	3
J	0.013	0.1	0.05
K	1	1.3	1.1
L	0.35	0.55	0.4
M	0.1	0.2	0.15
	0°	8°	-
All Dimensions in mm			

**Suggested Pad Layout: (Based on IPC-SM-782)**

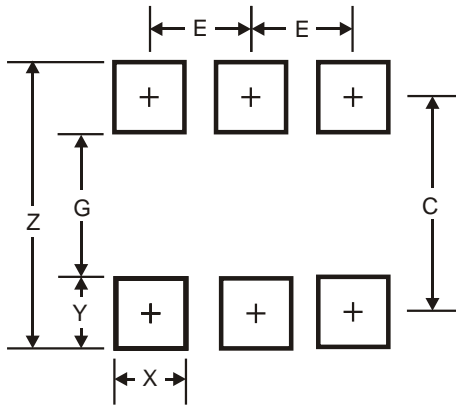

Fig. 24

Figure 24 Dimensions	SOT-26*
Z	3.2
G	1.6
X	0.55
Y	0.8
C	2.4
E	0.95

\* Typical dimensions in mm

**IMPORTANT NOTICE**

Diodes, Inc. and its subsidiaries reserve the right to make changes without further notice to any product herein to make corrections, modifications, enhancements, improvements, or other changes. Diodes, Inc. does not assume any liability arising out of the application or use of any product described herein; neither does it convey any license under its patent rights, nor the rights of others. The user of products in such applications shall assume all risks of such use and will agree to hold Diodes Incorporated and all the companies whose products are represented on our website, harmless against all damages.

**LIFE SUPPORT**

The products located on our website at [www.diodes.com](http://www.diodes.com) are not recommended for use in life support systems where a failure or malfunction of the component may directly threaten life or cause injury without the expressed written approval of Diodes Incorporated.