



The RH Series is an annular thermoelectric module (TEM) that is round in shape. The hot and cold side ceramics have a circular hole in the center to accommodate light protrusion for optics, mechanical fastening or temperature probe.

This product line is available in multiple configurations. Assembled with Bismuth Telluride semiconductor material and thermally conductive Aluminum Oxide ceramics, the RH Series is designed for higher current and larger heat-pumping applications.

### FEATURES

- Center hole
- Precise temperature control
- Reliable solid state operation
- No sound or vibration
- DC operation
- RoHS compliant

### APPLICATIONS

- Analytical instrumentation
- Clinical diagnostics
- Photonics laser systems
- Industrial Instrumentation
- Food & beverage cooling
- Consumer appliances

### PERFORMANCE SPECIFICATIONS

Hot Side Temperature (°C)	25	50
Qmax (Watts)	12.9	14.2
Delta Tmax (°C)	67	75
Imax (Amps)	6.0	6.0
Vmax (Volts)	3.7	4.1
Module Resistance (Ohms)	0.57	0.64

SUFFIX	THICKNESS (PRIOR TO TINNING)	FLATNESS & PARALLELISM	HOT FACE	COLD FACE	LEAD LENGTH
L	0.150" ± 0.010"	0.0015" / 0.0015"	Lapped	Lapped	4.5"
L1	0.150" ± 0.001"	0.001" / 0.001"	Lapped	Lapped	4.5"
L2	0.150" ± 0.0005"	0.0005" / 0.0005"	Lapped	Lapped	4.5"
MM	0.158" ± 0.010"	0.002" / 0.002"	Metallized	Metallized	4.5"

### SEALING OPTION

SUFFIX	SEALANT	COLOR	TEMP RANGE	DESCRIPTION
RT	RTV	White	-60 to 204 °C	Non-corrosive, silicone adhesive sealant
EP	Epoxy	Black	-55 to 150 °C	Low density syntactic foam epoxy encapsulant

### global solutions: local support™

Americas: +1 888.246.9050

Europe: +46.31.420530

Asia: +86.755.2714.1166

clv.customerpos@lairdtech.com

www.lairdtech.com

Performance Curves at  $T_h = 25^\circ\text{C}$

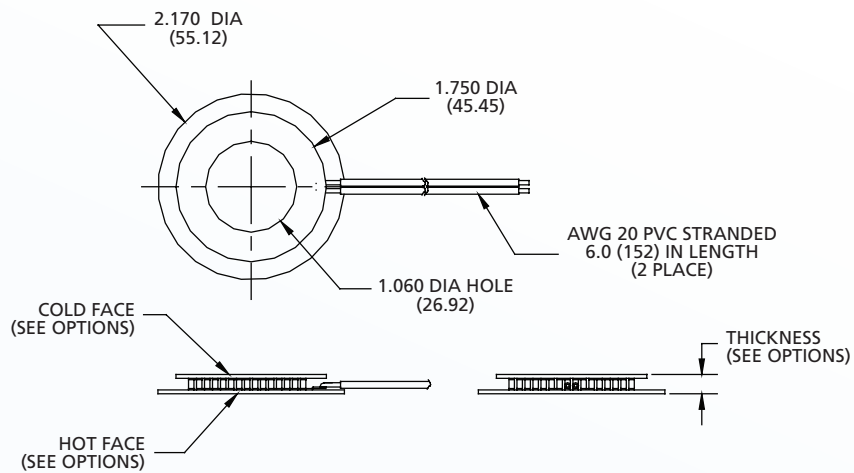
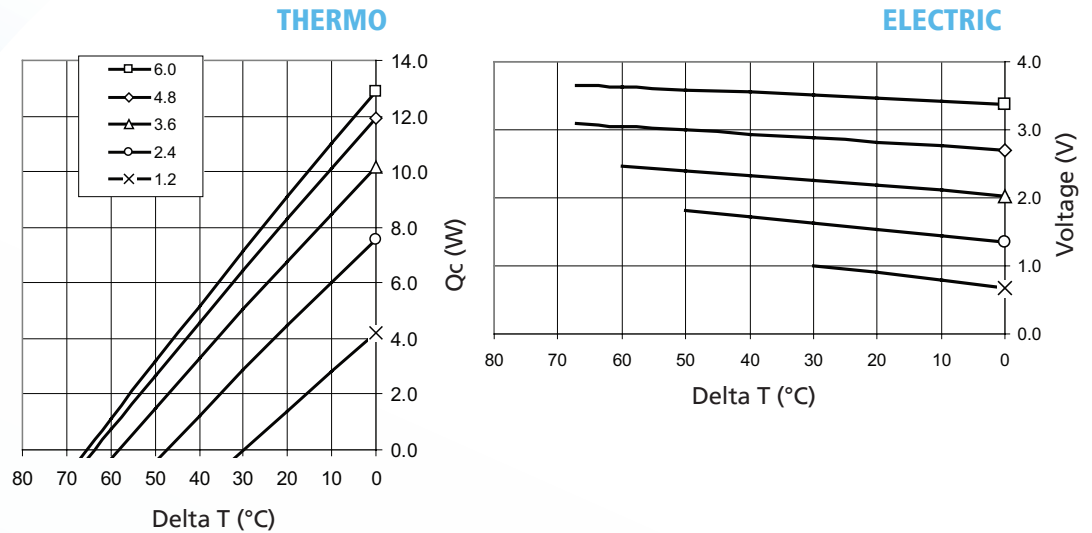

Ceramic Material: Alumina ( $\text{Al}_2\text{O}_3$ )  
Solder Construction:  $138^\circ\text{C}$ , Bismuth Tin (BiSn)

### OPERATING TIPS

- Max Operating Temperature:  $80^\circ\text{C}$
- Do not exceed  $I_{\text{max}}$  or  $V_{\text{max}}$  when operating module
- Reference assembly guidelines for recommended installation
- Solder tinning also available on metallized ceramics

THR-DS-RH14,32,06 0509

Any information furnished by Laird Technologies and its agents is believed to be accurate and reliable. Responsibility for the use and application of Laird Technologies materials rests with the end user since Laird Technologies and its agents cannot be aware of all potential uses. Laird Technologies makes no warranties as to the fitness, merchantability, or suitability of any Laird Technologies materials or products for any specific or general uses. Laird Technologies shall not be liable for incidental or consequential damages of any kind. All Laird Technologies products are sold pursuant to the Laird Technologies terms and conditions of sale in effect from time to time, a copy of which will be furnished upon request. For further information please visit our website at [www.lairdtech.com](http://www.lairdtech.com) Alternatively contact: [sales@lairdtech.com](mailto:sales@lairdtech.com). Bluetooth® is a trademark owned by Bluetooth SIG, Inc., USA and licensed to Laird Technologies.

© 2009 All Rights Reserved. Laird Technologies is a registered trademark of Laird Technologies, Inc.