

METAL CASE, CASE-MOUNTED SEMICONDUCTORS

LA363B5

Natural Conv. (°C/W): 11.1

Forced Air (°C/W): 3.9

Mounting Envelope: 1.63" x 1.29" x 1.25"

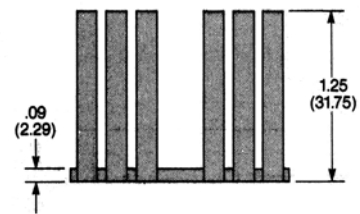
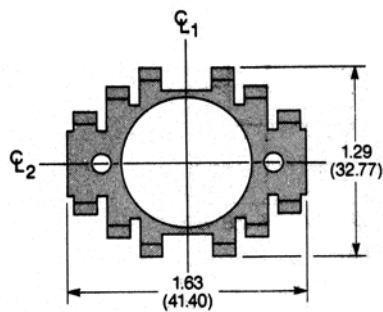

LA363B5CB w/2N3055 (TO-3) TRANSISTOR

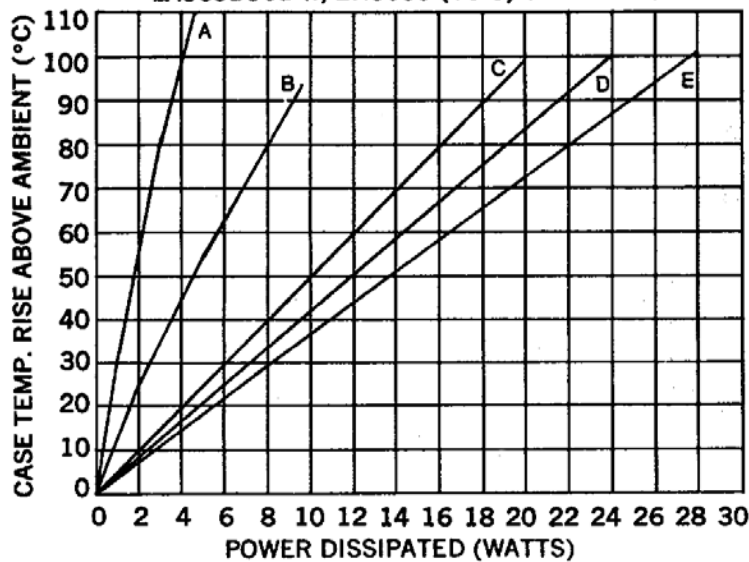

DESCRIPTION OF CURVES

- A. N.C. Horiz. Device Only Mounted to G-10.
- B. N.C Horiz. & Vert. With Dissipator.
- C. 200 FPM w/Diss.
- D. 500 FPM w/Diss.
- E. 1000 FPM w/Diss.

- Thermal Resistance Case to Sink is 1.0-1.4 °C/W w/Joint Compound.
- Derate 0.7 °C/watt for unplated part in natural convection only.

Ordering Information

CTS IERC PART NO.			Semiconductor Accommodated	Hole patt. ref. no.	Max. Weight (Grams)
Unplated	Comm'l. Black Anodize	Mil. Black Anodize			
LA363B5U	LA363B5CB	LA363B5B	Any TO-3 can	3	12.6

HOLE PATTERNS

3. Hole pattern no. 363 accommodates T0-3s or T0-3 ICs.
Available in LA-B series heat dissipators only.

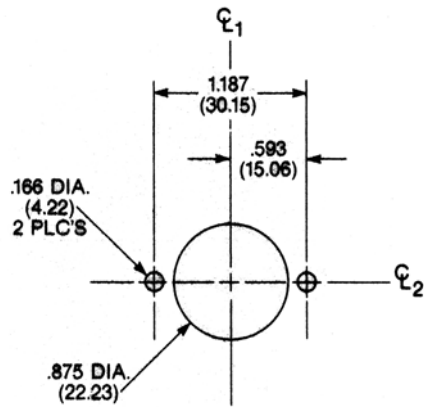

CTS IERC, Heat Sinks and Thermal Management Solutions

413 North Moss Street, Burbank, California 91502 Tel: (818) 842-7277 Fax: (818) 848-8872

Rev. 03-04-03