

8 7 6 5 4 3 2 1

E  
D  
C  
B  
A

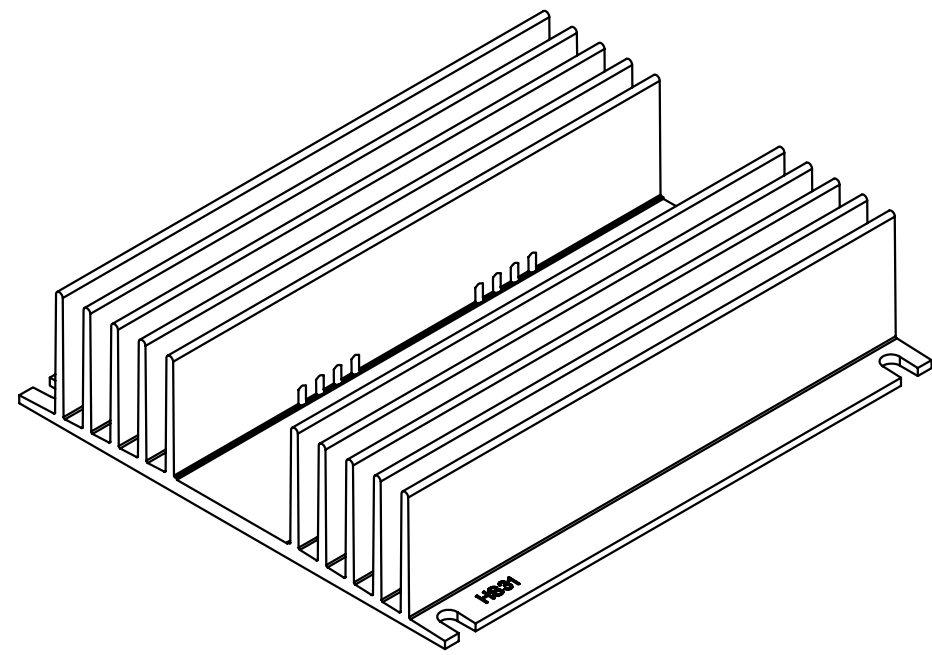
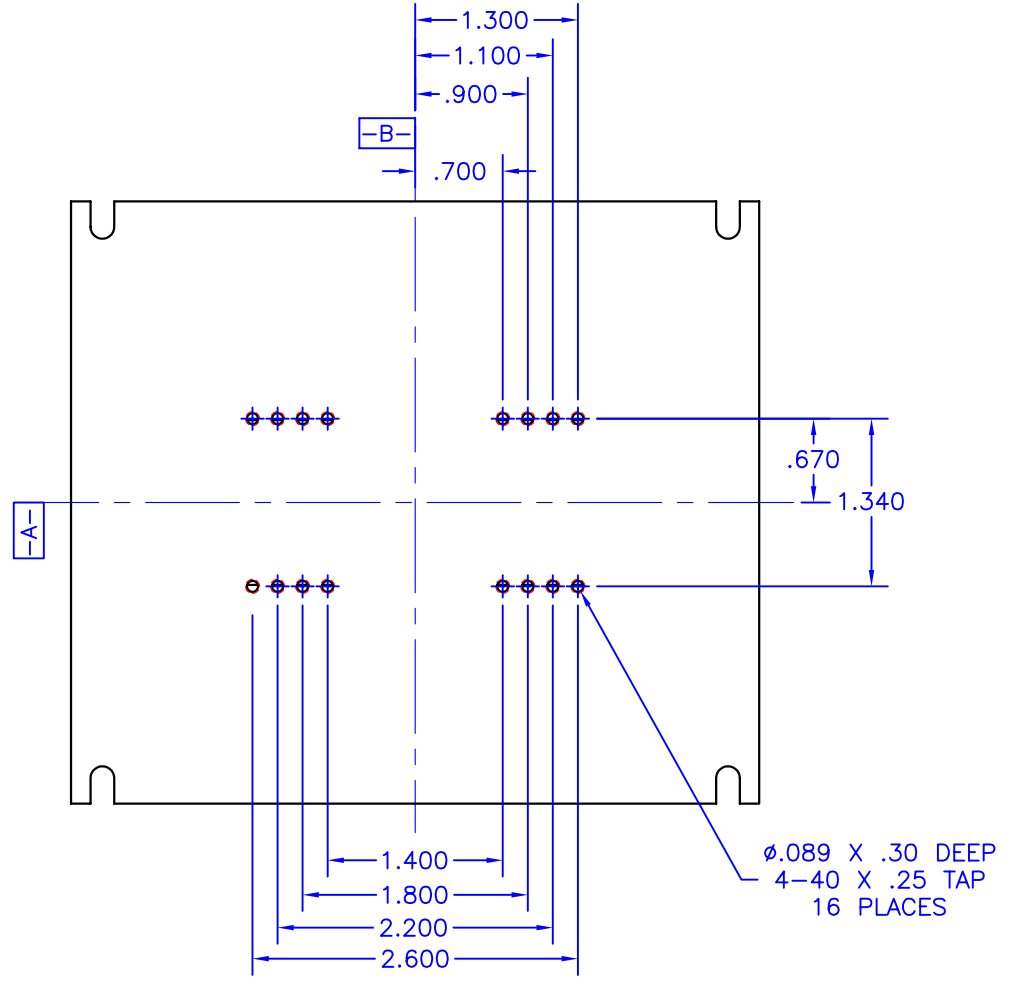
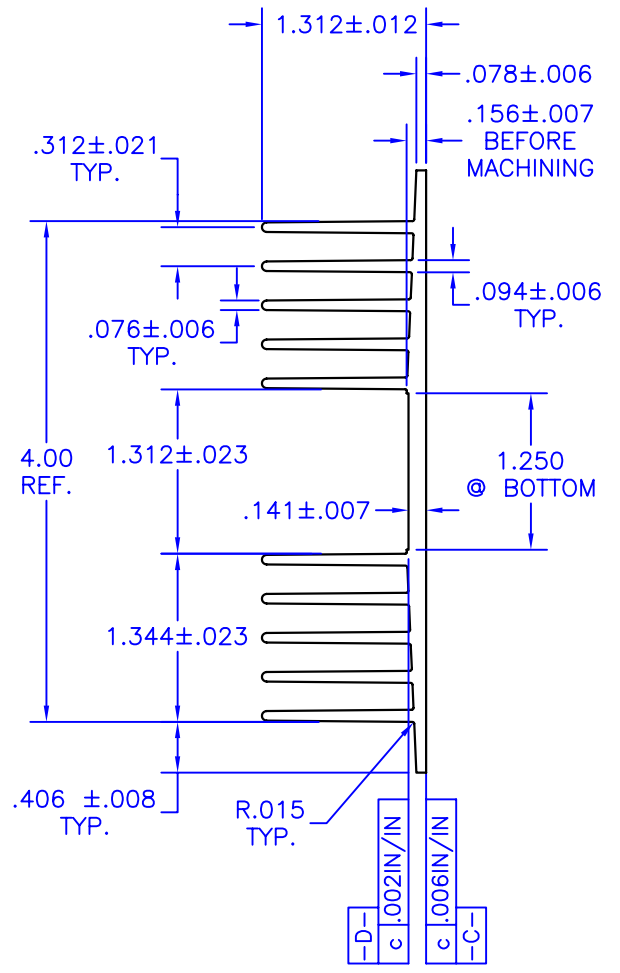
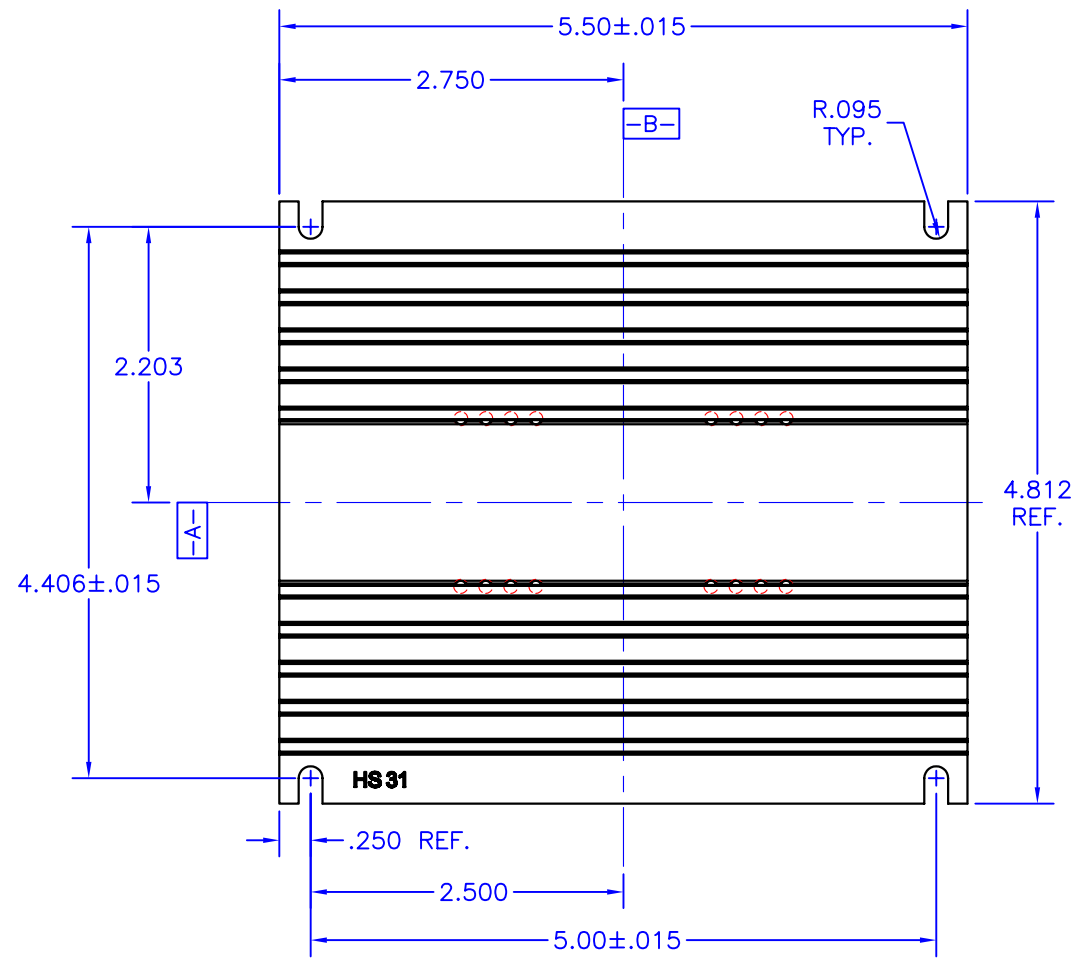

**P1 HEATSINK**  
 MAT'L: 6063-T5 ALUMINUM (AAVID EXTRUSION #60840)  
 FINISH: ANODIZE PER MIL-A-8625, TYPE II, CL 2, BLACK  
 TYPICAL BREAKDOWN VOLTAGE > 300V

- NOTES:**
- UNLESS OTHERWISE NOTED, ALL DIMENSIONS ARE IN INCHES.
  - BREAK ALL SHARP EDGES, DE-BURR & REMOVE LOOSE CHIPS.
  - MARK WITH CONTRASTING INK AS SHOWN, IF SPECIFIED BY PURCHASE ORDER.

TOLERANCES - UNLESS OTHERWISE SPECIFIED		TITLE		MODEL				
.XX = ±.01		OPEN FRAME PACKAGE HEATSINK		HS31				
.XXX = ±.005		SUBJECT		MECHANICAL DRAWING				
ANG. = ±.5°		END	TECH/INCL	DC#	SERIAL	DATE		
		D-M	D-M	44908	1 1	HS31-B	REV B	07/16/04

8 7 6 5 4 3 2 1