

		Revision	
Rev.	Description	Date	Approved

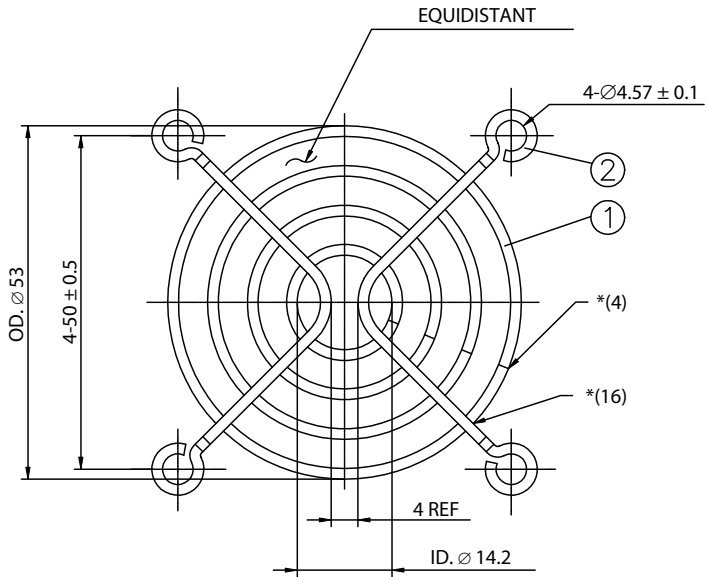

NOTE:

1. MATERIAL: SAE, 1008(OR EQUIVALENT).  
BRIGHT BASIC WIRE
2. FINISH: BRIGHT NICKEL-CHROME (TRIVALENT CHROME)  
PLATING
3. 0.30 ± 0.05 DEPTH OF SERRATIONS  
ON WIRE.
4. WELD JOINTS TO WITHSTAND 50 LBS.  
PULL FORCE.
5. RING: Ø1.6: RIB: Ø1.6
6. GENERAL TOLERANCE UNLESS  
NOTED IS ± 015\*\*\* & ± 030\*\*
7. UNIT: mm
8. RoHS COMPLIANT

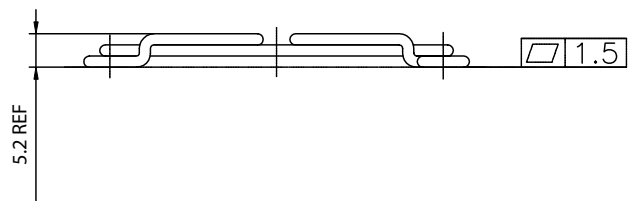

Dim range (mm)	Tolerance +/- (mm)	Qualtek Electronics Corp. FAN-S DIVISION		
		Part Number: 08147	RoHS Compliant	
0-1	0.15	Description: WIRE FORM FAN GUARD (60mm)		
1-6	0.20	UNIT: mm		
6-18	0.30	Rev B		
18-50	0.50	Drawn / Date	Checked / Date	Approved / Date
50-120	0.70	B. Grubb 08-18-06	08-18-06	JJH / 08-18-06
120-250	0.90			
250-500	1.20			