

FT170DC Series

Tubeaxial

19in.



- Fan Tray with brushless DC fans.
- Fans with electronically commutated external rotor motor.
- Fully integrated commutation electronics.
- Maintenance-free ball bearings.
- Fan tray made from painted cold rolled steel.
- Ready for insertion into cabinet or enclosure.
- Connecting leads with terminal strip.

Part Number	CFM @ 0	VDC	Volt. Range	Power (W)	dBA	Max Amb. Temp C	Bearing Type	Features	Wgt. (lbs)
FT-170-300-001	300	12	6 to 15	15.0	50	75	Ball	Terminal Block	3.00
FT-170-300-002	300	24	12 to 28	15.0	50	75	Ball	Terminal Block	3.00
FT-170-300-003	300	48	36 to 56	15.0	50	75	Ball	Terminal Block	3.00

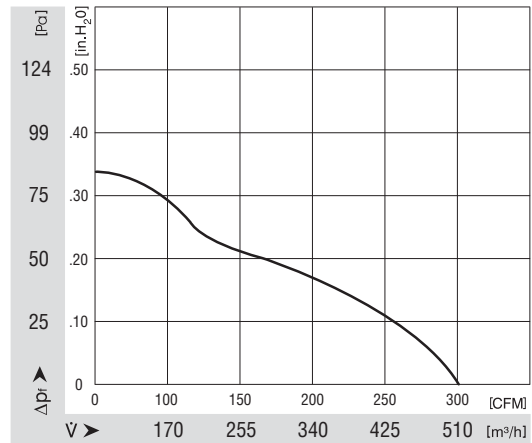
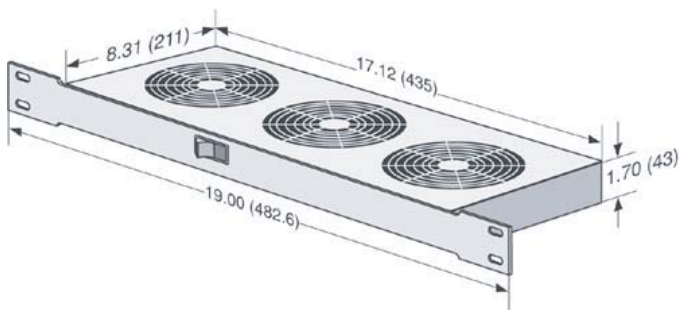

ebmpapst

e-mail: sales@us.ebmpapst.com · TEL: 860-674-1515 · FAX: 860-674-8536

ebm-papst Inc., 100 Hyde Road, Farmington, CT 06034 USA

ebm-papst Inc., 2006 © ebm-papst Inc. reserves the right to change any specifications or data without notice