



# SUNON

## SPECIFICATION FOR APPROVAL

**CUSTOMER** :

**DESCRIPTION** : AXIAL AC FAN

**DIMENSIONS** : 80X80X38 mm

**MODEL** : SF11580A

**P/N** : 1083HBL

**APPROVED NO** :

**APPROVED BY** :  
(AUTHORZIED)



DAWN.		CHKD.		APPD.		SPEC. NO.	283211300
						ISSUE DATE	09.20.1996
						EDITION	0
						REVISE DATE	
						E.SPEC	AC1083-SP02

**EME Fan & Motor**  
 13805 Alton Parkway, Suite B  
 Irvine, CA 92718  
 Telephone: (714) 583-0802 • Fax: (714) 583-0705

# AXIAL AC FAN

MODEL : SF11580A

P/N : 1083HBL



## CHARACTERISTICS

- 1. Motor Design : Reliable Shaded-Pole Motor Construction.
- 2. Insulation Resistance : 500 Megohms minimum at 500 VDC.
- 3. Dielectric Strength : 1500 VAC for one minute.
- 4. Motor Protection : Impedence protected.
- 5. Noise Level : Measured in an semi-anechoic chamber  
with background noise level below 15  
dBA. The fan is running in free air with  
microphone at a distance of one meter  
from the fan intake.
- 6. Air Performance : Measured by a double chamber. The value are  
recorded when the fan speed is stabilized at  
rated voltage.
- 7. Tolerances :  $\pm 15\%$  on rated power and current.



建準電機工業股份有限公司 SUNONWEALTH ELECTRIC MACHINE INDUSTRY CO., LTD.	SPEC. NO.	283211300	REVISE DATE	
	ISSUE DATE	09. 20. 1996	EDITION	0
	PAGE	2 OF 6		

## SPECIFICATIONS

MODEL: SF11580A

P/N : 1083HBL

- 1-1. Rated Voltage : 115/115 VAC 50/60 HZ
- 1-2. Operating Voltage Range : 85-125 VAC
- 1-3. Starting Voltage : 85 VAC
- 1-4. Rated Speed : 2400/2850 RPM±5%
- 1-5. Air Delivery : 24/31 CFM
- 1-6. Static Pressure : 0.13/0.19 Inch-H<sub>2</sub>O
- 1-7. Rated Current : 0.15/0.13 AMP
- 1-8. Input Power : 14/12 WATTS
- 1-9. Noise Level : 32/36.5 dB(A)
- 1-10. Direction of Rotation : Clockwies viewed from front face
- 1-11. Motor Protection : Impredance Protected
- 1-12. Operating Temperature : -10 to +70 Deg.C
- 1-13. Storage Temperature : -40 to +70 Deg.C
- 1-14. Bearing System : Precise ball bearing system
- 1-15. Weight : 340 g
- 1-16. Safety : UL/CSA Approvals



建準電機工業股份有限公司  
SUNONWEALTH ELECTRIC  
MACHINE INDUSTRY CO., LTD.

SPEC. NO.	283211300	REVISE DATE	
ISSUE DATE	09. 20. 1996	EDITION	0
PAGE	3 OF 6		

MODEL: SF11580A

P/N : 1083HBL



PERFORMANCE CURVES

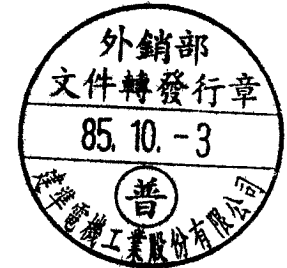

STATIC PRESSURE

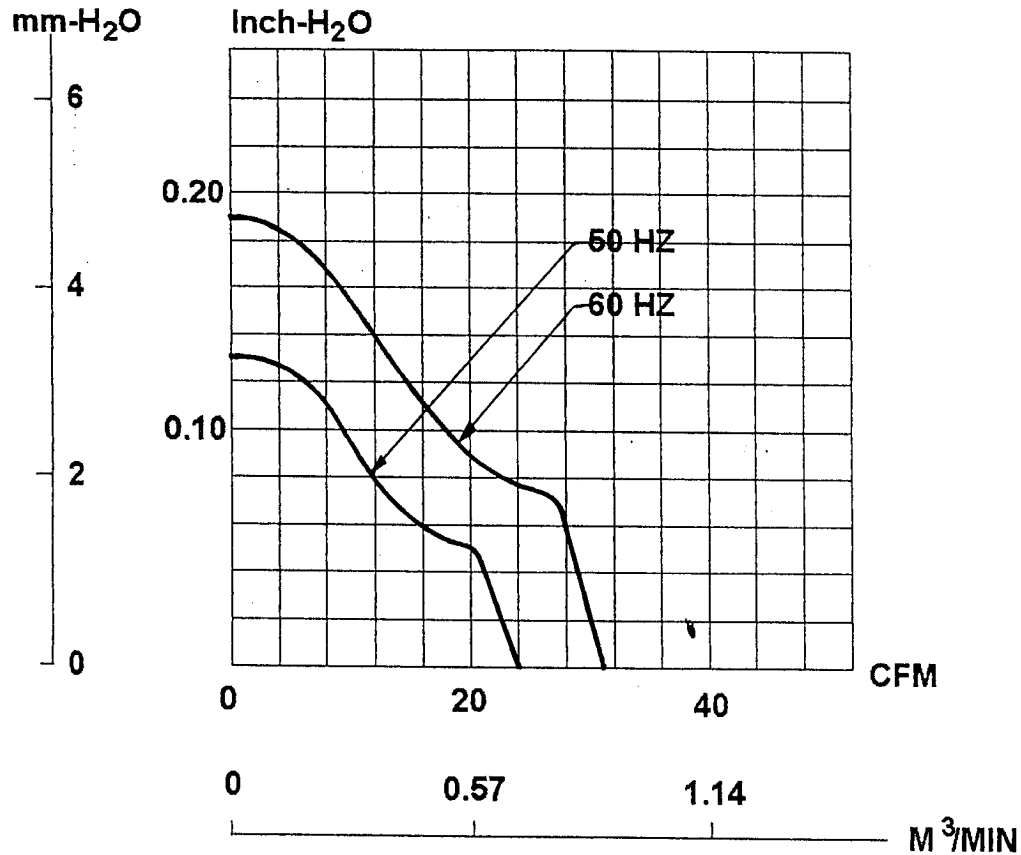

建準電機工業股份有限公司 SUNONWEALTH ELECTRIC MACHINE INDUSTRY CO., LTD.	SPEC. NO.	283211300	REVISE DATE	
	ISSUE DATE	09. 20. 1996	EDITION	0
	PAGE	4 OF 6		



**MATERIAL**

- 2. Material
- 2-1 Frame : Thermoplastic PBT of UL 94V-0
- 2-2. Impeller : Thermoplastic PBT of UL 94V-0
- 2-3. Lead Wire : UL1007,24AWG

**DIMENSIONS**

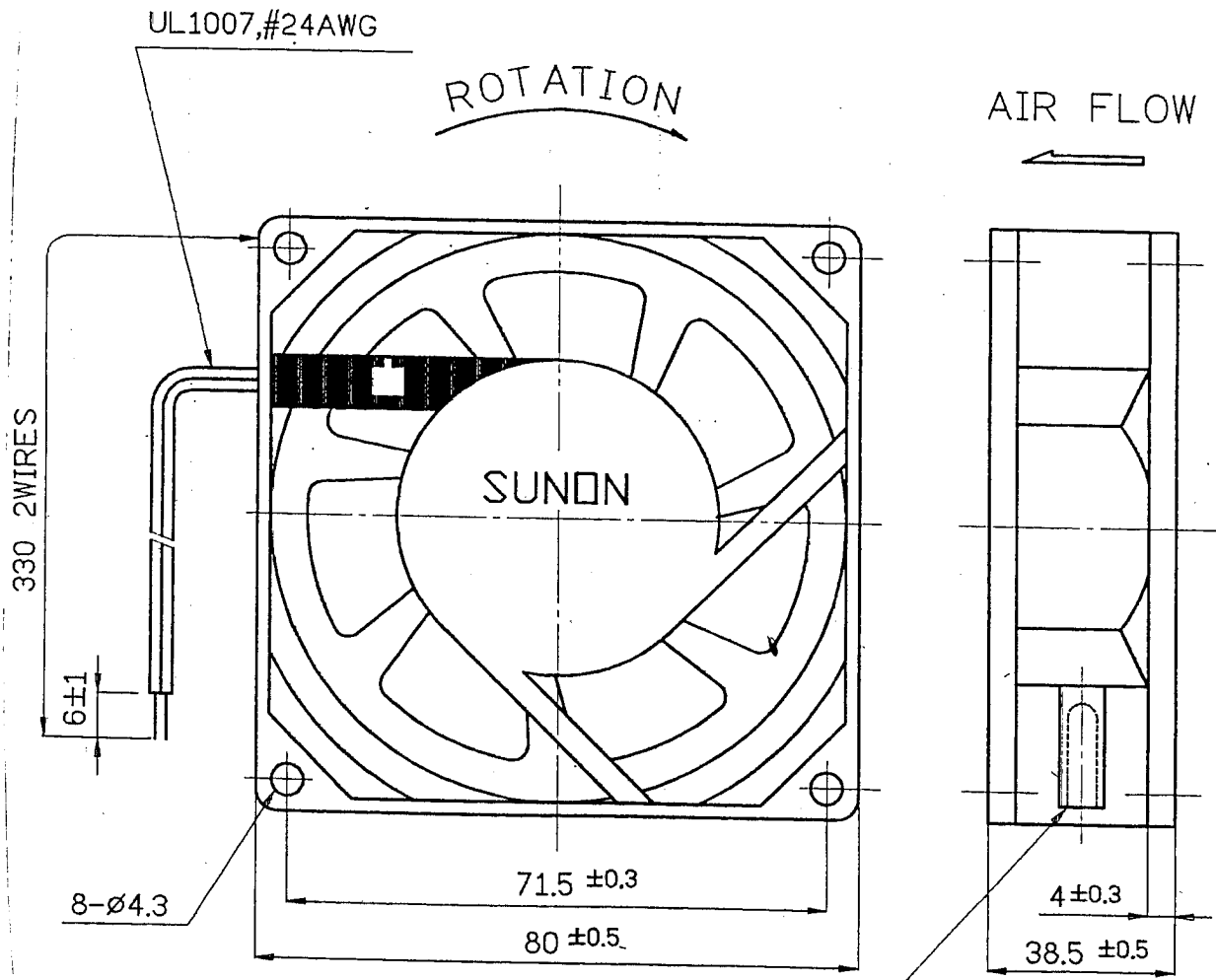

2 GROUND LUG

UNIT : mm

建準電機工業股份有限公司 SUNONWEALTH ELECTRIC MACHINE INDUSTRY CO., LTD.	SPEC. NO.	283211300	REVISE DATE	
	ISSUE DATE	09. 20. 1996	EDITION	0
	PAGE	5 OF 6		