

NHD-C12864WO-B1TMI#-M

COG (Chip-On-Glass) Liquid Crystal Display Module

NHD-	Newhaven Display
C12864-	128 x 64 pixels
WO-	Display Type: COG
B1-	Model
T-	White LED backlight
M-	STN- Blue (-)
I-	Transmissive, Wide Temp (-20°C ~ +70°C), 6:00 view
#-M-	Mounting holes
	RoHS Compliant

Newhaven Display International, Inc.

2511 Technology Drive, Suite 101

Elgin IL, 60124

Ph: 847-844-8795

Fax: 847-844-8796

www.newhavendisplay.com

nhtech@newhavendisplay.com

nhsales@newhavendisplay.com

Document Revision History

Revision	Date	Description	Changed by
0	9/1/2008	Initial Release	-
1	11/12/2009	User guide reformat	MC
2	12/14/2009	Updated Block Diagram	MC
3	1/12/2010	Added -M to p/n to signify this part has mounting holes	MC
4	3/9/2010	Block diagram updated	BE
5	5/4/2010	Block diagram and pin description	MP
6	5/5/2010	Backlight Connector updated	BE
7	5/14/2010	Pin description update	MP
8	5/2/2011	Example initialization code updated	AK
9	5/13/2011	Block diagram updated	AK
10	5/19/2011	Block diagram & Pin description updated	AK

Functions and Features

- 128 x 64 pixels
- Built-in ST7565P-G controller
- +3.3V power supply
- 1/65 duty cycle; 1/9 bias
- RoHS Compliant

Mechanical Drawing

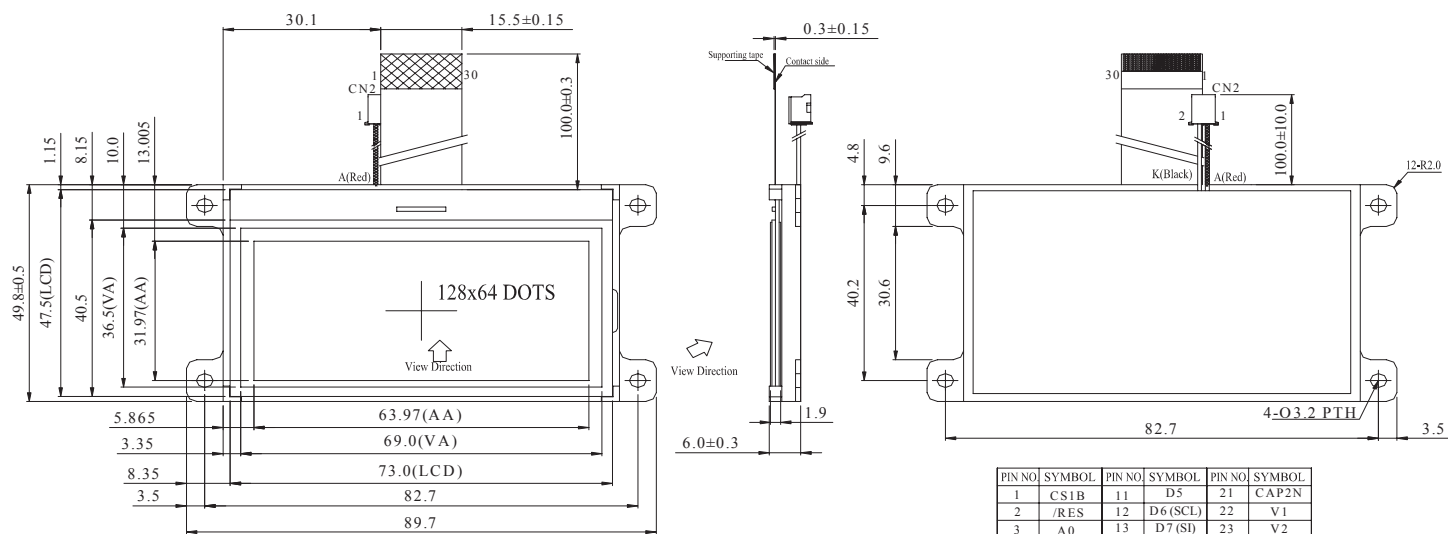

PIN NO	SYMBOL	PIN NO	SYMBOL	PIN NO	SYMBOL
1	CS1B	11	D5	21	CAP2N
2	/RES	12	D6(SCL)	22	V1
3	A0	13	D7(SI)	23	V2
4	/WR(R/W)	14	VDD	24	V3
5	/RD(E)	15	Vss	25	V4
6	D0	16	VOUT	26	V5
7	D1	17	CAP3P	27	VR
8	D2	18	CAP1N	28	C86
9	D3	19	CAP1P	29	P/S
10	D4	20	CAP2P	30	NC

The non-specified tolerance of dimension is ±0.2mm.

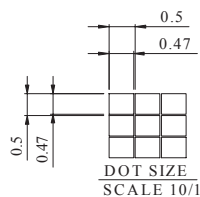
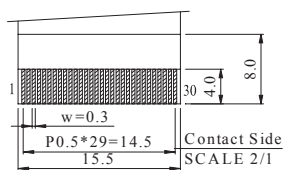

Newhaven Display
NHD-C12864WO-B1TMI#-M

Pin Description and Wiring Diagram

Pin No.	Symbol	External Connection	Function Description
1	/CS1 B	MPU	Active LOW chip select
2	/RES	MPU	Active LOW Reset signal
3	A0	MPU	Register select signal. 0: instruction; 1: data
4	/WR (R/W)	MPU	Read/write select signal. R/W=1: Read R/W=0: Write
5	/RD (E)	MPU	Operation enable signal. Falling edge triggered.
6-13	D0~D7	MPU	This is an 8-bit-directional data bus In serial mode D6= Serial data clock signal input D7= Serial data input
14	VDD	Power Supply	Power supply for logic (+3.3V)
15	VSS	Power Supply	Ground
16	VOUT	Power Supply	2.2uF cap to VSS
17	CAP3P	Power Supply	2.2uF cap to CAP1N (pin-18)
18	CAP1N	Power Supply	2.2uF cap to CAP3P (pin-17) and CAP1P (pin-19)
19	CAP1P	Power Supply	2.2uF cap to CAP1N (pin-18)
20	CAP2P	Power Supply	2.2uF cap to CAP2N (pin-21)
21	CAP2N	Power Supply	2.2uF cap to CAP2P (pin-20)
22	V1	Power Supply	2.2uF cap to VDD
23	V2	Power Supply	2.2uF cap to VDD
24	V3	Power Supply	2.2uF cap to VDD
25	V4	Power Supply	2.2uF cap to VDD
26	V5	Power Supply	2.2uF cap to VDD
27	VR	Adj Power Supply	Wiper of 10kΩ pot (see schematic below)
28	C86	MPU	Select MPU interface pin. C86= H:6800; C86= L:8080
29	P/S	MPU	Parallel/Serial select. PS= H: Parallel; PS= L: Serial
30	NC	-	No connect

Recommended LCD connector: 0.5mm Pitch, 30 pin FFC. Molex p/n: 52892-3095

Backlight connector: CJT p/n: A2001H **Mates with:** CJT A2001WR-S-2P

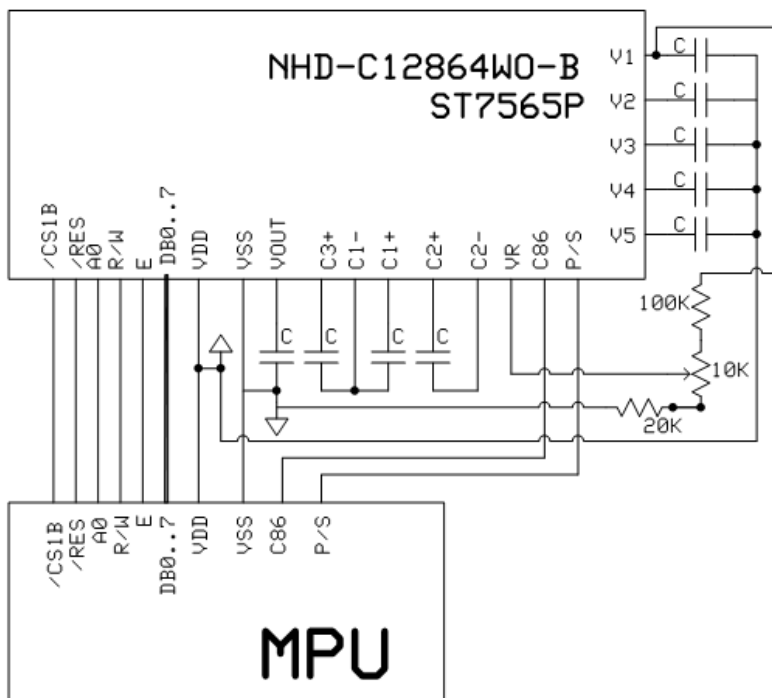

Electrical Characteristics

Item	Symbol	Condition	Min.	Typ.	Max.	Unit
Operating Temperature Range	TOP	Absolute Max	-20	-	+70	°C
Storage Temperature Range	TST	Absolute Max	-30	-	+80	°C
Supply Voltage	VDD		3.0	3.3	3.6	V
Supply Current	IDD	Ta=25°C, VDD=3.3V	-	0.6	2.0	mA
Supply for LCD (contrast)	VDD-V0	Ta=25°C	9.2	9.45	9.7	V
"H" Level input	Vih		0.8	-	VDD	V
"L" Level input	Vil		VSS	-	0.2VDD	V
"H" Level output	Voh		0.8	-	VDD	V
"L" Level output	Vol		VSS	-	0.2VDD	V
LED Backlight voltage	VLED		3.4	3.5	3.6	V
LED Backlight current	ILED	VLED=3.5V	61.2	72	100	mA
Backlight Lifetime		ILED=72mA		50,000		Hrs.

Optical Characteristics

Item	Symbol	Condition	Min.	Typ.	Max.	Unit
Viewing Angle - Vertical	K	CR ≥ 2	-20	-	+40	°
Viewing Angle - Horizontal	Φ	CR ≥ 2	-30	-	+30	°
Contrast Ratio	CR		-	3	-	-
Response Time (rise)	Tr		-	250	350	ms
Response Time (fall)	Tf		-	145	260	ms

Controller Information

Built-in ST7565P-G. Download specification at http://www.newhavendisplay.com/app_notes/ST7565.pdf

Timing Characteristics

System Bus Read/Write Characteristics 1 (For the 8080 Series MPU)

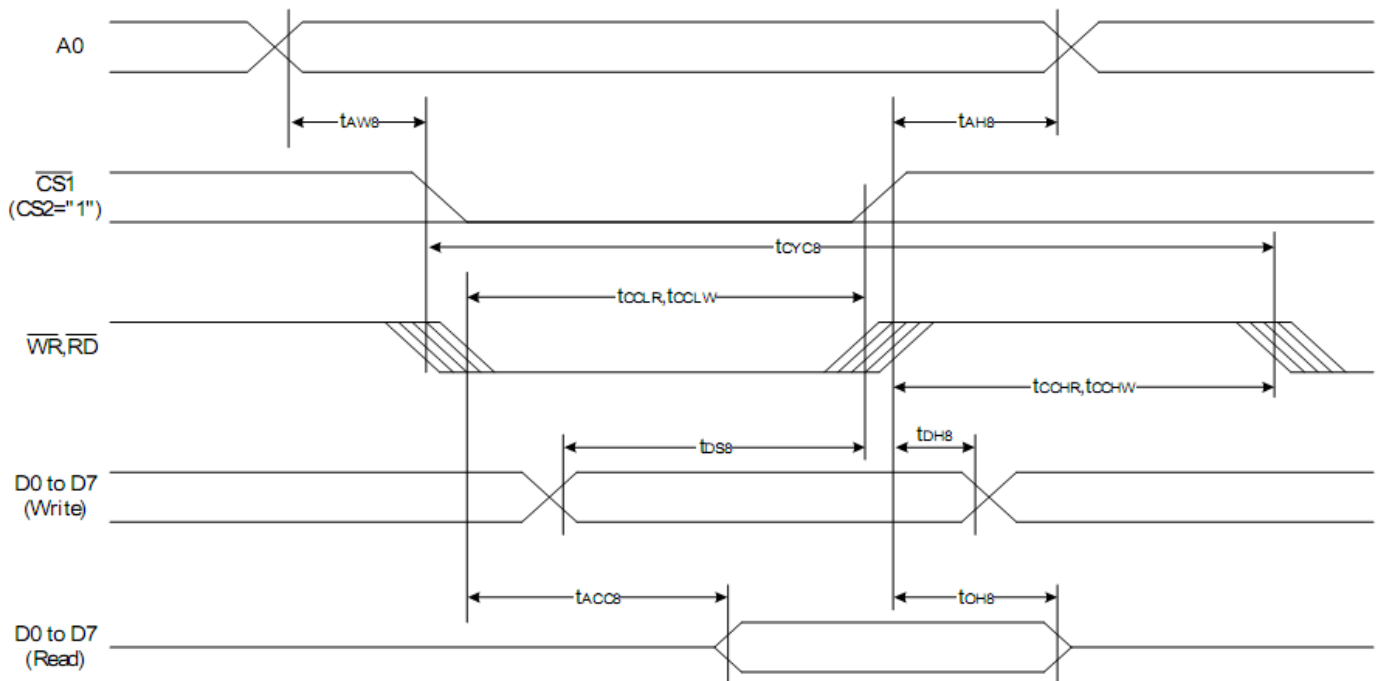

($V_{DD} = 4.5 \text{ V to } 5.5 \text{ V}$, $T_a = 25^\circ\text{C}$)

Item	Signal	Symbol	Condition	Rating		Units
				Min.	Max.	
Address hold time	A0	tAH8		0	—	ns
Address setup time		tAW8		0	—	
System cycle time		tCYC8		240	—	
Enable L pulse width (WRITE)	/WR	tOCLW		80	—	
Enable H pulse width (WRITE)		tOCHW		80	—	
Enable L pulse width (READ)	/RD	tOCLR		140	—	
Enable H pulse width (READ)		tOCHR		80	—	
WRITE Data setup time	D0 to D7	tDS8		40	—	
WRITE Address hold time		tDH8		0	—	
READ access time		tACC8	$C_L = 100 \text{ pF}$	—	70	
READ Output disable time		tOH8	$C_L = 100 \text{ pF}$	5	50	

*1 The input signal rise time and fall time (t_r , t_f) is specified at 15 ns or less. When the system cycle time is extremely fast, $(t_r + t_f) \leq (t_{CYC8} - t_{OCLW} - t_{OCHW})$ for $(t_r + t_f) \leq (t_{CYC8} - t_{OCLR} - t_{OCHR})$ are specified.

*2 All timing is specified using 20% and 80% of V_{DD} as the reference.

*3 tOCLW and tOCLR are specified as the overlap between /CS1 being "L" ($CS_2 = \text{"H"}$) and /WR and /RD being at the "L" level.

System Bus Read/Write Characteristics 2 (For the 6800 Series MPU)

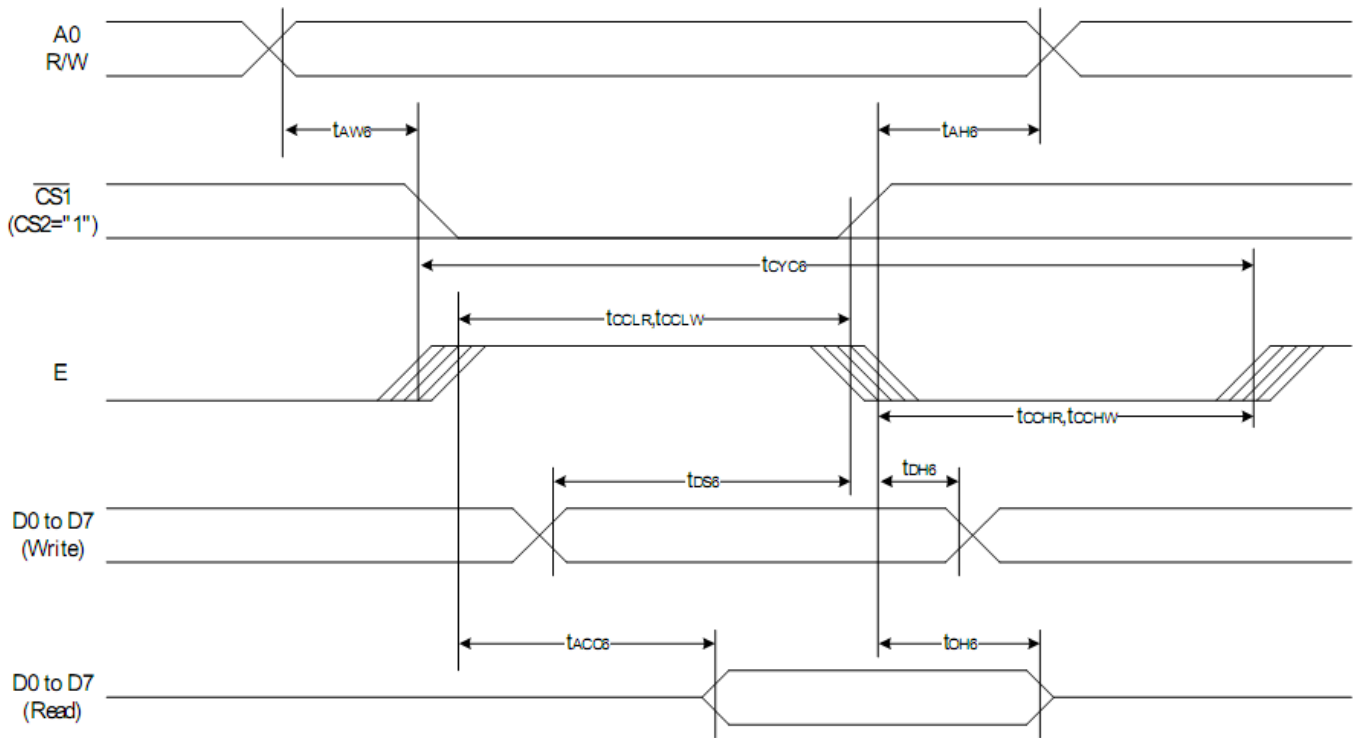

($V_{DD} = 4.5 \text{ V to } 5.5 \text{ V}$, $T_a = 25^\circ\text{C}$)

Item	Signal	Symbol	Condition	Rating		Units
				Min.	Max.	
Address hold time	A0	t_{AH6}		0	—	ns
Address setup time		t_{AW6}		0	—	
System cycle time		t_{CYC6}		240	—	
Enable L pulse width (WRITE)	/WR	t_{EWLW}		80	—	
Enable H pulse width (WRITE)		t_{EWHW}		80	—	
Enable L pulse width (READ)	/RD	t_{EWLR}		80	—	
Enable H pulse width (READ)		t_{EWHR}		140	—	
WRITE Data setup time	D0 to D7	t_{DS6}		40	—	
WRITE Address hold time		t_{DH6}		0	—	
READ access time		t_{ACC6}	$C_L = 100 \text{ pF}$	—	70	
READ Output disable time		t_{OH6}	$C_L = 100 \text{ pF}$	5	50	

Table of Commands

Table 16: Table of ST7565 Commands

Command	Command Code								Function			
	A0	/RD	/WR	D7	D6	D5	D4	D3		D2	D1	D0
(1) Display ON/OFF	0	1	0	1	0	1	0	1	1	1	0	1
(2) Display start line set	0	1	0	0	1	Display start address						
(3) Page address set	0	1	0	1	0	1	1	Page address				
(4) Column address set upper bit	0	1	0	0	0	0	1	Most significant column address				
Column address set lower bit	0	1	0	0	0	0	0	Least significant column address				
(5) Status read	0	0	1	Status				0	0	0	0	
(6) Display data write	1	1	0	Write data								
(7) Display data read	1	0	1	Read data								
(8) ADC select	0	1	0	1	0	1	0	0	0	0	0	1
(9) Display normal/reverse	0	1	0	1	0	1	0	0	1	1	0	1
(10) Display all points ON/OFF	0	1	0	1	0	1	0	0	1	0	0	1
(11) LCD bias set	0	1	0	1	0	1	0	0	0	1	0	1
(12) Read/modify/write	0	1	0	1	1	1	0	0	0	0	0	0
(13) End	0	1	0	1	1	1	0	1	1	1	0	
(14) Reset	0	1	0	1	1	1	0	0	0	1	0	
(15) Common output mode select	0	1	0	1	1	0	0	0	*	*	*	1
(16) Power control set	0	1	0	0	0	1	0	1	Operating mode			
(17) V5 voltage regulator internal resistor ratio set	0	1	0	0	0	1	0	0	Resistor ratio			
(18) Electronic volume mode set	0	1	0	1	0	0	0	0	0	0	0	1
Electronic volume register set				0	0	Electronic volume value						
(19) Static indicator ON/OFF	0	1	0	1	0	1	0	1	1	0	0	1
Static indicator register set				0	0	0	0	0	0	0	Mode	
(20) Power saver												
(21) NOP	0	1	0	1	1	1	0	0	0	1	1	
(22) Test	0	1	0	1	1	1	1	*	*	*	*	

(Note) *: disabled data

Example Initialization Program

```
/******
```

```
void comm_out(unsigned int c)
```

```
{
```

```
    CS1 = 0; //Active Low
```

```
    AO = 0; //LOW = instruction
```

```
    delay(1);
```

```
    WRT = 0; // /WR in 8080 mode; R/W in 6800 mode
```

```
    P1 = c;
```

```
    delay(1);
```

```
    WRT = 1; // /WR in 8080 mode; R/W in 6800 mode
```

```
    CS1 = 1; //inactive
```

```
}
```

```
void data_out(unsigned int d)
```

```
{
```

```
    CS1 = 0; //Active Low
```

```
    AO = 1; //High = Data
```

```
    delay(1);
```

```
    WRT = 0;
```

```
    P1 = d;
```

```
    delay(1);
```

```
    WRT = 1;
```

```
    CS1 = 1; //inactive
```

```
}
```

```
void init()
```

```
{
```

```
    //IRS pin is tied low internally - external resistor circuit must be used
```

```
    C86 = 1;        // Interface set to 8080 mode
```

```

RDD = 1;      // /RD in 8080 mode; E in 6800 mode

WRT = 1;      // /WR in 8080 mode; R/W in 6800 mode

CS1 = 0;

RST = 1;      // /RST in 8080 mode; /RES in 6800 mode

RST = 0;      // /RST in 8080 mode; /RES in 6800 mode

delay(2);

RST = 1;      // /RST in 8080 mode; /RES in 6800 mode

delay(2);

comm_out(0xA2); //added 1/9 bias

comm_out(0xA0); //ADC segment driver direction (A0=Normal)

comm_out(0xC8);

comm_out(0xC0); //COM output scan direction (C0= Normal)

comm_out(0x40); //Operating Mode

delay(0);

comm_out(0x25); //resistor ratio

delay(0);

comm_out(0x19); //column address set upper bit

delay(0);

comm_out(0x2F); //select internal resistor ratio

delay(0);

comm_out(0xAF); //display ON/OFF - set to ON

}

/*****/

```

Quality Information

Test Item	Content of Test	Test Condition	Note
High Temperature storage	Endurance test applying the high storage temperature for a long time.	+80°C , 200hrs	2
Low Temperature storage	Endurance test applying the low storage temperature for a long time.	-30°C , 200hrs	1,2
High Temperature Operation	Endurance test applying the electric stress (voltage & current) and the high thermal stress for a long time.	+70°C 200hrs	2
Low Temperature Operation	Endurance test applying the electric stress (voltage & current) and the low thermal stress for a long time.	-20°C , 200hrs	1,2
High Temperature / Humidity Operation	Endurance test applying the electric stress (voltage & current) and the high thermal with high humidity stress for a long time.	+60°C , 90% RH , 96hrs	1,2
Thermal Shock resistance	Endurance test applying the electric stress (voltage & current) during a cycle of low and high thermal stress.	-20°C,30min -> 25°C,5min -> 70°C,30min = 1 cycle 10 cycles	
Vibration test	Endurance test applying vibration to simulate transportation and use.	10-55Hz , 15mm amplitude. 60 sec in each of 3 directions X,Y,Z For 15 minutes	3
Static electricity test	Endurance test applying electric static discharge.	VS=800V, RS=1.5kΩ, CS=100pF One time	

Note 1: No condensation to be observed.

Note 2: Conducted after 4 hours of storage at 25°C, 0%RH.

Note 3: Test performed on product itself, not inside a container.

Precautions for using LCDs/LCMs

See Precautions at www.newhavendisplay.com/specs/precautions.pdf

Warranty Information and Terms & Conditions

http://www.newhavendisplay.com/index.php?main_page=terms